



## **KERALA RURAL WATER SUPPLY AND SANITATION AGENCY**

**Name of Work : Providing additional well, tank and Maintenance  
works to Pulvetta WSS in Karuvarakundu GP, Malappuram  
District.**

**E-TENDER No : 04/SUS/KRWSA/RPMU/MPM/KAR/2022**

**DUE DATE & TIME FOR  
UPLOADING OF TENDER BY TENDERER : 03/12/2022, 03.00 PM**

**TENDER OPENING DATE : 05/12/2022, 11.00 AM**

## **NOTICE INVITING TENDER**

### **VOLUME – I & II**

**OFFICE OF THE REGIONAL PROJECT DIRECTOR**

**KERALA RURAL WATER SUPPLY AND SANITATION AGENCY**

**RPMU MALAPPURAM**

**KERALA STATE**

**TELEPHONE: 0483 2738566**

**Email ID : [rpmumalappuram1@gmail.com](mailto:rpmumalappuram1@gmail.com)**

## CONTENTS

Sl. No.	Description	Page No.
a	Check list of Bidder submittals	a
b	General Tender Terms & Conditions for Kerala State E-Procurement System	b-e
	<b>Volume I</b>	f
1.	E -Tender Notice	1-2
2.	Detailed Tender Notice	3-4
3.	Letter Submitting the Tender	5-6
4.	Particulars showing the status of tenderer	7
5.	Forms of Agreement	8-10
6.	Definitions and Interpretations	11-12
7.	Tender Conditions - Part: I - Qualification of Tenderers	13-20
8.	Tender Conditions - Part: II	21-30
9.	Tender Conditions - Part: III – Contract Conditions	32-44
10.	General Technical Specifications	45-57
	<b>Volume II (Scope of Work)</b>	<b>58</b>
	<b><u>Other Appendix &amp; Annexures</u></b>	63 onwards

## Check list of Bidder submittals

<b>Sl. No.</b>	<b>Documents / Particulars</b>	<b>Page No.</b>	<b>Put mark</b>
1	Letter submitting tender along with check list		
2	Particulars Showing Status of Tenderer		
3	Preliminary agreement		
4	Partnership / Joint Venture details of bidders as per 7.4.1		
5	Form of Declaration of non relationship (Annexure I)		
6	Undertaking regarding delayed works in KRWSA/Non Blacklisted		
7	Signed copy of NIT Vol I & II along with attachments		
8	Contract License		
9	PAN Card		
10	GST registration		
11	Bidder's Bank Account details		
12	Copy of Adhar Card		

**Signature of the Contractor**

(a)



**KERALA RURAL WATER SUPPLY AND SANITATION AGENCY**  
**General Tender Terms & Conditions for Kerala State e-Procurement System**  
**through <https://www.etenders.kerala.gov.in>**

**(The clauses, sentences, words etc. stricken off shall be treated not applicable to this tender)**

This tender is an e-Tender and is being published online for the work/supply: “Providing additional well, tank and Maintenance works to Pulvetta WSS in Karuvarakundu GP, Malappuram District”. The tender is invited in ~~ONE/TWO~~ (strike off whichever is not applicable) cover system from the registered and eligible firms through e-procurement portal of Government of Kerala (<https://www.etenders.kerala.gov.in>). Prospective bidders willing to participate in this tender shall necessarily register themselves with above mentioned e-procurement portal.

The tender timeline is available in the critical date section of this tender published in [www.etenders.kerala.gov.in](http://www.etenders.kerala.gov.in).

**A). Online Bidder registration process:**

Bidders should have a Class II or above Digital Signature Certificate (DSC) to be procured from any Registration Authorities (RA) under the Certifying Agency of India. Details of RAs will be available on [www.cca.gov.in](http://www.cca.gov.in). Once, the DSC is obtained, bidders have to register on [www.etenders.kerala.gov.in](http://www.etenders.kerala.gov.in) website for participating in this tender. Website registration is a one-time process without any registration fees. However, bidders have to procure DSC at their own cost.

Bidders may contact e-Procurement support desk of Kerala State IT Mission over telephone at 0471-2577088/188/388 or 0484-2336006, 2332262 or 0497-2764788, 2764188 or 0483-273294 or through email: [etendershelp@kerala.gov.in](mailto:etendershelp@kerala.gov.in) or [helpetender@gmail.com](mailto:helpetender@gmail.com) for assistance in this regard.

**B). Online Tender Process:**

The tender process shall consist of the following stages:

i. **Downloading of tender document:** Tender document will be available for free download on [www.etenders.kerala.gov.in](http://www.etenders.kerala.gov.in). However, tender document fees shall be payable at the time of bid submission as stipulated in this tender document.

ii. **Pre-bid meeting:** As mentioned in the tender documents.

iii. **Publishing of Corrigendum:** All corrigenda shall be published on [www.etenders.kerala.gov.in](http://www.etenders.kerala.gov.in) and shall not be available elsewhere.

iv. **Bid submission:** Bidders have to submit their bids along with supporting documents to support their eligibility, as required in this tender document on [www.etenders.kerala.gov.in](http://www.etenders.kerala.gov.in)

v. **Opening of Technical Bid and Bidder short-listing:** The technical bids will be opened, evaluated and shortlisted as per the eligibility and technical qualifications. All documents in support of technical qualifications shall be submitted (online). Failure to submit the documents online will attract disqualification. Bids shortlisted by this process will be taken up for opening the financial bid.

(b)

vi. **Opening of Financial Bids:** Bids of the qualified bidder's shall only be considered for opening and evaluation of the financial bid on the date and time mentioned in critical date's section.

**C. Documents Comprising Bid:**

**(i). The First Stage (Pre-Qualification or Technical Cover based on 1 cover or 2 cover tender system):**

Pre-Qualification or Technical proposal shall contain the scanned copies of the following documents which every bidder has to upload:

- i. Document 1 : Scanned copy of duly filled and signed preliminary agreement prepared in Kerala Stamp Paper worth Rs.200/-
- ii. Document 2 : Scanned copy of documents to prove eligibility criteria
- iii. Document 3: The NIT documents of the work downloaded from the website to agree with the tender conditions
- iv. Documents : Any other documents as per the requirement of the tender conditions

**(ii). The Second Stage (Financial Cover or as per tender cover system):**

v. The Bidder shall complete the Price bid as per format given for download along with this tender.

Kerala Rural Water Supply And Sanitation Agency doesn't take any responsibility for any technical snag or failure that has taken place during document upload.

**Note:** The blank price bid should be downloaded and saved on bidder's computer without changing file-name otherwise price bid will not get uploaded. The bidder should fill in the details in the same file and upload the same back to the website.

**Fixed price:** Prices quoted by the Bidder shall be fixed during the bidder's performance of the contract and not subject to variation on any account. A bid submitted with an adjustable/ variable price quotation will be treated as non - responsive and rejected.

**D). Tender Fee and Earnest Money Deposit (EMD)**

The Bidder shall pay, a tender fee and Earnest Money Deposit (EMD) or Bid Security amount as per the tender documents. The Bid security is required to protect the purchaser against risk of Bidder's conduct, which would warrant the forfeiture of security.

**Online Payment modes:** The tender fee and EMD can be paid in the following manner through e-Payment facility provided by the e-Procurement system:

**State Bank of India Multi Option Payment System (SBI MOPS Gateway):**

Bidders are required to avail Internet Banking Facility in any of below banks for making tender remittances in e Procurement System.

1	Allahabad Bank	32	Kotak Mahindra Bank
2	Axis Bank	33	Lakshmi Vilas Bank
3	Andhra Bank	34	Mehsana Urban Co-op Bank
4	Bandan Bank	35	NKGSB Co-operative Bank
5	Bank of Bahrain and Kuwait	36	Oriental Bank of Commerce
6	Bank of Baroda	37	Punjab and Maharashtra Cooperative Bank
7	Bank of India	38	Punjab National Bank
8	Bank of Maharashtra	39	Punjab and Sind Bank

(c)

9	Bassein Catholic Co-operative Bank	40	RBL Bank
10	BNP Paribas	41	Saraswat Cooperative Bank
11	Canara Bank	42	ShamraoVithal Cooperative Bank
12	Catholic Syrian Bank	43	South Indian Bank
13	Central Bank of India	44	Standard Chartered Bank
14	City Union Bank	45	State Bank of India
15	Corporation Bank	46	Syndicate Bank
16	Cosmos Bank	47	Tamilnad Mercantile Bank
17	DCB Bank	48	Tamilnadu Cooperative Bank
18	Dena Bank	49	The Kalyan Janata Sahakari Bank
19	Deutsche Bank	50	TJSB Bank (Erstwhile Thane Janata Sahakari Bank)
20	Dhanalaxmi Bank	51	UCO Bank
21	Federal Bank	52	Union Bank of India
22	HDFC Bank	53	United Bank of India
23	ICICI Bank	54	Vijaya Bank
24	IDBI Bank	55	YES Bank
25	Indian Bank		
26	Indian Overseas Bank		
27	IndusInd Bank		
28	Jammu & Kashmir Bank		
29	Janata Sahakari Bank		
30	Karnataka Bank		
31	Karur Vysya Bank		
<b>B) Internet Banking Options (Corporate)</b>			
1	Bank of Baroda	21	Laxmi Vilas Bank
2	Bank of India	22	Oriental Bank of Commerce
3	Bank of Maharashtra	23	Punjab & Maharashtra Coop Bank
4	BNP Paribas	24	Punjab & Sind Bank
5	Canara Bank	25	Punjab National Bank
6	Catholic Syrian Bank	26	RBL Bank
7	City Union Bank	27	ShamraoVithal Co-operative Bank
8	Corporation Bank	28	South Indian Bank
9	Cosmos Bank	29	State Bank of India
10	Deutsche Bank	30	Syndicate Bank
11	Development Credit Bank	31	UCO Bank
12	Dhanalaxmi Bank	32	Union Bank of India
13	Federal Bank	33	UPPCL
14	HDFC Bank	34	Vijaya Bank
15	ICICI Bank	35	Axis Bank
16	Indian Overseas Bank		
17	Janta Sahakari Bank		
18	Jammu & Kashmir Bank		
19	Karur Vysya Bank		
20	Kotak Bank		

During the online bid submission process, bidder shall select **SBI MOPS** option and submit the page, to view the **Terms and Conditions** page. On further submitting the same, the e-Procurement system will redirect the bidder to MOPS Gateway, where two options namely **SBI** and **Other Banks\*** will be shown. Here, Bidder may proceed as per below:

(d)

- a. *SBI Account Holders* shall click **SBI** option with its Net Banking Facility., where bidder can enter their internet banking credentials and transfer the Tender Fee and EMD amount.
- b. *Other Bank Account Holders* may click **Other Banks** option to view the bank selection page. Here, bidders can select from any of the 54 Banks to proceed with its Net Banking Facility, for remitting tender payments.

*\*Transaction Charges for Other Banks vide SBI Letter No. LHO/TVM/AC/2016-17/47 – 1% of transaction value subject to a minimum of Rs. 50/- and maximum of Rs. 150/-.*

Any transaction charges levied while using any of the above modes of online payment has be borne by the bidder. The supplier/contractor's bid will be evaluated only if payment status against bidder is showing “Success” during bid opening

#### **E). SUBMISSION PROCESS**

For submission of bids, all interested bidders have to register online as explained above in this document. After registration, bidders shall submit their Technical bid and Financial bid online on [www.etenders.kerala.gov.in](http://www.etenders.kerala.gov.in) along with online payment of tender fee and EMD.

For page by page instructions on bid submission process, please visit [www.etenders.kerala.gov.in](http://www.etenders.kerala.gov.in) and click “Bidders Manual Kit” link on the home page.

**It is necessary to click on “Freeze bid” link/ icon to complete the process of bid submission otherwise the bid will not get submitted online and the same shall not be available for viewing/ opening during bid opening process.**

The bidders have the opportunity to revise the rates or documents uploaded by him even after submission, till the closing date of the tender. Also the bidder can withdraw his offer before the closing date. Resubmission will not be possible for withdrawn bids. The option is available from "my active bids" link.

(e)



## **KERALA RURAL WATER SUPPLY AND SANITATION AGENCY**

**Name of Work : Providing additional well, tank and  
Maintenance works to Pulvetta WSS in Karuvarakundu GP,  
Malappuram District**

**E-TENDER No : 04/SUS/KRWSA/RPMU/MPM/KAR/2022**

**DUE DATE & TIME FOR  
UPLOADING OF TENDER BY TENDERER : 03/12/2022, 03.00 PM**

**TENDER OPENING DATE : 05/12/2022, 11.00 AM**

## **NOTICE INVITING TENDER**

### **VOLUME – I**

**OFFICE OF THE REGIONAL PROJECT DIRECTOR  
KERALA RURAL WATER SUPPLY AND SANITATION AGENCY**

**RPMU MALAPPURAM**

**KERALA STATE**

**TELEPHONE: 0483 2738566**

**Email ID : [rpmumalappuram1@gmail.com](mailto:rpmumalappuram1@gmail.com)**

(f)



## 1. E-TENDER NOTICE

The Regional Project Director, Kerala Rural Water Supply and Sanitation Agency, Malappuram invites sealed competitive electronic tenders in ~~ONE/TWO~~ level system for the following work on ~~Percentage/Item rate/Lump sum/EPCM~~ basis from Registered Class A/Class B/Class C contractors of Kerala Water Authority or contractors Registered in other departments in Kerala State / in other states in India/ in equivalent class and manufacturers eligible for A/B/C class license from Kerala Water Authority/PWD/CPWD/reputed contracting firms in India. The tenderers shall have experience in implementing similar works.

The tender is invited in Single Cover/~~Double cover~~ system from the registered and eligible firms through e-procurement portal of Government of Kerala (<https://www.etenders.kerala.gov.in>). Prospective bidders willing to participate in this tender shall necessarily register themselves with above mentioned e-procurement portal.

The tender timeline is available in the critical date section of this tender published in [www.etenders.kerala.gov.in](http://www.etenders.kerala.gov.in).

The brief details of tender are as follows :

E Tender No.	04/SUS/ KRWSA/RPMU/MPM/KAR/2022
Name of Project	Sustainability 2021-22
Name of work	Providing additional well, tank and Maintenance works to Pulvetta WSS in Karuvarakundu GP, Malappuram District
Nature of works	Civil
Location	Karuvarakundu Grama Panchayath, Malappuram District
Probable Amount of Contract	Rs. 30,03,837/- (Tendered PAC)
Period of Completion	<b>3 months</b> from date of Award of work
Source of Fund for this work	KRWSA - Sustainability 2020-21
Sale of Tender Documents	Documents are available in the site <a href="http://www.etenders.kerala.gov.in">www.etenders.kerala.gov.in</a> for free download
Tender forms received by	The Regional Project Director, Kerala Rural Water Supply and Sanitation Agency, RPMU Malappuram
Tender fee	Rs. 2,500/- + 18% GST (GST will be paid by the contractor on reverse charge basis while filing his returns).
EMD	Rs. 50,000/- (Rupees Fifty Thousand only)
Mode of payment (Tender fee & EMD)	Online payment

<del>Pre bid meeting</del>	
Clarification regarding bid	All clarifications sought up to 30.11.2022 at 5.00 PM via E mail will be answered
Corrigendum	Corrigendum if any will be published in web site
Last date and time of submission of tenders electronically to the tendering Authority	03.12.2022 at 3.00 PM
Date and time of opening of tenders	05.12.2022 at 11.00 AM
Validity of Bid (Firm period)	120 days from the last date of submission of bid (electronically)
Place of execution of agreement	Office of the Regional Project Director, Kerala Rural Water Supply and Sanitation Agency, RPMU Malappuram

Interested bidders can get further details regarding the work from the office of the Regional Project Director, Kerala Rural Water Supply and Sanitation Agency, MMC.X/108-112, 2<sup>nd</sup> Floor, UMK Tower, Jubilee road, Uphill, Malappuram – 676505 (Phone : 0483 - 2738566, Email ID : rpmumalappuram1@gmail.com).

All other relevant rules followed by KRWSA shall be applicable.

Sd/-  
The Regional Project Director  
RPMU Malappuram, KRWSA

# KERALA RURAL WATER SUPPLY AND SANITATION AGENCY

## 2. DETAILED TENDER NOTICE

1. Sealed competitive tenders are invited for and on behalf of Executive Director, Kerala Rural Water Supply And Sanitation Agency, by the undersigned, from Registered Class A/Class B/Class C Contractors of Kerala Water Authority/Contractors Registered in Other Departments in Kerala State or other States in India equivalent class and also Manufacturers/ reputed contracting firms in India, eligible for A/B/C Class license from Kerala Water Authority/PWD/CPWD/reputed contracting firms in India, with experience in Surveying, Designing, Supplying, Laying, testing, Trial running and Commissioning of FHTCs, pipe lines/ tanks/ WTP etc whichever is necessary as per the scope of work in volume II of NIT for the following works.

*Name of project* : Sustainability 2021-22

*Name of work* : Providing additional well, tank and Maintenance works to Pulvetta WSS in Karuvarakundu GP, Malappuram District

2. Intending tenderers may enroll themselves for e-tendering in the website [www.etenders.kerala.gov.in](http://www.etenders.kerala.gov.in). One time registration is valid for all KRWSA tenders. The contractors who are registered for e-tendering and have valid password can only view / download the Tender Documents. The Tender Schedule shall be filled up in the prescribed format provided in tender document. For uploading the tender documents, the tenderer has to remit the amount towards cost of tender documents as well as the prescribed EMD through online payment mechanism for e-procurement system of Govt. of Kerala. Tenderers are advised to visit the "Downloads" section of e-Procurement website ([www.etenders.kerala.gov.in](http://www.etenders.kerala.gov.in)) for detailed instructions on making online payment using **internet banking facility only**. Only those tender schedules which are downloaded from the website and uploaded after filling only will be considered. Bidders can make use of the links "help for Contractors", "FAQ", "Bidders Manual Kit" etc. in the above website for more details on registration and bid submission. For further assistance they can also contact over phone or by mail to the regional offices of Kerala State IT Mission in the addresses available in the website.

The tenders shall be submitted electronically to The Regional Project Director, Kerala Rural Water Supply and Sanitation Agency, RPMU Malappuram in the method available at the web site [www.etenders.kerala.gov.in](http://www.etenders.kerala.gov.in). The tenderer has to remit the amount towards cost of tender documents and EMD through online payment in time. The bid submission is allowed up to the last date and time given in this tender notice. Submitting bid documents in no way for a right or / eligibility for qualification of awarding the work. The qualification criteria are described in the bid document.

The bidder shall fill up the prefixed formats and price bids along with NIT, Scope of work or any other document uploaded by the Regional Project Director and upload in the website. Additional documents if any are to be scanned and uploaded in the website. The price bid shall be submitted electronically only. The tenderer shall produce before the Regional project Director, the originals of the documents uploaded including those scanned and uploaded (except price bid) with the preliminary agreement executed in the prescribed Kerala Stamp paper (Rs.200/-).

Technical Bid shall be opened in the presence of the Bidder or their authorized representative who chooses to attend the specified tender opening. After the evaluation of Technical Bid, the Regional Project Director will intimate the bidders who have qualified in Technical bid, the date and time of opening of the Price bid which will be fixed subsequently. The participating bidders can view the bid opening online and

view the rates of competitors after tender opening. Bidders are requested to furnish Telephone No/Fax No/Email ID for speedy transfer of information.

The Regional Project Director will not be responsible for any cost or expenses incurred by bidders in connection with preparation or delivery of bid or loss of any document during transit. Date extension will not be allowed without specific reasons and which is beyond the control of KRWSA. In the event of any of the specified date being declared a holiday, the event will take place at the same time and place on the next working day. All other conditions of invitation of tenders will be as per prevalent rules in Kerala Rural water Supply and Sanitation Agency.

- ~~3. A pre bid meeting will be convened by the Regional Project Director at Regional Project Management Unit, Malappuram office on ..... to clarify any issues raised by the intending tenderers in advance. The minutes of such pre bid meeting shall also form part of this tender document and a copy of the same duly signed by the Tenderer /firm shall be enclosed with the tender submitted.~~
4. Period of completion of the work tendered will be 3 (Three) months.
5. The tenders shall be submitted electronically before 03.00 PM on 03/12/2022. The bidder shall fill up the details and price bids in prefixed formats along with NIT, Scope of work or any other document uploaded by the Office of the Regional Project Director, KRWSA, RPMU Malappuram and upload in the website. Additional documents if any are to be scanned and uploaded in the website. The price bids in prescribed should be submitted electronically only. **The covering letter submitting the tender shall be in the form given in Chapter 3.**
6. The tenders shall be opened at 11.00 AM on 05/12/2022. The bidders are advised to be present for the opening of tender or they can view the opening through the web site. The electronically submitted price bid of those contractors whose technical bids are at par with the N.I.T only will be opened by the Office of the Regional Project Director, KRWSA, RPMU Malappuram after giving due information about the time and date to all the selected bidders in advance and in the presence of the bidders present at the time of opening. The decision of the Regional Project Director, KRWSA, RPMU Malappuram, regarding the eligibility to be selected for the opening of the financial bids will be final and it shall not be appealable. Tenders without requisite EMD and other particulars shall not be considered further but will be retained with KRWSA.
7. The cost of tender form, for this tender is not refundable even though the tender is cancelled or rejected at any stage.
8. The contractors who are black listed by competent authority or lagged two or more works of KRWSA shall not be eligible to participate in this tender.

Sd/-  
The Regional Project Director  
RPMU Malappuram, KRWSA

### 3. LETTER SUBMITTING THE TENDER

Ref. No. :

Place :

Date :

From

To

The Regional Project Director  
Kerala rural water Supply and Sanitation Agency  
Regional Project Management Unit, Malappuram  
MMC.X/108-112, UMK Tower, Uphill  
Jubilee road, Near passport office  
Malappuram P.O. – 676 505

Sir,

Sub : Submission of E Tender documents - Providing additional well, tank and Maintenance works to Pulvetta WSS in Karuvarakundu GP, Malappuram District

Ref : Your e-tender Notification No. 04/SUS/KRWSA/RPMU/MPM/KAR/2022 Dated 25/11/2022

1. I/We.....on behalf of .....  
As the duly authorized person (s) in my/our official capacity as.....  
of the aforesaid firm, hereby submit this tender for your consideration. I / we have read and understood all conditions of this document in full spirit and meaning. I/We hereby agree to accept all the conditions put forth in the succeeding pages of this document without any deviations or with the exceptions, which may be expressly admitted and accepted by the tender accepting authority before the award of work. Preliminary agreement duly executed and signed in Rs. 200/- worth stamp paper is also enclosed. Copy of the specifications duly signed is also enclosed.
2. EMD for **Rs. 50,000/-** (Rupees Fifty Thousand Only) has been remitted through **internet banking facility only**.
3. I / We further agree to complete the whole work in all respects within 3 (**Three**) months from the date of award of work.
4. I/We agree to keep the tender open for acceptance for a period of **120 days** from the last date prescribed for submission of tender.
5. I / We agree that Authority shall without prejudice to any other right or remedy be at liberty to forfeit the said earnest money absolutely if :
  - a) In case we fail to keep the tender open as aforesaid or make any modifications in the terms and conditions of the tender.

- b) After the Tender is accepted, I/we fail to execute the agreement as provided in the tender conditions or to commence the execution of work as provided in condition.
- 6. The tender submitted is fully in accordance with NIT and I / we agree to all NIT conditions and any other conditions prevailing in KRWSA in Toto.
- 7. I have not included any conditions in quoting for this tender.

Yours faithfully

(Office Seal)

Tenderer

#### 4. PARTICULARS SHOWING STATUS OF TENDERER

- 4.1.1 Name of tenderer :
- 4.1.2 Address
- Permanent :
- Present for communication :
- E-mail ID / Fax / Telephone :
- 4.1.3 Status of the tenderer/individual or Public Ltd. :  
Co. or Private Ltd Co. or registered Partnership  
concern or proprietary concern
- 4.1.4 Name and address of Chairman of Board of :  
Directors and Managing Director/Managing  
Partner (in case of partnership concern) or  
Proprietor (in case of proprietary concern)  
[Memorandum of Articles and Authorization/  
Partnership deed]
- 4.1.5 Whether the tenderer is a registered Contractor :  
of KWA/PWD/any State /Central Government  
Department. (CPWD, MES, Railway etc) or  
local bodies (ie Port Trust, District Board,  
Municipality or a statutory body) with Reg. No.  
and year, issuing authority & validity period
- 4.1.6 Name and address of two responsible persons :  
(preferably Senior Engineers/ Officers of a  
Government Department, Quasi Government  
organization or a local body), to whom  
reference can be made regarding experience and  
performance.
- 4.1.7 Whether Authorization to act on behalf of the :  
firm presented or not

(OFFICE SEAL)

SIGNATURE WITH NAME & DESIGNATION

## 5. FORMS OF AGREEMENT

### (A) FORM OF PRELIMINARY AGREEMENT

"Preliminary Agreement entered on this ..... day of .....Two Thousand and Twenty Two, between the Regional Project director, RPMU Malappuram for and on behalf of Kerala Rural water Supply and Sanitation Agency of the one part and Sri. .... (full name and address of the tenderer). Here in after called the contractor of the other part for the execution of the agreement as well as for the execution of the work of Providing additional well, tank and Maintenance works to Pulvetta WSS in Karuvarakundu GP, Malappuram District Kerala Rural water Supply and Sanitation Agency (KRWSA) invited tenders for the work as stated above by Notification No. 04/SUS/KRWSA/RPMU/MPM/KAR/2022 Dated 25/11/2022 in [www.etenders.kerala.gov.in](http://www.etenders.kerala.gov.in) and the notice inviting tenders stated as follows :

Within **14 days** after the date when the acceptance of the tender has been intimated to him, the tenderer shall submit security deposit for the proper fulfillment of the same and shall execute an agreement for the work in the stipulated manner. If the contractor fails to execute the original agreement within the stipulated time, the earnest money shall be forfeited to KRWSA without any notice or in the case of the contract, fails to maintain a specified rate of progress and reason for delay is solely attributable to the contractor (to be specified in each case in the tender schedule) KRWSA shall terminate the contract as per the prevailing rules and rearrange the work at the risk and cost of the contractor and fresh tenders shall be called for or the matter otherwise disposed off.

If as a result of such measures due to the default of the tenderer to pay the required deposit to KRWSA results in any loss to KRWSA, the same will be recovered from him as arrears of revenue. The original contractor shall have no claim whatever to the sum that may be due to the contractor on this or any other subsisting contracts or under the Revenue Recovery Act or otherwise the KRWSA may decide.

NOW THESE PRESENT WITNESS AND it is mutually agreed as follows :

The terms and conditions for the said contract having been stipulated in the said tender form to which the contractor has agreed, a copy of which forms part of this agreement, it is agreed that the terms and conditions stipulated therein shall bind the part to this agreement extend to which they are abrogated or altered by express terms and conditions herein agreed to and in which accept the express provisions herein all supersede those of the same tender form.

1. The contractor hereby agrees and undertakes to perform/fulfill all the operations and obligations with the execution of the said contract work of Providing additional well, tank and Maintenance works to Pulvetta WSS in Karuvarakundu GP, Malappuram District (Here the name of the work) is awarded in favour of the contractor.
2. If the contractor does not come forward to execute the original agreement within stipulated time (maximum of 24 days, as per clause 7.22.2) after the said work is awarded and selection notice issued in his favour, the earnest money shall be forfeited to KRWSA without any notice. If the contractor commits breach of any of the conditions of the contract and not following the work schedule chart, stipulated in the NIT therein KRWSA shall terminate the contract as per the prevailing rules and rearrange the work at the risk and cost of the contractor, otherwise or loss so sustained by the KRWSA shall be realized from the contractor under Revenue Recovery Act as if arrears of land revenue as assessed, taking into consideration the prevailing PWD rate and after giving due notice to contractor. The acquisition taken by such authority officer or officers shall be final and conclusive and shall be binding on the contractor.



3. The tenderer further agrees that any amount found due to KRWSA under or by virtue of this agreement shall be recoverable from the contractor from his EMD and his properties movable and immovable as arrears of Land Revenue under the provisions of the Revenue Recovery Act for the time being or in any other manner as the KRWSA may deem fit in this regard.
4. The contractor further assures it is clearly understood that the settlement of claims either by part bills or by final bills will be made only according to the availability budget provision and allotment of funds to the Regional Project Management Unit, Malappuram under respective heads of account in which the work is sanctioned and arranged and also subject to seniority of such bills. No claim for interest or for damages whatsoever shall be made for the belated settlement of claims of bills.

IN WITNESS WHERE OF the Regional Project Director, RPMU Malappuram (here the name of the officers of the KRWSA) for on behalf of the Kerala Rural Water Supply and Sanitation Agency (KRWSA) and .....  
 .....the tenderer have set their hands on the day and year firm above.

Written signed by Regional Project Director, RPMU Malappuram/officers of Kerala Rural Water Supply and Sanitation Agency.

**REGIONAL PROJECT DIRECTOR**

In the presence of witness

- 1.
- 2.

Signed and delivered by

..... the contractor

In the presence of witness

- 1.
- 2.

Note: - The form should be presented in Rs. 200/- valid stamp paper of Govt. of Kerala.

(B) FORM OF FINAL AGREEMENT TO BE EXECUTED ON AWARD OF WORK

AGREEMENT No. :

Date :

**WORKS CONTRACT**

AGREEMENT entered into ..... day of the..... Two Thousand and ..... between the selected contractor, Sri. .... of the one part (hereinafter referred to as first party), Sri. ...., the Secretary, Grama panchayath Level Activity Committee, Karuvarakundu Grama Panchayath of the second part (hereinafter referred to as second party) and Sri. ...., the Regional Project Director, KRWSA, RPMU Malappuram, MMC.X/108-112, 2<sup>nd</sup> Floor, UMK Tower, Jubilee road, Uphill, Malappuram – 676505 (hereinafter referred to as third party) for and on behalf of Kerala Rural Water Supply and Sanitation Agency of the third part for the work of Providing additional well, tank and Maintenance works to Pulvetta WSS in Karuvarakundu GP, Malappuram District (herein after referred as work) by the former for the use of the Kerala Rural Water Supply and Sanitation Agency as per accompanying, plan, specification and conditions of contract approved by Kerala Rural Water Supply and Sanitation Agency under Sustainability Project 2022-23.

**1. Cost of the Contract**

The total cost of the works (hereinafter referred to as the “total cost”) is Rs. ..../- (Rupees .....Only) excluding GST but including all other taxes as reflected in accepted Bill of Quantities attached.

**2. Completion time**

The works should be completed within 3 months (90days) from the date of this Agreement. In exceptional circumstances, the time period stated in this clause may be extended in writing by mutual consent of all the three parties. If such circumstances arise, third party may approve the time extension with or without penalties as per rule, on getting written request from first party along with the recommendation letter of second party.

**3. Defect Liability Period**

The defect liability period will be 12 months from the date of completion and commissioning of the total works covered under this contract.

**4. Technical Supervision during Implementation**

The technical supervision of the work will be under the 3<sup>rd</sup> party or his authorized Engineering representatives and the other two parties are liable to follow the instructions of first party while implementation.

**5. Preparation of Measurements and Bills**

The measurements of the work will be recorded and billed by authorized Engineering representatives of third party based on actual valuation at site. Depending upon the implementation progress, the first party may request for bills along with the recommendation of second party and the third party or his authorized representatives may approve bills.

**6. Payment**

Payment will be released according to current KRWSA norms for Sustainability Project 2022-23 based on the following criterias :

- a. Payment to first party will be released by Third party or his authorized representative on getting

required documents from first party and second party.

- b. The second party hereby agree to mobilize and deposit their beneficiary share to the bank account mentioned for within the stipulated time frame as per KRWSA project norms.
- c. Depending upon the implementation progress, the first party hereby agrees to request and receive the payment by maximum 3 bills (2 part bill + 1 final bill) or one final bill.

#### **7. Tender Conditions**

All the three parties hereby agree to implement the work according to the tender conditions (NIT Volume 1&2, Price bid, Govt. orders & related documents) and Sustainability 2022-23 project implementation manual (Letter No. KRWSA-PMU/36/2018-TA(OP)-Part (1) Dated 15/10/2022).

#### **8. Problem solving & Dispute settlement**

All the three parties hereby agree to solve problems/disputes if any come up during implementation singly or by everyone's coordination. If any of them are not found to be solved in this way, the three parties hereby agree to follow KRWSA Executive Director's decision in this regard.

#### **9. Cancellation of Contract**

All the three parties are free to take decision separately or jointly, in cancelling or stepping back from this agreement in accordance with the tender conditions.

Signed and delivered by the above mentioned contractor (1<sup>st</sup> Party) :

In presence of witness :

- 1.
- 2.

Signed and delivered by the above mentioned GPLAC Secretary (2<sup>nd</sup> Party) :

In presence of witness :

- 1.
- 2.

Signed and delivered by the Regional Project Director, RPMU Malappuram on behalf of the Kerala Rural Water Supply and Sanitation Agency (3<sup>rd</sup> part):

In the presence of witness :

- 1.
- 2.

## 6. DEFINITIONS AND INTERPRETATIONS

1. '*Government*' means Government of Kerala.
2. '*Authority/KRWSA*' means the Kerala Rural water Supply and Sanitation Agency.
3. '*Project Management Unit (PMU)*' means the office of Project Management Unit, Thiruvananthapuram, Kerala Rural water Supply and Sanitation Agency. '*Regional Project Management Unit (RPMU)*' means the office of Regional Project Management Unit, Malappuram Kerala Rural water Supply and Sanitation Agency.
4. '*Executive Director (ED)*' means Executive Director (ED) at the office of Project Management Unit, Thiruvananthapuram, Kerala Rural water Supply and Sanitation Agency.
5. '*Director Technical (DT)*' means the Director Technical at the office of Project Management Unit, Thiruvananthapuram, Kerala Rural water Supply and Sanitation Agency.
6. '*Regional Project Director (RPD)*' means the Regional Project Director at the office of Regional Project Management Unit, Malappuram, Kerala Rural water Supply and Sanitation Agency.
7. '*Manager Technical (MT)*' means the Manager Technical at the office of Regional Project Management Unit, Malappuram, Kerala Rural water Supply and Sanitation Agency.
8. '*Senior Engineer (SE)*' means the Senior Engineer at the office of Regional Project Management Unit, Malappuram, Kerala Rural water Supply and Sanitation Agency.
9. '*Project Commissioner (PC) or Engineer in charge of work*' means the Project Commissioner at the office of Regional Project Management Unit, Malappuram, Kerala Rural Water Supply and Sanitation Agency.
10. '*Departmental Officers*' mean officers of the Kerala Rural Water Supply and Sanitation Agency not below the rank of an Project Commissioner in charge of the work.
11. '*Work*' means the work / project to be done as per the description in the tender document.
12. '*Tenderer*' means person or persons, firm or partnership or company or consortium of companies submitting a tender for the work as defined under item 8 supra, either directly or through duly authorized representatives.
13. '*Contractor*' means person or persons, firm or partnership or company or consortium of companies who have entered into contract for the execution of the work.
14. '*Drawing*' means the drawing referred to in the tender documents or such other drawings as may from time to time be furnished or approved in writing by the Regional Project Director.
15. '*Site*' means lands and other places, on, under, in or through which the work is to be executed or carried out or any other place provided by the Authority for the purpose of fulfillment of the Contract.
16. '*Departmental rate*' means rate worked out by the Authority based on departmental data and Schedule of Rates plus conveyance plus 10% towards contractor's profit except on the cost of materials issued departmentally.
17. '*Specification*' means the instructions, provisions, conditions and detailed requirements contained in the tender documents.
18. '*M.D.S.S*' means Madras Detailed Standard Specifications (Latest Edition).
19. '*I.S.S*' means Indian Standard Specification, ISO means International standard Organization and BIS means Bureau of Indian Standards. '*B.S. S*' means British Standard Specifications.

20. '*Approved / Approval*' means approval in writing.
21. '*Day*' means a day from midnight to midnight. '*Week*' means seven consecutive days. '*Month*' means from the beginning of a given date of calendar month to the end of the proceeding date of the next month.
22. '*Time tested*' means the performance of an item is in such a manner that it has successfully withstood the service conditions intended originally for a continuous period of not less than 7 years in the past without having shown any unpredicted and unpleasant effect and thus has proved the worthiness beyond doubt.
23. '*Lead Partner/partner in charge*' means the partner who is authorized by an agreement executed by all partners to receive any instructions / communications/ payments from KRWSA and to attend any discussions or other activities in respect of this contract on behalf of all partners.
24. '*Testing*' when a structure / component / equipment is tested to ascertain its strength/durability /material comparison with respect to design / service loads or performance to the satisfaction of the Engineer in charge or as stipulated in the scope of work or as per ISS /BSS, or any such standards / specifications, it is defined as testing.
25. '*Trial Running*' means putting all components together with the service / design conditions so as to ascertain the individual and combined performance of all works under the scope together, with respect to the design performance for a period specified in the scope of works.
26. '*Commissioning*' means having ensured satisfaction in performance with respect to design / service conditions in testing and trial running putting the works under the scope of work into desired real service conditions from a particular moment of time continuously or otherwise as envisaged.
27. '*Training*' means imparting of training to Authority staff with sufficient practical and theoretical knowledge for the operation and maintenance of the service system/ scheme and the knowledge for attending to emergency repairs or acting appropriately on emergency situations that may arise during the life time of the system, as included in the 'work'.
28. '*Manual*' means Manual on Water Supply and treatment third edition Revised and up dated May 1999 (or the latest) of Central Public Health and Environmental Engineering Organization.
29. '*MLD/mld*' means Million liters per day. '*LPS/lps*' means Litres per second
30. '*EPCM*' means Engineering Procurement, Construction and Management.
31. '*Maintenance*' means Maintenance for specified period during the guarantee period mentioned after full commissioning of project.
32. '*ETS*' Electronic tendering system and '*E-tender*' means electronic tender.
33. '*Tender*' refers to all documents submitted by the bidder through electronic media
34. '*FHTC*' means functional Household Tap Connection.

## KERALA RURAL WATER SUPPLY AND SANITATION AGENCY

### 7. TENDER CONDITIONS : PART –I

#### QUALIFICATION OF TENDERERS

- 7.1 The Regional Project Director, RPMU Malappuram, KRWSA for, and on behalf of the KRWSA propose to arrange the work of “Providing additional well, tank and Maintenance works to Pulvetta WSS in Karuvarakundu GP, Malappuram District”
- 7.2 The successful tenderer shall be entrusted with the work for the completion of the project as described in the "Scope of Works" in Volume II.
- 7.3 Deleted
- 7.4 The tenderers who have submitted the bids, shall be considered as qualified for consideration of their bids further only if they have valid and eligible contract licence (**A, B and C Class registration** from KPWD/KWA/CPWD/LSGD/Govt of India/Govt institutions) and GST registration.

#### 7.4.1 In case the tender is submitted as a JOINT VENTURE:

- i. There shall not be more than four partners in a joint venture and one partner shall be designated as lead partner.
- ii. The lead partner submitting the tender on behalf of the joint venture shall (a) submit complete information pertaining to each such partner and (b) state in the covering letter attached to the tender the name of the lead partner in charge duly authorized for submitting the tender which shall be evidenced by proper power of attorney signed by legally authorized signatories of all the partners.
- iii. Original or notary attested copy of the agreement confirming the intent of all parties to form a joint venture shall be attached with the tender. It shall also distinctly show:
  - a. The financial participation of each member of the joint venture and the responsibility of each member as regards the planning and execution of the work.
  - b. Name of the lead partner in charge who is authorized to incur liabilities and receive instructions for and on behalf of all/any of the partners of the joint venture during the entire period of the contract including any extended period, as well as for receiving payments due.
  - c. An undertaking to the effect that all the partners of the joint venture shall be jointly & severally responsible for the execution of the contract, in accordance with the terms and conditions of the contract.
  - d. A partner or a design consultant who has joined with the lead partner to compete in this bid shall not compete singly or in association with any other tenderer for this work. The tenderer while submitting his bid shall obtain an undertaking in this regard from his design consultant / partner and produce it along with the technical bid.
  - e. The aggregate of the qualification criteria of all partners together shall be sufficient to meet the requirements as if a single tender only on financial criteria.
  - f. A lead partner of the joint venture shall meet at least 40% of the qualification criteria in terms of annual turnover and net worth (if required) and any other partner shall meet at least 25% of the qualification criteria.

- g. The extent of participation of each partner shall be specified as also experience of all such partners in the relevant field. However, a partner only for design and consultancy shall not be reckoned for the purpose of clause (f) above.
- h. Where the tender submitted is as per clause (g) above for the purpose of attaining qualification as a design and management consultant of the prime contractor, then full information shall be given on the consultancy firm's proposed participation. An undertaking from the consultant for providing professional assistance to the contractor shall accompany the tender together with the complete details regarding the technical man power and experience of such consultant.
- i. Status of persons signing the tender on behalf of the firm in the event of the tender being submitted by a firm, the person signing the tender on behalf of the firm shall state his position in the firm as to whether he is the proprietor, partner or Manager etc. He shall also furnish with the tender, the letter or other documents (in original) authorizing him to act on behalf of the firm.

#### **7.4.2. CHANGE IN THE FIRM'S CONSTITUTION**

- 7.4.2.1 In the case of contract entered into by partnership firm, any change in the constitution of the firm shall forthwith be notified by the contractor to the Regional Project Director and to the officer with whom the agreement has been executed.
- 7.4.2.2 The contractor, shall not without the previous sanction in writing of the authority accepting the tender, execute any power of attorney in respect of any matter implying this contract and any such power of attorney executed without such sanctions shall not be recognized by or be binding up on the Authority either to grant such sanction or to refuse it or revoke a sanction once given.
- 7.4.2.3 In the case of partners who are in joint venture for executing the agreement, no change in the individuals of the firm shall affect the liability of the person who may sign the agreement. Any such change shall be forthwith notified by the contractor to the Agreement Authority and the Regional Project Director for information.

#### **7.5 TENDERS TO BE IN PRESCRIBED FORM**

Tenders, which are not submitted in the prescribed form, shall be summarily rejected.

#### **7.6 HOW TO SUBMIT THE BID**

The tenders shall be submitted electronically to the Regional Project Director, RPMU Malappuram, KRWSA in the method available at the web site [www.etenders.kerala.gov.in](http://www.etenders.kerala.gov.in). The tenderer has to remit the amount towards cost of tender documents and EMD through online payment in time. The bid submission is allowed up to the last date and time given in this tender notice. Submitting bid documents in no way for a right or / eligibility for qualification of awarding the work. The qualification criteria are described in the bid document.

The price bid shall be submitted electronically only.

The bidder shall fill up the details and price bids in prefixed formats along with NIT, Scope of work or any other document uploaded by the Regional Project Director, Kerala Rural Water Supply and Sanitation Agency, RPMU Malappuram and upload in the website. Additional documents if any are to be scanned and uploaded in the website. The price bid shall be submitted electronically only. The tenderer shall produce before the originals of the documents uploaded including those scanned and uploaded (except price bid) with the preliminary agreement executed in the prescribed Kerala Stamp paper (Rs.200) if requested. In the event of discrepancy between the scanned copy and the original

submitted or if the tenderer fails to submit the documents within the prescribed time, the tender submitted by the tenderer will be summarily rejected and the EMD forfeited.

**Volume I** -This part should contain NIT and relevant details as per the NIT conditions. This should also contain all information required for the qualification of the tenderer.

**Volume II- Scope of work and Bill of Quantities.**

### **7.7 HOW TO SUBMIT QUALIFICATION BID**

7.7.1 It is mandatory that qualification application shall contain the following.

- a. Contractors attending the bidding shall attach the copy of Contract license through electronic Medias.
- b. Contractors attending the bidding shall attach the copy of their GST Registration certificate.

7.7.2 Deleted

7.7.3 All details furnished should be complete and as applicable four months prior to the last date of submission of tender.

7.7.4 Applicants are particularly advised to fill the details strictly as per the para 7.17.1. Applications will be rejected if required details are not furnished and if it do not meet the minimum qualifications/ requirements mentioned anywhere in this document. **Any formats furnished in lieu of prescribed formats will not be accepted.** The applicants may furnish any additional information, which in his opinion will highlight his capacity to perform, along with the attachments.

7.7.5 While, applications are under consideration, applicants and their representatives or other interested parties are advised to refrain from contacting by any means KRWSA officers on matters related to the applications under scrutiny. Applicants will not be permitted to change the substance of their applications after they have been opened. Noncompliance with these provisions shall be a cause for disqualification.

7.7.6 No firms/ partner of any firm, consultant including design consultant or individual be who have submitted the tender for a work shall associate with any other bidder in the particular tender. EMD in such cases shall be forfeited both the tenders will be treated as rejected

### **7.8 HOW TO SUBMIT THE TECHNICAL BID (Cover – B Part II)**

7.8.1 There shall be a brief description of the systems offered as a prelude to the bid under the title "Brief description of the systems offered" and numbering each of the paragraphs. This shall be followed by details of the civil structures under the title "Particulars of civil works." This shall contain the particulars regarding length, breadth, total height, water depth and sizes of the different

Components and the specifications of the materials proposed for construction of the various parts of these components and the method of execution.

The tenderer is bound to execute all the works described in NIT even though if it is not expressed in brief description of systems offered by the contractor.

7.8.2 The details shall, wherever possible, be furnished in the form of rows and columns (Tables) for enabling a quick evaluation of the offer,

7.8.3 Deleted



7.8.4 Drawing required for explaining the scope of work is appended in annexure

7.8.5 Deleted

7.8.6 Deleted

7.8.7 The documents of the Technical bid as per Clause: 7.8.1 to 7.8.4 shall be arranged in the same order.

7.8.8 The itemized schedule of works explained under the scope of works is furnished in the Part 2.

The cost or rate shall not be disclosed anywhere in this sheet, as it shall render the tender invalid.

#### 7.8.11 ALTERNATE OFFERS AND DEVIATIONS

Any alternative offer deviating from the scope of work and specifications provided in the NIT will not be entertained and shall render the tender invalid.

#### 7.9 HOW TO SUBMIT THE PRICE BID

7.9.1 The price bid in format BOQ should be submitted electronically only. **The cost or rate shall not be disclosed anywhere in this sheet, as it shall render the tender invalid.** The price Bid shall be submitted only in the format specified for that purpose (Form BOQ).

7.9.2 The price bid shall not be used for expressing or putting forth any techno-commercial conditions of the tender. Violation of this stipulation shall result in rejection of the tender after the opening of the price bid even if it may happen to be the lowest.

#### 7.9.3 VARIATION OF PRICE BID

The tenderer is bound to carry out the work as per the specification at the quoted rate. Nothing inferior to specification as per the scope of work included as part of this NIT shall be acceptable. Price variation on any account shall not be permitted if not explicitly specified otherwise in this NIT and the tenderer is expected to follow sound engineering practices in his designs and cost calculations. Changes in statutory taxes/levies, if any, shall be applied on cost of pipe in case of pipeline works, involving pipe supply. In all such cases the duties, levies, and taxes in percentage that he has considered in the quoted amount and the cost of pipes shall be declared by the tenderer while submitting his price bid. Any escalation/ reduction in statutory duties and levies will be applied only on the basic price of pipes and specials. No escalation in statutory taxes, duties and levies etc. shall be allowed beyond the original approved period as per the procurement schedule, accepted and included in the agreement.

#### 7.10 ATTESTATION OF CORRECTIONS AND ADDITIONS

Care shall be taken to prepare the tenders without corrections/over writings / erasing etc. However, if any corrections, additions or pasted slips shall become necessary, the same shall be signed by the tenderer.

#### 7.11 LANGUAGE AND CORRESPONDANCE OF THE TENDER

Tenders shall be submitted in English and all information in the tender shall be in English. Information in any other language shall be accompanied by its translation in English. However, the details as read in the English text will be governing. Failing to comply with this direction may be considered as a sufficient reason for disqualifying a tender. Any communication should be in writing. Tenderers can make correspondence with the tendering authority through E mail, by fax, or by post.

## 7.12 CERTIFICATE OF NON-RELATIONSHIP

1. Persons related to any officer of the KRWSA, who is in charge of or having control over the work, are strictly prohibited from tendering for the work. Relationship in this respect is restricted to father, mother, husband, wife, son, daughter, brother, sister, nephew, father-in-law, brother in-law, mother-in-law, sister-in-law and first cousin of the officer concerned. The tenderers shall declare that they are not related to any officer of the KRWSA who is in charge or having control over the work as given in Annexure I.

2. If at any stage, the above condition is found to have been contravened, the earnest money /security deposit of the tendered shall be forfeited and contract entered into shall be cancelled and the work arranged at his risk and cost.

## 7.13 FIRM PERIOD OF TENDER

Tenders shall be firm for acceptance for a period of **120 days** from the last date prescribed for submission of tender. No tender can be withdrawn or altered before the firm period is over. Any tenderer who withdraws or alters the tender before the expiry of the firm period shall do so at the risk of the tenderer and the earnest money will be forfeited to KRWSA.

## 7.14 PERIOD OF COMPLETION

The work shall be completed in all respects within **3 (Three) months** from the date of Agreement. This period of execution is inclusive of the monsoon season.

## 7.15 AGENCY ACCEPTING THE TENDER

The final acceptance of the tender vests with the KRWSA/ State Government which is not bound to accept the lowest tender or assign any reason for rejecting any tender. The Agency reserves to itself the right of re- advertising the tender for the work for carrying out the work in any manner that may be deemed fit, subsequent to this invitation of tender.

## 7.16 EVALUATION OF TENDER

The tender submitted by a tenderer/firm shall be evaluated in two phases.

**First stage** : Qualification of tenderers

**Second stage** : Evaluation of price bid of the qualified tenderers.

## 7.17 EVALUATION OF QUALIFICATION APPLICATION

Evaluation as per documents 7.7.1

### 7.17.1 MINIMUM ELIGIBILITY CRITERIA FOR QUALIFICATION.

The applicant must be a well-established Registered contractor with experience and capabilities in executing works similar to the work tendered. The applicant can either be a single or a joint venture as per clause 7.4.1 of this NIT. The minimum qualification expected for eligibility for qualification will be based on the following.

Contractors having valid and eligible contract **licence (A, B and C class** registration) from KPWD/KWA/CPWD/LSGD/PWD in other states of India/CPWD/Central/State PSUs and GST registration.

7.17.1.1 Deleted

7.17.1.2 Deleted

1. Deleted
2. Deleted
3. Deleted
4. Deleted
5. (a) Deleted
5. (b) Deleted
6. (a) Deleted
- 6 (b) Deleted

7. A tenderer who has lagged two or more works of KRWSA shall not be considered as qualified. Contractor shall submit an undertaking clearly certifying that he has not delayed two or more works of KRWSA in the past ten years prior to the date of tender as per Annexure II.

8. Deleted.

7.17.1.3. ORGANISATIONAL CAPACITY: The contractor should engage at his own cost a diploma holder (Civil Engineering) with sufficient practical experience for the proper execution and supervision of works costing from Rs. 2 Lakhs to Rs. 5 Lakhs and one Engineering Graduate and Diploma Holder (Civil Engineering) for works costing Rs. 5 Lakhs up to Rs. 10 Lakhs and one Engineering Graduate and two Diploma Holders for works costing over 10 Lakhs

7.17.1.4 TECHNICAL CAPABILITY Deleted

(A) TECHNICAL PARTICULARS AND DESIGN Deleted

B) PROJECT MANAGEMENT STRATEGY Deleted

7.17.1.5 Deleted

7.17.1.6 In case of joint venture partnership, The experience of the partners may be added together for explaining the capacity for qualification. It should be ensured by the tenderer that all the documents furnished are duly verified and authenticated by him. No additional documents will be accepted after the submission of the tender.

7.18 Offers are liable to be rejected if

- 1) **The information given in the documents found incomplete / misleading or false (such application will be considered as non-responsive)**
- 2) **The facts are misrepresented. (in this case the EMD is liable to be forfeited).**
- 3) **The records of poor performance are found out at any time after submission of bid.**
- 4) **The contractors who are blacklisted or failed to complete the works, or refrained from executing the agreement and completing the work which they had agreed in the tender.**

7.18.1 Tenders will be rejected if

- 1) **EMD is not proper and sufficient**
- 2) **NIT is not accepted in toto**
- 3) **If the tender is conditional**

7.19 The successful bidders who are qualified in the qualification evaluation will alone be considered while evaluating price bid.

#### 7.19.1 WITNESSING OF TENDER OPENING

Only one authorized representative will be permitted to witness the bid opening as in clause 7 of Detailed Tender Notice in Chapter 2.

#### 7.20 FINAL DECISION MAKING AUTHORITY

The Agency reserves the right to accept or reject any of the applications for qualification without assigning any reasons thereof and Agency's decision shall be final.

#### 7.21 PERFORMANCE GUARANTEE.&ADDITIONAL PERFORMANCE GUARANTEE

The Performance guarantee, Additional performance guarantee and Performance security deposit shall be applicable to this tender as per GO (P) No.429/15/Fin dated: Thiruvananthapuram 28/09/2015, GO(P) No.19/2016/Fin dtd.03.02.2016, GO(P) No.124/2016/Fin dtd.29/08/2016, GO(P) No.168/2018/Fin dtd.02.11.2018, and GO(P) No.1/2019/Fin dtd.10.01.2019, GO (P) No.7/2021/Fin dated 07.01.2021 or any other prevailing G.O.s applicable to KRWSA (*Copies of G.O.s given separately*).

(I) **Performance Guarantee**, the amount collected at time of executing contract agreement, will be 5% of the contract value (agreed PAC) and the deposit will be retained till the expiry of Defect Liability Period. At least fifty percent (50%) of this deposit shall be collected in the form of Treasury Fixed Deposit and the rest in the form of Bank FD or any other forms prescribed in the revised PWD Manual.

#### (II) **Additional Performance Guarantee.**

Additional Performance Guarantee will be required in all cases where quoted rate falls below 10% of the estimate cost but the maximum permissible lower limit is 25% below the estimated cost. The 10% standard exemption will be applicable to all estimates quoted below estimate cost upto 25%. If the rate quoted by the contractor is "x%" below estimate cost (where x lies above 10% and upto 25%) the performance guarantee for an amount equal to (x-10)% of the estimate amount shall be obtained from the contractor.

The tender with lowest quoted rate less than 75 % of the estimated PAC (below 25 % of estimated PAC) shall not be rejected if sufficient competition is ensured and the rate quoted by the second and third lowest bidder are also comparatively nearer the lowest bidder. The tender inviting authority shall obtain a statement from the lowest bidder quoting rates below PAC regarding the reasonableness of the rate quoted to assess that whether the quoted rates are workable. If the contractor quotes less than 75% of the estimated PAC and variation with all other quoted rates are much higher, the Tender accepting authority shall take appropriate decision based on merit.

#### 7.22 EXECUTION OF AGREEMENTS

7.22.1 Preliminary agreement in Rs. 200/- Kerala Govt. Stamp Paper duly filled up and signed is to be enclosed in Cover A.

7.22.2. The successful tenderer shall before commencing the work, execute an agreement within 14 days from the date of award of the work in Kerala State Government stamp paper of the required value for the due fulfilment of the contract. He shall pay for stamps, forms and legal expenses incidental thereto. Before executing the agreement, the contractor shall finalize his procurement and project implementation schedule, which shall

form part of the agreement. In case the tenderer fails to execute the agreement within 14 days, he shall be fined for such lapses as per clause 8.11(B) [c.i]. Any work recorded as done during the period between the award of work and the end of period allowed to execute agreement will be treated as an asset to KRWSA and no claim will be allowed for the selected tenderer. If the successful tenderer fails to deposit the security amount and execute the agreement as specified above, the EMD of the tenderer shall be forfeited to Agency and the work shall be arranged otherwise. If as a result of such measures due to the default of the tenderer to pay the requisite security deposit, sign contracts and take possession of the worksite, the Agency incurs any loss, the same shall be recovered from him, but should it be a savings to the Agency, the original contractor shall have no claims to the difference. Recoveries on this or any other account shall be made from the sums due to the contractor on this account or otherwise as the Agency may decide, including Revenue Recovery Proceedings, as if the loss is arrears of land revenue.

#### 7.23. COMMUNICATIONS TO BE IN WRITING

All notices, communications, references and complaints issued or made by the Agency, the Regional Project Director, RPMU Malappuram, KRWSA or by any such officers of the Agency and by the contractor with regard to this work shall be in writing and no notice, communications, reference of complaint not in writing shall be valid. All complaint notices, communications and references shall be deemed to have been duly made, given or sent to the Contractor, if delivered to the Contractor or his authorized agents in person with acknowledgement or posted to the address given by the Contractor or his authorized agent and such communication, if sent in service by post shall deemed to have been received by the addressee on the date on which the same should have reached such address in the ordinary course of transmission by post and in other cases, on the day on which the same were delivered or left.

#### 7.24 ORAL AGREEMENTS NOT BINDING

The terms of contract cannot be added to varied or reduced by any oral agreements previous or subsequent to its signature. The Agency will repudiate any such oral agreement.

**Regional Project Director**

# KERALA RURAL WATER SUPPLY AND SANITATION AGENCY

## 8. TENDER CONDITIONS: PART –II

### 8.1 TENDERS ARE TO BE IN PRESCRIBED FORM

All the submittals under this tender shall be in the prescribed form. Tenders which are not submitted in the prescribed form shall be summarily rejected.

### 8.2 PURPOSE OF THE CONTRACT

All the works executed/ facilities installed under this contract shall perform the services they are intended to do to the utmost satisfaction of Kerala Rural Water Supply and Sanitation Agency, without any defects whatsoever for a minimum period of 12 months from the date of completion and commissioning of the total works covered under this contract.

### 8.3 ALTERATION IN DRAWINGS SPECIFICATIONS ETC

8.3.1 The preliminary drawings and connected details enclosed are only for the reference of the tenderer. The tenderers shall conduct their own specific studies and detailed investigations based on the scope of works before offering the bid amount.

8.3.2 The Authority shall be at liberty to shift the location of structure or component of work within the periphery of the site shown in the site plan at any stage before the commencement of the actual execution of the work and the tenderer shall have no claims for any extra or enhanced rate on this account.

### 8.4 EXAMINATION OF THE SITE CONDITIONS, DRAWING ETC

8.4.1 The Authority does not accept any responsibility for the correctness of the description of the preliminary drawing and specifications. These are liable to alterations by omissions, deductions or additions as set forth in the conditions of contract.

8.4.2 The attached preliminary sketches, drawings, specifications, contours etc may become liable to changes at the present situation. The tenderer should verify and ascertain the correctness of these. The submission of the tender shall deem to be prima -facie proof that the tenderer has made such an examination and that this tender is based on the actual situations.

8.4.3 The tenderer shall examine carefully the proposal, drawings and specifications. They shall satisfy themselves as to the character, quality and quantities of the work to be performed, the materials to be supplied and the requirements of the contract with reference to the site and soil conditions. If the tenderer finds any discrepancies or omissions in the drawings, specifications or the tender documents or he should be in doubt as to the true meaning of any part thereof he shall make a written request to the Tendering Authority within 30/11/2022, 11.00 AM. Clarifications, corrections or modifications considered necessary in the tender documents shall be issued by the Tendering Authority to all intending tenderers who had purchased the tender form. The scope of works provides the requirement of Authority in this work. The information on the site conditions, sub soil investigation reports etc. as available with the Authority at present are furnished with the tender documents. The soil investigation reports, information as to maximum water level, minimum water level etc. if furnished in the scope of work have been collected from reliable sources. But the Authority does not certify the correctness of the information. The tenderers shall examine this information critically and ascertain the correctness to their satisfaction. Relying on any information without verifying the correctness/authenticity and thereby leading himself to any loss shall be at the risk of the tenderer. Authority shall not bear any responsibility on such accounts.

8.4.4 The tenderer shall specifically note that the bearing capacity and other details of soil and sub soil indicated is only approximate and that the Authority does not give any guarantee regarding their

present accuracy. The tenderers shall carry out their own tests visual and field to ascertain the bearing pressure and other details of soil and sub soil at various points before submitting the tender, if they so desire. The Authority shall in no way be liable for payments of any extra amount on account of any variation in the actual bearing capacity or other details of soil and sub soil resulting in any changes in design of foundation of structures etc.

8.4.5 Deleted.

## **8.5 Deleted**

## **8.6 PRE BID MEETING**

~~A pre bid meeting will be conducted by the tendering authority on the date mentioned in the tender notice. Any queries/doubts, which the tenderers may have on the scope of work or tender conditions, shall also be cleared by e-mails / correspondence up to ..... Any decision regarding changes in NIT conditions / scope of work taken in the pre bid meeting shall be final and the same will surpass the original conditions.~~

## **8.7 SELECTION OF LOCATIONS IN THE SITE**

- a) In respect of structures/works other than pipeline works the proposed structures at the site shall be located in such a manner that the different structures form a compact unit leaving maximum possible area at the site to facilitate future expansion. However, there shall be adequate passage facilities in between, as the circumstances or surrounding areas may demand. Notwithstanding the above condition the tenderer is liable to make essential alterations in the layout during the time of actual execution as may be deemed fit by the Engineer in Charge at no extra cost.
- b) In case of pipe laying works along a public road, the alignment of the pipe line shall be selected giving prime importance to the following points over economy for technical advantages due to the hydraulics or other similar advantages.
- c) The various traffic along the road shall not be blocked except under unavoidable conditions, if necessary, work should be arranged at night without extra cost.
- d) Every possible effort shall be taken to see that the traffic is normal and be permitted with minimum constraints at unavoidable circumstances and need not be blocked.
- e) When blocking of traffic is unavoidable the work shall be arranged in such a manner that blockage can be lifted/relaxed in the shortest possible time under all probabilities.
- f) The alignment runs along the sides of the roads through the berm/close to one side and intrusion to the hard surface/tarred surfaces of pathway to the barest minimum extent only if unavoidable.
- g) Wherever blockage of traffic / imposition of constraints in traffic is unavoidable, prior sanction of the concerned Authority / Department shall be obtained. The contractor shall do all liaison works in such cases.
- h) Giving prior information to police / traffic department, display of caution and notice boards at appropriate places, lighting watching etc. shall be the responsibility of the contractor, but all such information shall be given through the engineer in charge of the works.
- i) Caution regarding existing underground cables of electricity, telecom and other on - ground structures like electric poles, telephone junction boxes, water pipe lines etc. shall be the contractor's sole responsibility.

## **8.8 MOBILISATION ADVANCE**

No mobilization advance shall be paid to the contractor. However the contractor shall raise a claim for 80% of the value of the tested materials he has supplied at site, at the estimate rate or at his quoted rate whichever is less, which shall be considered by the authority in accordance with the relevant provisions of

the rules for release of secured advance in KRWSA. Sanctioning of such secured advances shall be at the discretion of the agreement authority and shall not be taken as a right of the contractor.

#### **8.9. I Deleted**

#### **8.10 PENALTY**

The contractor for the work shall be liable to pay penalty for the delay in executing the agreement, commencing work etc. as per the provisions of G.O (P) No.84/97/PW& T dated 19.8.97. The Engineer in charge shall also have power to measure up the work of the contractor and later such part as shall be unexecuted out of his hands, and to give it to another contractor to complete, in which case, any expense which may be incurred in excess of the sum which would have been paid to the original contractor, if the whole work had been executed by him (of the amount by which it exceeds, a certificate in writing of the Regional Project Director, shall be final and conclusive) shall be borne and paid by the original contractor and may be deducted from any money due to him by Authority under the contract or otherwise, or from his security deposit or the proceeds of sale thereof, or a sufficient part thereof. In position of penalty shall be, ho waver, without prejudice to the rights of Kerala Rural water Supply and Sanitation agency to terminate the contract as per the provisions of the agreement. All other conditions are as per G.O, (P) No.84/97/PW&T dated 19.8.97.

#### **8.10.1 LIQUIDATED DAMAGES**

Liquidated damages shall be levied at the rate of 0.1% of the cost of balance works for every one week of delay occurred in completing the whole work subject to a maximum of 10% of the contract value. Further, to ensure good progress during the execution of work, the contractor shall be bound, unless the contract provides otherwise, in all cases in which the time allowed for the work to reach any of the set stage of completion/ milestones as per the agreed time schedule of the work, exceeds one month, the contractor shall be liable to pay damages at the rate of 0.5% of the cost of balance works that should have been completed by that time, provided always that the entire damages to be paid under the provision of the 'clause shall not exceed 10% of the contracted value of work which should have been completed by then. All the damages payable under the provision of this clause shall be considered as liquidated damages, to be applied to the use of the Authority without reference to the actual loss sustained owing to the delay. Any appeal of the contractor against the liquidated damages charged against such lapses on his part shall be placed before and disposed of by the Authority.

#### **8.11 EARNEST MONEY DEPOSIT (EMD)**

- A. EMD shall be in the form of DD/Call deposit from a Scheduled Bank drawn in favour of the Regional Project Director, KRWSA, RPMU Malappuram (Tendering Authority).

The EMD for this particular work is Rs. 50,000/- (Fifty Thousand only). No exemption shall be allowed for Govt/ Quasi govt. undertakings unless there is specific order from government / KRWSA to that effect for this particular work. Any such order received from KRWSA, if exists, shall be submitted.

Earnest Money Deposit (EMD) is collected to ensure serious participation in the bidding process and this amount will be returned soon after finalizing the lowest bidder. Taking into consideration of the fact that fixing higher amount will reduce competition the rates of EMD has been revised as follows:

<b>Cost of work</b>	<b>Amount of EMD</b>
i) Upto Rs.2 Crore	i) 2.5% of project cost, subject to a maximum of Rs.50,000
ii) Above Rs.2 Crore upto Rs. 5 Crore	ii) Rs. 1 lakh
iii) Above Rs. 5 Crore upto Rs. 10 Crore	iii)Rs. 2 lakh
iv) Above Rs. 10 Crore	iv) Rs. 5 lakh



## **B. FOREFEITING OF EMD**

Authority shall without prejudice to any other right or remedy be at liberty to forfeit the said earnest money absolutely if :

1. In case the tenderer fail to keep the tender open as aforesaid or make any modifications in the terms and conditions of the tender which are not acceptable to the Authority.
2. After the Tender is accepted, if the tenderer fail to execute the agreement as provided in the tender conditions.

## **C. REFUND OF THE EARNEST MONEY DEPOSIT TO UNSUCCESSFUL TENDERER**

The earnest money deposit of the unsuccessful tenderers shall be refunded after the tenders are disposed of.

## **D. Deleted**

## **8.12 INITIAL SECURITY DEPOSIT AND RETENTION AMOUNTS**

*(Performance Guarantee, Additional Performance Guarantee, Performance Security Deposit)*

The successful tenderer shall within **fourteen days** of receipt of the order of award of work (selection notice), shall deposit a sum equal to 5 (Five) percent of the contract value as security for the proper fulfilment of the work. At least fifty percent (50%) of this deposit shall be in the form of treasury fixed deposit and the rest in the form of bank guarantee and or any other forms prescribed in the revised PWD manual.

8.12.1 The Performance guarantee, Additional performance guarantee and Performance security deposit shall be applicable to this tender as per GO (P) No.429/15/Fin dated: Thiruvananthapuram 28/09/2015, GO(P) No.19/2016/Fin dtd.03.02.2016, GO(P) No.124/2016/Fin dtd.29/08/2016, GO(P) No.168/2018/Fin dtd.02.11.2018, and GO(P) No.1/2019/Fin dtd.10.01.2019, (*Copies of GOs given separately*).

8.12.2 No exemption shall be allowed for initial security deposit and retention amounts for Govt/ Quasi Govt. undertakings unless there is specific order from government to that effect for this particular work and approved by the Authority.

## **8.13 INTEREST ON SECURITY AND RETENTION**

**8.13.1** No interest shall be payable upon the security deposit, or amounts payable to the contractor under the contract. **8.13.2** The Authority shall have the exclusive right to collect interest on all Govt. Securities or National Savings Certificates endorsed as aforesaid and all interest collected shall be credited to the accounts of the contractors and the contractor shall not be entitled to claim any sum by way of interest or profit on the said securities or National Savings Certificate, save the amount actually collected by the Authority. The interest so collected may either be refunded or adjusted against the contractor's security at the end of each financial year.

**8.13.3** The Authority shall not be liable for any depreciation in the value of securities while at its charge nor for any loss of interest thereon.

## **8.14 REPAYMENT OF SECURITY DEPOSIT**

**8.14.1.** For pipe laying works alone, the work will be treated as 'completed' when it is ready for commissioning of all allied civil works with anchor blocks and thrust blocks including fitting of all valves, specials etc. without any gap closing works in the pipeline alignment and after completion of testing of pipeline laid. Then completion certificate will be issued by the Engineer

in charge of the work within one month. Release of performance guarantee, additional performance guarantee and performance security deposit will be as per GO(P) No.429/15/Fin dated: Thiruvananthapuram 28/09/2015, GO(P) No.19/2016/Fin dtd.03.02.2016, GO(P) No.124/2016/Fin dtd.29/08/2016, GO(P) No.168/2018/Fin dtd.02.11.2018, and GO(P) No.1/2019/Fin dtd.10.01.2019, (*Copies of GOs given separately*).

**8.14.2.** If there is any reduction in the value of the security deposit by reason of any depreciation in the value of Government Securities, the contractor shall within thirty days of such reduction, make good, in cash or in pledge able securities of National Savings Certificate which shall be suitably endorsed as aforesaid any sum of sums which may have been deducted from or realized from the Sale of his security deposit held in Government securities or any part thereof or from the security deposit held in cash, or any such by which the value of Government Securities has depreciated.

**8.14.3** The refund of the security deposit as stated above shall however be, subject to the condition that if such time, where shall remain to be executed by the contractor any work as per the agreement or for the proper functioning of the system ordered during such period, the Authority shall be entitled to withhold payment until the completion of such work, so much of the security deposit as shall in the opinion of the Agreement executing authority, represent the cost of the work so remaining to be executed.

**8.14.4.** Even when various deductions is made against the bank guarantee it shall be the responsibility of the contractor to attend at his cost, works which are essential to make the scheme functional.

#### **8.15 ~~LUMP SUM AMOUNT/ITEM RATE/PERCENTAGE RATE~~ TO BE QUOTED FOR THE WORK**

**8.15.1** Bidders shall quote ~~lump sum amount / percentage rate/~~ Item rate for the work in the prescribed form provided in the tender document and shall be uploaded electronically. There shall not be any indication of the bid amount in any of the documents/papers of technical bid uploaded in which case the tender shall be rejected outright.

For payment purposes, upon execution of agreement by the successful bidder a payment schedule (Billing breakup) shall be prepared by the agreement authority in accordance with the sanctioned estimate of Kerala Rural Water Supply and Sanitation Agency and shall form the basis for billing.

**8.15.2** GST will be applicable for this contract.

All bidders should have a valid GST registration. The rates quoted by the bidders shall include all taxes and duties, construction workers welfare fund contribution, etc. except the GST. The rate quoted **shall be exclusive of GST** which may be paid or become payable on the completed work within the scope of this tender. In other words the amount quoted shall be exclusive of GST prevailing as on the due date of the tender and other taxes at applicable rates shall be deducted from the payments to the contractor as per rules without further correspondence. Separate column is provided for quoting the applicable percentage of GST in price bid. The deductions from contractor's payment shall include Income Tax, and Labour welfare fund as per the rate in force. However this shall not mean that only this amount shall be deducted. The payments and deductions shall be made as per Circular No. 18/2019/Fin dated 01/03/2019 of the Finance (Industries and Public Works –B) Department, Government of Kerala. (*Copy of the circular is attached for reference.*). Any tax rules issued by Govt. as and when will be applicable to this tender.

#### **8.16 PAYMENTS TO THE CONTRACTOR**

**8.16.1** Deleted

a) Deleted

- b) Deleted
- c) An amount of at least 5% of the total contract value shall be set apart for trial running and commissioning. If the trial running and commissioning is delayed, not due to the fault of contractor, after six months from the date of completion the above 5% can be released against Bank Guarantee.
- d) An amount equal to 1% of the total contract value shall be set apart for one year of maintenance period, commencing after completion and commissioning in form of bank guarantee pledged in the address of Tendering authority.

**8.16.2** For the purposes of payments the bills are categorized into:

- a) Part-Bill - Running Account Bill - Work in progress.
- b) Part - Bill - Running Account Bill - Work in progress.
- c) Part and Final Bill/Final Bill - Contract scope completed.

Or

A single final bill

**8.16.3** Part bills of categories (a) and (b) shall be paid in accordance with the valuation taken from site deducting the statutory deductions as sale tax, works contract tax, income tax or such other dues livable by the Government at source as per the laws prevalent from time to time during the tendency of the contract and other deductions as per the contract agreement.

**8.16.4** deleted

**8.16.5** Bills of category (c) shall be treated as final bill and shall be paid as per rules prevalent in the Authority after effecting the deductions of taxes, duties etc.

**8.16.6** The contractor shall prepare and submit the bills for payment with details of measurements for the quantum of work done. The measurements will be verified by competent Engineer in charge of the work and transfer to Measurement Book issued by authority for this purpose and submitted to the Manager Technical in charge of the work. No work will be paid for unless thoroughly good and fully in accordance with the specifications. Should through inadvertence bad works be passed and paid for, it will nevertheless be perfectly competent, for the Regional Project Director to strike the same out of the account at any future time and recover the value at any date previous to or at the time of granting the final certificate. The Authority, however, reserves the right to decide and allow/pass the bill submitted by the contractor for payment based on the overall priorities and the delay / non - payments of part bill by the Authority within 30 days of its submission by the contractor shall not entitle him for any compensation against the delayed payments nor shall it be taken as a reason for not maintaining the progress of the work.

**8.16.7** Bills of value less than 10% of the total amount of the contract shall not be presented unless they are of categories c and e. There shall be a minimum period of 30 days between two consecutive bills raised by the contractor. The maximum number of on account bills including the 90% bill shall be 10 nos.

**8.16.8** Delete

**8.16.9** Bill may be submitted by the contractor as soon as the stage of the work for interim payment is completed and Engineer in charge shall take the requisite measures for having the same evaluated and the admissible claim as far shall be allowed as per Clause 8.16.5. Certified progress report of the Regional Project Director shall be an accompaniment to the bill.

**8.16.10** Deleted

**8.16.11** "On account payments made to the contractor shall be without prejudice to the final making up of the accounts (Except where measurements are specifically noted in the measurement books as final measurement and as such have been signed by the contractor) and shall neither be considered nor used as evidence of any fact stated in or to be inferred from such accounts nor of any particular quantity of work having been executed nor of the manner of its execution being satisfactory.

**8.16.12** From the "On account" payments, deductions shall, be made by the Authority at the rate of 1 % of the amount of bill, excluding cost of departmental material if any supplied, towards contribution to the Kerala Construction Workers Welfare Fund Board.

**8.16.13** In case of any dispute arising out of the supply of ISO marked pipes, the Kerala Rural Water supply and Sanitation Agency shall be indemnified by the contractor, to the effect that all liabilities shall be borne by the selected contractor and the Kerala Rural Water supply and Sanitation Agency's responsibility shall end with the payment for the measured quantities in accordance with the agreement for the work.

**8.16.14** Interest for delayed payments: The tenderer/contractor must clearly understand that the settlement of claim either by part bill will be made only according to the availability of budget provision and allotment of funds made with the RPMU Office under the respective head of account in which the work is sanctioned and arranged and also subject to the seniority of such bills. No claim for interest or for damages whatsoever shall be made for the belated settlement of claims of bills. No such claims shall be admitted by the Authority.

**8.16.15** As built drawings of the facilities installed shall be a prerequisite for the payment of 90% bill which will be paid on completion and testing of all the work but for trial run.

**8.16.16** Checklist before making payment which would ensure quality of pipes and quality of work and workmanship should be adopted and its tracking should be done.

## **8.17. FINAL BILL**

**8.17.1** The final bill shall be submitted by the contractor within one month of the completion of the work as otherwise the Engineer in charge's measurement shall be accepted as final and binding.

**8.17.2** Deleted

**8.17.3** If any amount which by virtue of this contract, may become due to the contractor be not claimed for payment within three months from the date on which it falls due, the same shall be placed in deposit account and if the amount as placed remains for three years thereafter, the contractor or others to whom it may be legally due shall forfeit the same and it shall be finally credited to Authority.

**8.17.4** On no account the final payment shall be made to the contractor before production of clearance certificate of taxes and proof of submission of Income Tax returns. The contractor shall produce document of remittance of GST before final payment. The Taxes as per prevailing rate shall be deducted from the Contractor's bill. Tenderers are however advised to collect necessary clarifications from the authorities concerned for ensuring the extent of various taxes applicable to the work before quoting their rate.

**8.17.5** The release of amounts shall not be made if there is litigation with the contractor.

## **8.18 PAYMENT FOR EXTRA ITEMS**

Over and above the scope of the work, the agreement executing authority shall order, in writing, to the contractor to do any extra items of work and the contractor shall be bound to comply with such orders of the Agreement Executing officer. The Authority shall pay the contractor for such extra items of work at the departmental rates prevailing at the time of the execution of original agreement. If there is no departmental rate, prescribed for such extra items of work, the rate payable to the contractor for the particular items shall be the market value of the materials plus the cost of labour actually engaged for the extra items for the work at departmental schedule of rate plus the contractor's profit of 10%.

## **8.19 (A) PAYMENTS WHEN ALTERATIONS ARE INVOLVED**

No authorized variation shall vitiate the contract. The Authority shall have the right to make any alteration in the original project proposal/designs during the progress of the work and the contractor shall be bound to carry them out. The amount agreed to for the work shall be varied by adding to or deducting there from as the case may be, the value of all authorized alterations, additions, or omissions, the valuation being made on the same basis as for the extra items.

## **8.19 (B) Variation in quantity:**

When there is variation in tender quantity, the rate quoted in form BOQ shall be for the specific quantity as per the NIT and scope of work. However, this quantity may increase or decrease by a maximum extent of 25%. In case of the quantity increase, the contractor will be paid at the rate as given in the accepted BOQ schedule. In case of the quantity decrease, the quantity of pipe not laid thereby (i.e. the difference between the scheduled quantity and actual quantity) shall not be taken into consideration and payment will be made only for actual quantity used at site.

## **8.20. PRICE ESCALATION**

This contract does not have provision for price escalation under any circumstances except in the case of variation in statutory taxes and levies as noted in Clause 7. 9.3. Even if extension of time of completion has been granted under this contract, under any relevant provision, no escalation in price shall be admissible.

## **8.21. NO CLAIMS ON ACCOUNT OF FLUCTUATION OF RATES, IDLING OF LABOUR ETC.**

**8.21.1** No claim shall be entertained on account of fluctuation of rates of labour and materials, railway freight, income tax etc. at any stage.

**8.21.2** No claim for idle labour, due to non -supply of materials by the Authority or for any other reason shall be entertained.

## **8.22. TESTING OF COMPLETED WORK**

All tests necessary to ensure that the structure, equipment, pipe lines and fittings which form part of the work, comply with the specifications, shall be carried out at the site at the contractor's cost. First 200m laid will be tested first in order to check the quality of pipes and work executed. After that testing can be done as per the instruction of Kerala Rural water Supply and Sanitation Agency officials. Such tests shall be carried out within one month of the completion of the work and shall satisfy the requirements included under the Technical Specifications. If the completed work or any portion thereof is found to be defective before the works executed by the contractor are taken over by the Authority, the Regional project Director will give the contractor a notice in writing setting forth the particulars of such defects, and the contractor shall forthwith make the defective part, good or replace the same for satisfying the requirements of the contract. Should he fail to do so within the time specified by the Regional project Director, the Regional project Director may make good the defective part or

replace the same at the cost of the Contractor and such replacement shall be carried out by the Regional project Director to the same specifications as in the contract. In the event of contractor refusing to comply with the instructions of the Regional project Director within the specified period, the contractor is liable to be penalized as per clause 8.10 above.

### **8.23 GUARANTY PERIOD**

**8.23.1** The guarantee period for the work is 12 months after successful completion, testing, trial running and commissioning of the work.

**8.23.2** If it becomes necessary for the contractor to replace or renew any defective portion of the work, the provision of this clause shall apply to the portion of the work so replaced or renewed until the expiration of 12 months from the date of such replacement or renewal or 12 months from the date of completion whichever is earlier. If the defects are not remedied within the notified time, the Regional project Director may proceed to do the work at the contractor's risk and expense, but without prejudice to any other right, which the Regional project Director may have against the contractor in respect of such defects. Until the final certificate of having completed the warranty period successfully has been issued, the contractor shall have the right of entry at his own risk and expenses by himself or duly authorized representatives whose names shall have previously been communicated in writing to the Regional project Director, at all reasonable working hours for the purpose of inspecting the work and taking notes there from and if he desires, at his own risk and expense, making any tests, subject to the approval of the Regional project Director.

**8.23.3** Any defects noticed during the warranty period shall be properly rectified to the satisfaction of the Authority by the contractor at his own risk and cost.

### **8.24 MAINTENANCE PERIOD AND TRAINING OF THE OPERATIONS**

After the completion of the work and issue of completion certificate by the Engineer in charge, the system shall be run, operated and maintained by the contractor for a period of 12 months. The satisfactory and efficient functioning of all the components installed by the contractor for this project should be conclusively proved to the satisfaction of the Regional Project Director. The contractor shall also train the Authority staff during the period of maintenance in running and maintaining the system independently and in an efficient manner i.e. during the 12 months maintenance period the Authority staff and contractors personnel shall be simultaneously engaged in the operation of the system.

### **8.25 EXTENSION OF TIME OF CONTRACT**

Time is considered as the essence of this contract. Any delay due to exceptionally adverse climate conditions or other special circumstances of any kind other than default on the part of the contractor shall fairly entitle the contractor for consideration of extension of time of completion for the work without any extra claim. However, such extension shall be at the sole discretion of the employer and without prejudice to the rights of the Authority to terminate the contract treating time as the essence of the contract. The Authority is not bound to take into account any extra ordinary circumstances unless the contractor has submitted full and detailed particulars within 15 days of the incident, which affected the progress of the work. Further, any such extension granted shall not relieve the contractor from the interest on the advance, if any, drawn by him. Nor shall he be eligible for the incentive for earlier completion of the works during the extended period. All other conditions are as per G.O (P) No.84/97/PW&T dtd 19.8.97)

## **8.26. HANDING OVER OF WORK AND CLEARANCE OF SITE**

The maintenance period shall start after successful completion and commissioning and the handing over shall be after one year of operation and maintenance period.

**8.26.1** The contractor shall hand over all works executed under the contract to the Authority complete in all respects and to the satisfaction of the Regional Project Director at the end of satisfactory completion of the maintenance period.

**8.26.2** The Regional Project Director shall determine the date on which the work shall be regarded as having been completed as contemplated in sub clause above and shall, in support of his determination, grant a certificate to the contractor on an application being so made to him, that the work was duly executed and completed in all respects, on a date to be specified in the certificate and such certificate shall for all purposes be deemed to be the conclusive proof of the date on which the work was so completed. The Regional project Director shall also from time to time determine the date on which any particular stage of the work shall have been completed and shall, on application, grant a similar certificate to the contractor who shall be bound to follow all such determination in all subsequent dealings with the Authority on the subject matter of the contract in regard to the work.

**8.26.3** On completion of the contract, the contractor shall clear away and remove from the site all construction plant, surplus material, rubbish, debris and all temporary works of every kind and leave whole of this' site and work in a neat and clean condition to the satisfaction of the Regional Project Director. No final payment in settlement of the account of the work shall be made to the contractor until, in addition to any other condition necessary for such final payment, the site clearance shall have been effected by him, and in the event of the failure of the contractor to comply with the provision of this Sub Clause within 7 days after receipt by' him of a notice to that effect, such clearance may be made by the Regional Project Director at the expense of the contractor and in all such cases the Authority shall not, in any way be liable for any loss or damage to any property of the contractor left at the site caused by such removal, there from and such removal may without prejudice to any other mode of removal be effected by means of public sale of such materials and property or by such other means as may be deemed fit and convenient to the Regional Project Director.

**8.26.4** Deleted

## **8.27. SETTLEMENT, ARBITRATION OF DISPUTES AND NON APPLICABILITY OF ARBITRATION**

**8.27.1** Settlement of disputes by Arbitration shall not be applicable to this contract.

**8.27.2** In the case of any disputes arising between the parties to this contract on any of .the matters covered under this contract, the same shall be settled solely by a competent court having jurisdiction within the State of Kerala, and by no other Court.

**The Regional Project Director**

# KERALA RURAL WATER SUPPLY AND SANITATION AGENCY

## 1. TENDER CONDITIONS: P ART – III

### CONTRACT CONDITIONS

#### 9.1 LAW GOVERNING THE CONTRACT

- 9.1.1** All contracts or terms thereof entered into between the Authority and the contractor under these conditions of contract shall be governed and regulated in general by the relevant laws in force in the territory of India relating to contracts.
- 9.1.2** The contractor shall strictly conform to the provisions, for the time being in force, of any laws relating to works or any regulations and bye-laws made by any local authority or any water and lighting companies or any undertakings within the limits of the jurisdiction of which it is proposed to execute the work or to obtain connection with their systems or undertakings for the purpose of such work, and where the contractor considers that variations in the drawings or specifications of such work are necessary to enable him to comply with the provisions of the law or regulations or bye-laws, as aforesaid, he shall give to the Agreement Executing Authority and the Regional Project Director a notice in writing specifying the variations, and no action in this behalf shall be taken by the contractor until he receives instruction in writing from the Regional project Director in respect thereof. The Contractor shall be bound to give to the authorities concerned such notices as may be provided in the law, regulations or bye-laws as aforesaid, and to apply all fees and taxes payable to such authorities in respect thereof.

#### 9.2 COMMENCEMENT OF WORK

- 9.2.1** The contractor shall commence the work within 20 days after the receipt, by him, of an order in writing to this effect from the tendering authority and shall proceed with the same with due expedition and without delay, except as may be expressly sanctioned or ordered by the tendering authority or be wholly beyond the contractors' control. If the contractor fails to start work within the time specified by Kerala Rural Water Supply and Sanitation Agency after signing the agreement or fails to maintain the specified rate of progress, the security deposit shall be forfeited to Kerala Rural Water Supply and Sanitation Agency and the matter will be disposed of suitably by the Authority. If such measure results in any loss to Authority, such loss shall be recovered from the contractor as arrears or revenue but should it be a savings to the Authority, the original contractor shall have no claim whatsoever to the difference. Recoveries on this or any other amount will be made from the sum that is already due or may become due to the contractor on this or any other existing contracts or under the Revenue Recovery Act, or otherwise as the Authority may decide.
- 9.2.2** It shall be the joint responsibility of KRWSA and the contractor to get appropriate sanction from the related authority.

#### 9.3 OCCUPATION OF LAND

No land belonging to or in possession of the Authority shall be occupied by the contractor without the permission of the Authority. The contractor shall not use or permit to use such land occupied by him for the purpose other than the execution of the works.

#### 9.4 WATER, POWER AND APPROACH ROAD

The contractor shall, at his own cost, make arrangements for obtaining supply of water and power necessary for the work.

- 9.4.1** The contractor must arrange his own supply of water at his own expense, for the whole execution of the work



- 9.4.2** The Authority shall render necessary assistance to the contractor for obtaining the power connection, but the expenses for such connections and Electrical Energy charges shall be borne by the contractor.
- 9.4.3** For testing of pipelines and water retaining structures during the progress of work, the contractor must arrange his own supply of water.
- 9.4.4** The Authority does not undertake to construct or make available any approach road or other means of approach to the proposed work site and the tenderer shall get acquainted with the available means of approaches to the proposed site and quote for the various items. The Authority shall not be liable for any claim raised later, on the plea of non – availability or non-access to the site.

## **9.5 TEMPORARY SHEDS AT WORKSITE**

- 9.5.1** The contractor shall at his own expense, provide himself with site office sheds, store ho use and yard in such situations and in such number as is requisite, in the opinion of the Regional project Director, for efficiently carrying out the work and the contractor shall keep at each of such sheds, store houses and yards, sufficient quantity of materials and plant in stock so as not to delay the carrying out of the work with due expedition and the Regional project Director and his assistant shall have at all reasonable times, free access to the said sheds, store houses and yards for the purpose of inspecting the stock of materials and plant stored therein, and any materials or plant objected to by the Regional Project Director shall be forthwith removed from the shed, store house or yards by the contractor. The contractor shall at his own expense provide and maintain suitable arrangements and equipment as may be deemed necessary by the Authority for the proper execution of the work.
- 9.5.2** When temporary sheds, stores etc. Put up by the contractor are no longer required in the opinion of the Authority, the contractor shall remove them at his own expense and in such manner as the Regional Project Director may direct. In the event of any failure on the part of the contractor to remove any such temporary work, the Regional Project Director shall cause the same to be removed and all the costs of such removal including the cost of supervision and other incidental charges shall be recovered from the contractor.
- 9.5.3** If temporary huts provided by the contractor on the land of the Authority for the accommodation of labour engaged by him in connection with the work are no longer required after the completion of the work, it shall be the duty of the contractor to hand over to the Authority vacant possession of the said land, and if the contractors labour refused to vacate and has to be evicted by the Authority, all expenses incurred by the Authority in connection therewith shall be met by the contractor or be recovered from him.

## **9.6 SETTING OUT**

- 9.6.1** The contractor shall be responsible for the true and proper setting out of the works and for the correctness of the position, levels, dimensions and alignments of all parts of the work and for the provision of all necessary instruments, appliances and labour in connection therewith. If at any time during the progress of the work, any error shall app ear or arise in the position, levels, dimensions or alignments of any part of the work, the contractor on being required to do so by the Regional Project Director shall at his own expense rectify such error to the satisfaction of the Regional Project Director. The checking up of any setting out or any line or level by the Regional Project Director or his assistant shall not in any way relieve the contractor of his responsibility for the correctness thereof and the contractor shall carefully protect and preserve all bench marks, site and rails, pegs etc. used in setting out the work.

**9.6.2** The contractor shall keep at his own cost all portions of work free from water or dampness due to spring, seepage or inclement weather and in a neat and sanitary condition.

## **9.7. EXECUTION OF WORK**

**9.7.1** The decision of the Regional Project Director shall be final, conclusive and binding on all questions relating to the meaning of drawings and specifications and to the quality, workmanship and materials used on the work.

**9.7.2** The whole of the work shall be executed in perfect conformity with the specifications and drawings of the work approved by the Authority. If the contractor performs work in a manner contrary, to the specifications and drawings or any of them, he shall bear all costs arising or ensuing there from and shall also be liable to the Authority for any loss.

**9.7.3** The whole of the work specified and provided for in the contract or that may be necessary to be done in order to form and complete any part thereof shall be executed in the best and most substantial workman like manner with materials of the best and approved quality of their respective kinds, according to the particulars contained in or implied by the specifications and as referred to in any additional particular instructions and drawings as may be found requisite to be given during the execution of the work and to the entire satisfaction of the Regional Project Director.

## **9.8. WORK DURING NIGHT AND SUNDAYS AND HOLIDAYS**

**9.8.1** The contractor shall not carry out any work between the hours of sunset and sunrise without the previous permission of the Regional Project Director or his assistant in writing.

**9.8.2** No work shall be done on Sundays and holidays without the permission of the Regional Project Director or his assistant.

**9.8.3** However, when work is unavoidable or necessary for the safety of life, property or works, the contractor shall take necessary action forthwith and report to the Regional Project Director immediately.

## **9.9 FACILITIES OF INSPECTION**

**9.9.1** The contractor shall afford the Officers of Kerala Rural Water Supply and Sanitation Agency every facility for entering in and upon any portion of the work at all hours for inspection or for any other purpose and shall provide all labour, materials, planks, ladders, pumps, appliances and things of every kind required for the purposes aforesaid and the Director Technical or his assistant shall at all the times have access, free of cost, to every part of the work and to all places at which materials for the work are stored or being prepared.

**9.9.2** The contractor shall give at least seven days notice in writing to the Regional Project Director and his Assistant whenever any work or materials are intended to be covered up in the earth in bodies or walls or otherwise to be placed beyond the reach of measurements so that the work may be inspected or the correct dimensions thereof may be taken before the work is so covered or placed beyond the reach of measurement and where the contractor defaults to give such notice the same shall at the opinion of the Regional project Director or his assistant be uncovered and measured at the expenses of the contractor or in the alternative, no payments shall be made for such work or materials.

**9.9.3** Should the Director Technical or any other Engineer / Supervisor authorized in writing by him to supervise the work, at times, consider it necessary for the purpose of enabling him to make any inspection or tests or analysis or to verify or ascertain the quality or strength of any part of the

work or of any materials the contractor shall if and when so required to do by the Regional Project Director or the person authorized as aforesaid, open up the work or the materials for inspection or testing or analysis, or pull down, or pull out the work into any number of parts and make such openings into, under or through any part of the work, as may be directed and provide all things which in the opinion of the Regional project Director or the person authorized as aforesaid, may find necessary to enable the inspection or tests or analysis of the work or any part thereof or of the materials or workmanship to be made and the contractor shall close up, cover, re-build, and make good the whole at his own cost, as and when directed by, and to the satisfaction of the Regional project Director, provided always that the work, in the opinion of the Regional project Director is found to be satisfactory and in accordance with the contract, the expenses incurred by the contractor for such examination, inspection or test shall, upon a certificate in this behalf by the Regional Project Director, be borne by the Authority.

#### **9.10 SUSPENSION OF WORK**

- 9.10.1** The contractor shall not suspend any work without the prior written permission of the Regional project Director in charge of the work under any circumstances. Any such suspended work shall be treated as incomplete and abandoned by the contractor and the Authority shall have the right to get such works completed through any other manner at the risk and cost of the contractor.
- 9.10.2** The contractor shall, on an order issued by the Regional Project Director that for any reason the work shall not be commenced or shall be suspended or stopped before completion, the contractor shall be paid for the work actually done and materials actually supplied up to the date of stoppage but the Authority shall be held in no way responsible for any further liability.

#### **9.11 ALTERATION IN THE WORK TO BE AUTHORISED**

- 9.11.1** No alteration in, or additions to, or omissions from or abandonment of any part of the work shall be deemed to be duly authorized except under written instructions from the Regional Project Director and it shall be the duty of the contractor to obtain in time such written instructions in every case.
- 9.11.2** If any work over and above that in the contract is required to be executed at the site the contractor shall have no right to be entrusted with the execution of the work and the same may be carried out through another contractor or contractors or by other means at the discretion of the Authority.
- 9.11.3** The Regional Project Director shall have full powers to send persons upon the premises to execute fittings, other works etc., not included in the contract for whose operations the contractor shall afford every reasonable facility during ordinary working hours, provided that such operations shall be carried out in such a manner as not to impede the progress of the work, included in the contract, but the contractor shall not be responsible for any damage which may happen to or be occasioned by any such fittings or other works, provided that he complies with the Regional Project Director's instructions in connection there with and provided that the damage is not caused by himself or his employees. The contractor shall, at all times, cooperate, assist, attend on, and afford facilities for such specialists, as may be employed by the Regional Project Director or other works, in connection with the work. The contractor shall also cause such special work or protect it as instructed to avoid injury during progress of the work. For failure, so to protect, the contractor must make good any damage caused. If any part of his work depends for proper execution upon or results from the work of the other contractor, the former shall inspect and promptly report to the Regional Project Director any defect in the work of the latter

likely to render it unsuitable for proper execution and results. The failure of the contractor entrusted with the work so to inspect and report shall, for all purposes be deemed to constitute an affirmative approval of the work of the other contractors as being fit and proper for the receipt of his work, except as to defects which may develop in the work of the latter contracts after the execution of his work.

## **9.12 PRECAUTIONS DURING PROGRESS OF WORK**

- 9.12.1** The contractor shall be responsible to see that the levels, profiles, bench marks, masonry pillars or other marks set up by the Authority for guidance in the execution of the work are not disturbed, removed or destroyed and if any such marks as in the opinion of the Regional Project Director or his assistant, found disturbed, removed or destroyed, they will be replaced by the Authority at the cost of the contractor.
- 9.12.2** During the execution of the work, the contractor shall at his own cost provide adequate materials for all works relating to shoring, timbering, strutting, scaffolding etc. and execute the same in such a way as to ensure, in abundant measure, the stability and safety of all structures, excavations and works and further ensure that no physical injury or harm is likely to be caused to any person or no damage or loss is caused to any property. When two or more contractors are engaged on work in the same vicinity, they shall work together in a spirit of co-operation and accommodation. The contractor shall not take or cause to be taken any steps or action that may cause disruptions, discontent or disturbance to the works, labour and arrangement of other contractors in the neighboring or other project localities. In case of any difficulties amongst the contractors, the Regional Project Director shall conduct his work so far as it affects the others.
- 9.12.3** Existing roads or water courses shall not be blocked, cut through, altered, save to the extent permitted by the Regional Project Director. All compensation claimed by the authorities concerned for any unauthorized closure, cutting through, alteration, diversion or obstruction to such roads or water courses by the contractor be deducted from any sums which is due to or may become due to him in terms of the contract, or otherwise according to law.
- 9.12.4** The contractor shall be responsible for taking all precautions to ensure the safety of the public, whether on the property belonging to the Authority or others and shall post such look-out men, as may in the opinion of the Regional Project Director, be required to comply with the regulations pertaining to the work.
- 9.12.5** The contractor shall be responsible for safety arrangement of all equipment used for construction and shall employ trained workmen conversant with the safety regulations. The contractor shall employ only tested equipment and tools for safety and shall periodically repair them to the satisfaction of the Regional Project Director. All test certificates shall be made available to the Regional Project Director. If at any time, in the opinion of the Regional Project Director or his assistant, this provision is not complied with the contractor shall forthwith replace equipment and tools.
- 9.12.6** The contractor shall display notices and arrange for proper fencing at such places where hazardous work is being carried out. The contractor shall provide at his own expense on the work to the satisfaction of the Regional Project Director proper and sufficient firefighting equipment, first aid appliances etc. which shall at all times be available for use.
- 9.12.7** The contractor shall at all times comply with all rules and regulations made by the Government, local bodies and such directions as may be issued by the Authority from time to

time in regard to safety, first aid and health measures. The contractor shall be legally and financially liable for any lapse in taking precaution during execution of works.

### **9.13. PROCEDURE TO RECTIFY DEFECTIVE WORKS**

- 9.13.1** If it shall appear to the Regional Project Director or his assistant, at any time during the progress of the work or at any time prior to the expiration of the guarantee period of the work, that any work has been executed with unsound, imperfect or unskilled workmanship or with materials of inferior description, or that any materials or articles provided by the contractor for the execution of the work are unsound or of a quality inferior to that contracted for, or otherwise not in accordance with the contract, the contractor shall, on demanding in writing by the director Technical or his assistant to specify the work, materials or articles, complained of and within the period of time mentioned in the demand, pull down, take up, or take out the work so complained of or objected to, remove from the site or separate from other materials or sort out the materials or articles or part thereof shall have been included any (on account) payment to the contractor, the same shall be taken in to account and deducted from any subsequent payment due to the contractor. The contractor shall also remove from the work and site any equipment fixed or otherwise objected to by the Regional Project Director or his assistant or any other persons authorized in writing by him.
- 9.13.2** The contractor shall forthwith rectify or remove and reconstruct the works so specified either in whole or in part, as the case may require, or as the case may be, and provide proper and suitable materials or articles for material or articles complained of or objected to. If the contractor fail to remedy any defect within the period specified in demand mentioned in sub clause above and in the manner required, or if he shall fail to remove from the site any materials or articles condemned as unsound or otherwise not in accordance with the specifications or to substitute suitable articles for the materials complained of or objected to, the Regional Project Director or his assistant may cause such work to be carried out and such material s or other articles to be replaced b y such means as he think fit, and all expenses consequent thereon, or incidental thereto, auxiliary thereof, shall be met by the contractor and borne by him and shall be recoverable from him by the Authority or may be deducted by the Regional Project Director from any moneys due or that m ay thereafter become due to the contractor.
- 9.13.3** Should the Regional Project Director consider that the work, although not executed in strict accordance with the specifications may be allowed to stand, payment for the same shall be made at such reduced rate as may be fixed but this procedure is quite optional on his part and shall have the concurrence of the Director technical.
- 9.13.4** In case of quality of work done is found to be poor, contractor will be liable to compensate for cost of rectification/replacement, and shall be blacklisted from participating in future tenders

### **9.14 SUPPLY & TESTING OF MATERIALS**

- 9.14.1** The Contractor shall supply all the materials including pump sets, compressors, electrical panel boards, electrical and wiring materials, pipes and specials covered under the contract at his own cost. The pipes, specials, pumps etc. should be tested at the factory/site as per prevailing KRWSA project norms. Also ISI/ISO marked materials should alone be accepted, wherever ISI/ISO specifications are available for such item. Qualified officers/Agency engaged by Regional Project Director according to KRWSA norms will be engaged for pre delivery inspection of materials conducted at the manufacturing unit.

- 9.14.1.1 All materials shall be supplied by the contractor in a phased manner as per the phased supply schedule prepared by the agreement executing authority if asked. Quantity and time of each supply shall be specifically mentioned in this schedule in tune with the time of completion.
- 9.14.1.2 Schedule for phased supply of pipes and specials shall be prepared by the agreement executing authority based on the following criteria:
- a) Targeted progress of pipe laying works
  - b) Availability of permission from other agencies (PWD, NH, NHAI, KSTP, KRFB, Corporation, Panchayath, etc.) for laying pipes
- 9.14.1.3 Each supply of material shall be done by the Contractor only after getting written instruction from the Engineer in charge concerned.
- 9.14.1.4 The Regional Project Director in - charge shall direct the Contractor to place supply order in each phase after evaluating actual progress of laying of pipes supplied in the previous phase.
- 9.14.1.5 Agreement executing authority shall have the authority to modify the schedule for phased supply of remaining materials during the progress of work, if there is variation from the targeted progress.
- 9.14.1.6 On each supply, Contractor may submit bills for materials supplied not exceeding 80% of estimate rate /quoted rate of materials, whichever is less.

**9.14.2** Before using any material for the work, the contractor at his own cost, shall submit to the Regional Project Director for his approval such samples of materials as are proposed to be used. The materials shall strictly conform to the specifications approved by the Authority. Notwithstanding anything contained in this clause, the contractor shall be held fully responsible for the quality and soundness of all the materials and machinery that are supplied by him for execution of the work and completion of the project and the Regional Project Director's approval and inspection by third party inspection agency before delivery shall not in any way absolve him of his responsibility in this matter.

**9.14.3** The contractor shall test or obtain the approved analysis of or weigh all materials required by the specification to be tested or analyzed or weighed where so required by the Regional Project Director and shall, if any when so required to do, test the whole or each part of the work or the materials in such manner at such times and such place or places, whether before or by the specifications or as may be directed by any of the persons aforesaid.

**9.14.4** The contractor shall, if and when so required by the Regional Project Director to do, prepare and /or submit samples of works and materials for the approval of the Regional Project Director such samples shall be retained by the Regional Project Director and no materials which are required to be tested or analyzed or weighed or of which samples have to be submitted, shall be used in the work, until tests, analysis, weights or samples as the case may be shall have been approved in writing by the Regional Project Director.

**9.14.5** All materials for the work must comply with the requirements or specifications laid down in the tender form and must satisfy the tests and / or analysis laid down in the specifications of the Bureau of Indian Standards/International Standards Organization or such other recognized specifications as the Regional Project Director may direct as being equivalent thereto, and in either case, with such additional tests and I or analysis as the Regional Project Director may order or in the absence of such standards or specifications, with such requirements, tests and analysis as in the opinion of the Regional Project Director, are fair and suitable.

## **9.15 TOOLS AND PLANT SUPPLIED BY AUTHORITY**

- 9.15.1** It shall be the duty of the contractor to provide adequate tools and equipment needed to do the work efficiently and expeditiously.
- 9.15.2** No extension of time will be granted for delay in the procurement of construction equipment and / or spare parts by the contractor.
- 9.15.4** The contractor shall take responsible care of all tools and plant belonging to him and the Authority shall not be liable for any damage or loss caused at the time of work.

## **9.16 SUBLETTING OF CONTRACT**

The contractor shall not at any time assign, sublet his contract or any part thereof to any person or allow such person to become in any way interested therein in any manner what so ever without the prior permission in writing of the Regional Project Director in charge of the work. Any contravention of this condition shall entitle the Authority to rescind the contract and shall also tender the contractor liable for payment to the Authority in respect of any loss or damage arising out of or ensuing from such recession of the contract. Provided further that where the subletting of the work by the contractor, in any case, is permitted' by the Authority, the contractor shall not, at any time, be absolved of any obligation or responsibility under the contract or any part thereof and shall continue to be responsible for all acts or omission and commissions of the sub contract, his agents, servants or workmen as fully and effectually as if the same were acts of omissions and commissions of the contractor, his agents, servants or workmen, as the case may be.

## **9.17 CONTRACTOR'S AGENT:**

- 9.17.1** The contractor shall, when he is not personally present at the site of the work invariably place and keep at such site a properly qualified agent, duly authorized and empowered to act on his behalf and to receive on his behalf the orders and instructions required or permitted under the contract to be given to the contractor by the Regional Project Director or his subordinates to supervise the work. All such orders and instructions given to, and all acts done by agents shall be binding on the contractor as if such orders and instructions were given to him or, such acts had been done by him.
- 9.17.2** Before absenting himself, the contractor shall furnish the name, the designation and the address of the Agent.
- 9.17.3** Prior to the appointment of such agent, the contractor shall submit to the Regional Project Director the name and other relevant details of the person intended to be appointed as his agent and no appointment shall be made until the Regional Project Director has approved the same and notified his approval in writing to the contractor and whenever the contractor desires to change his agent the same procedure as for the appointment of a new or fresh agent shall be followed.
- 9.17.4** From the moment the agent so approved and appointed takes charge of the work, he shall be held to be fully authorized and empowered to present and act for and on behalf of the contractor for all or any of the purpose of the contract, and notwithstanding the absence of any formal authority or definite' instructions from the Contractor to the said agent or any defects therein, or the imposition of any restrictions or limitations on the power or authority of such agent by the contractor, nothing whatsoever shall in any way affect, qualify or limit the full authority or power of such agent, or absolve the contractor of his liabilities or obligations under the contract.
- 9.17.5** The contractor shall forthwith remove from the site and works and not to re – employ without the written permission of the Regional Project Director, obtained in his behalf, any agent whose

removal the Regional Project Director have asked for in writing, or any assistant whom he may consider incompetent or is sufficiently qualified or to have been guilty of misconduct or negligence and whose removal the Regional Project Director may have asked for in writing.

#### **9.18 SUPERVISORY STAFF OF THE CONTRACTOR**

- 9.18.1** The contractor shall not employ any person who was in the service of the Authority or the Government without definite written sanction of the Authority. The staff employed at the site by the contractor shall be the same as he has agreed for in the relevant format included in this tender document. Any change from the same shall have proper written acceptance of the Regional Project Director.
- 9.18.2** The contractor shall at all times place and keep on the work an adequate number of efficient and competent staff to give necessary directions to his workmen in the execution of the work and to see that the workmen execute the work in a sound and proper manner and shall employ only such supervisors, workmen and laborers in or about the execution of the work, as are careful and skilled in their various trades and callings.
- 9.18.3** The contractor shall forthwith remove from the work any supervisor, workmen or laborer objected to by the Regional Project Director, and if and whenever so required by the Regional Project Director the contractor shall submit the correct return showing the name of all staff and workmen employed by him or about the work.
- 9.18.4** If, in the opinion of the Regional Project Director, the contractor is not employing on the work such number of staff and workmen as is reasonably necessary for the, proper completion of the work within the time prescribed he shall forthwith communicate his opinion in writing to the contractor, and the contractor shall within seven days of the receipt of the said communication, employ such additional staff and labour as may be required by the Regional Project Director and any failure on the part of the contractor to comply with such instructions shall entitle the Authority to rescind the contract.
- 9.18.5** The contractor shall engage not less than one Engineering Graduate and one Engineering Diploma holder at the work site at his cost and any failure in this regard will be treated as breach of contract and shall entitle the Authority to penalize the contractor/rescind the contract.

#### **9.19 DAMAGES PAYABLE BY THE CONTRACTOR**

##### **9.19.1 DAMAGE TO PROPERTY AND PERSON**

1. The contractor shall, at his own expenses and to the satisfaction of the Regional project Director, reinstate and make good or be liable for any compensation for any injury, loss or damage occasioned to any property or right whatsoever, including the property and right of the Authority, servants or employees of the Authority, being injury, loss or damage arising out of or in any way connected with, the execution or purported execution of the contract, and further the contractor shall indemnify the Authority, private person, in respect of any such injury including, any injury resulting in death or disability to person or property, including all claims which may arise under the Workmen's Compensation Act, or under any other law for the time being in force or otherwise.
2. The contractor shall (except if and so far as the specifications otherwise provide) indemnify and keep indemnified the Regional Project Director for all losses and claims for injuries or damages to any person or property whatsoever including surface or other damage to land being or crops being on the side suffered by tenants and occupiers which may arise out or in consequence



of the construction and maintenance of the works and against all claim, demands, proceedings, damages, costs charges and expense whatsoever in respect thereof or in relation thereto, provided always that nothing therein contained shall be deemed to render the contractor liable for or in respect of or to indemnify the Authority against any compensation or damages for or with respect to

- a. The permanent use or occupation of the land by the work or any part thereof (save in respect of damage to crop as aforesaid).
  - b. The right of the authority to construct the work or any part thereof on, over, under in or throughout the land.
  - c. Interference whether temporary or perm anent with any right of light, airway or water or other easement or quasi-easement which is the unavoidable result of the construction of the work in accordance with the contract.
  - d. Injuries or damages to person or property resulting from any act or neglect done or committed during the currency of contract by the Authority /Departmental officers, servants or other contractors (not being employed by the contractor) or in respect of any claim demand, proceedings, damage, cost, charges and expenses in respect thereof or in relation thereto.
3. If compensation has to be paid to court attachment or judgment etc. due to damage of person or property, such amount will be recovered from the contractor / tenderer.
  4. The contractor shall insure all the employees employed in the work site as per rules against any accidents and further claim. KRWSA will not be responsible for any such accidents/claims of employees of the contractor.

#### **9.19.2 METHOD OF RECOVERY**

1. Damages payable by the contractor under the terms of the contract may be deducted by the Regional Project Director from part of his security deposit or from any other sums due, or which may become due to him from the Authority or through revenue recovery proceedings.
2. In every case in which under any clause or clauses of this contract, the contractor shall have rendered himself liable to damages amounting to the whole of his security deposit, the Regional project Director shall have powers to rescind the contract altogether and to have the work completed without further notice, at the contractor's risk or expense as the Agreement Authority/ Regional Project Director may deem best suited to the interest of the Authority and the contractor shall have no claim to compensation for any loss that may accrue from any material he may have collected or engagements he may have entered into, on account of the work and the Regional Project Director shall have powers to deduct whatever amount may be expended on the completion of the work, from any sums that may be due or become due from the Authority to the contractor on account of this or any other work or recover such sums from him and his assets, movable and immovable under the provision of the Revenue Recovery Act for the time being in force, as if they were arrears of land Revenue or otherwise as the Authority may choose. And in case the contract shall be rescinded under the provision afore said, the contractor shall not be entitled to recover or be paid any sum of any work actually performed under this contract unless and until the Regional Project Director shall have certified the performance of such work and the value thereof and he shall only be entitled to be paid the value so certified.
3. In the event of the Regional Project Director 's putting in force the powers vested on him under the preceding clause, he may, if he so requires it, take possession of all tools, plant, materials and stores or any portion thereof, on the place where the works were to be performed or on other land

of the Authority adjoining thereto, paying or allowing for the same in account, at the contract rates, or if not specially provided for therein at current market rates, otherwise the contractor may be required to remove such tools, plant and materials or stores from the premises, and in the event of his failing to do so, the Regional Project Director may remove them at the contractors expense or sell them by auction on account of the contractor. The Regional Project Director may devote all, or such portion as may be requisite, any guarantee or reserve fund or any moneys due to or become due to the contractor for this or any other work to make good, bad or indifferent work, on the part of the contractor in such manner as he may think desirable.

4. If it shall appear to the Regional Project Director or his subordinate in charge of the work, that any work has been executed with unsound imperfect or unskilled workmanship, or with materials of an inferior description, the contractor shall on demand in writing forthwith rectify, relay, remove or reconstruct the same in whole or in part, as the case may require, at his own cost, and in the event of his refusing to do so within a period to be specified by the Regional Project Director or his subordinate or if he shall fail to remove, from the site of the work within a specified period any material or article which is considered by the same officers as unsound or of bad quality or not agreeable to the terms of the contract and to provide immediately suitable materials or articles in lieu of these condemned, then the contractor shall be liable to pay damages at the rate of one percent on the amount of the estimate for every day not exceeding ten days that he fails to comply with the written demand of the Regional project Director or his subordinates. And in the event of non – compliance of the written demand even after the lapse of ten days the contract is liable to be terminated at the risk and cost of the contractor without further notice.
5. All compensations or other sums of money payable by the contractor to the Authority under the terms of this contract with the Authority or under any other contract with the Authority, shall without prejudice to any other mode of recovery, be recoverable from the contractor by way of deduction or payment, out of the sale proceed of a sufficient part of the security deposit held in Government Securities or in National Savings Certificate or out of the interest accrued thereon or out of the said security deposit held in cash or out of any sums which may be due or may subsequently become due, to the contractor from the Authority, on any account what so ever and in the event of the value of his security deposit being reduced by reason of any such deductions the shortage shall be made up by effecting extra recovery from subsequent bills or sales.

## **9.20 RELICS AND EXCAVATED MATERIALS**

**9.20.1** All gold, silver and other materials of any description and all precious stones, coins, treasures, relics, antiquities and other similar things which shall be found in or upon the site shall be the property of the Government and the contractor shall duly preserve the same to the satisfaction of the Authority and shall, from time to time, deliver the same to such person or persons as the Authority may appoint to receive the same.

**9.20.2** The contractor shall not sell, or otherwise dispose of or remove, any sand, stone, clay, ballast, earth, rock or other substances or materials which may be obtained from any excavation made in or upon the site, or any building or produce standing upon the site at the time of obtaining the delivery or possession thereof and all such substances, materials, buildings and produce shall be and shall continue to be the property of the Authority provided that the contractor may, with the permission of the Regional Project Director use the same for the work at such cost as may be determined by the Regional Project Director.

## **9.21 REPORTING OF ACCIDENT**

The contractor shall be responsible for the safety of all employees or workmen employed or engaged by him on and in connection with the work and shall forthwith report to the Regional project Director or his assistant all cases of serious accidents/injuries to any of them, however caused and whatever occurring on the work and shall make adequate arrangements for rendering all possible aids to the victims of the accidents.

## **9.22 WORKMEN'S COMPENSATION ACT**

In every case in which, by virtue of the provisions of Sub Section (1) of Section 12 of the Workmen's Compensation Act 1923, if the Authority is obliged to pay any compensation to a workman employed by the contractor in the execution of the work, Authority shall recover from the contractor the amount of the compensation so paid and, without prejudice to the rights of the employer under Sub Section (2) of Section 12 of the said Act, the Authority shall be at liberty to recover such amount or any part thereof by deducting it from the security deposit or from any sum due from the Authority to the contractor, whether under these conditions or otherwise. The Authority shall not be bound to contest any claim made against him under Sub Section (1) of Section 12 of the said Act except on the written request of the contractor and upon his giving to the Authority full security for all the costs for which the Authority may become liable in consequence of contesting such claim.

## **9.23 WAGES TO LABOUR**

**9.23.1** The contractor shall comply with the provisions of the Minimum Wages Act and the rules made there under in respect of all employees or workmen employed or engaged by him on road construction or in building operations or in stone breaking or stone crushing for the purpose of carrying out the contract.

**9.23.2** If, in compliance with the terms of the contract, the contractor supplies any Labour to be used wholly or partly under the direct orders and control of the Authority whether in connection with the work being executed by the contractor or otherwise for purposes of Authority such Labour for the purpose of this clause, be deemed to be persons employed by the contract.

**9.23.3** If any money shall, as a result of any claims or applications made under the said Act, be directed to be paid by the Authority, such moneys shall be deemed to be moneys payable to the Authority by the contractor , and on failure of contractor to repay the Authority any moneys as aforesaid within 7 days after the same shall have been demanded, the Authority shall be entitled to recover the same from any money due to the contractor under the contract or any other contract with the Authority.

**9.23.4** The Authority shall also be entitled to deduct from any money due to the contractor (whether under the contract or any other contract with the Authority) money paid or payable by the Authority by way of any compensation under the said Act or on account of costs or expenses in connection with any claims thereto and the decision of the Regional Project Director on any question arising out of the application of this clause shall be final and binding upon the contractor.

**9.23.5** In respect of all labour directly or indirectly employed, in works for the performance of the contract as part of this agreement, the contractor shall comply with or caused to be complied with all rules framed by the Authority from time to time for the protection of health and sanitary arrangements for the workers employed by the Kerala Rural Water Supply and Sanitation Agency and its contractor.

## **9.24 LABOUR RETURNS**

Monthly labour returns shall be submitted by the contractor to Regional Project Director in the proper forms so as to reach him not later than the first of every month. In addition to the above, the contractor shall also maintain daily and weekly returns of labour employed by him and these shall be made available for verification by the officers of Kerala Rural Water Supply and Sanitation Agency as and when called for.

## **9.25 CONTRACT DOCUMENTS AND MATTERS TO BE TREATED AS CONFIDENTIAL**

All documents correspondences, decisions and orders concerning the contract shall be considered as confidential and / or restricted in nature by the contractors and he shall not divulge or allow access to them by any unauthorized person.

## **9.26 MATERIALS TO BE SUPPLIED**

It shall be the responsibility of the contractor to arrange for materials and the Authority shall not issue any material to the contractor.

## **9.27 CONTRACTOR'S RESPONSIBILITY FOR STORES**

The materials such as Cement, MS Rods, tor steel and other materials including pipes and specials required for the work shall be procured by the contractor and the amount quoted should be inclusive of the cost of cement, steel and all other materials. The cement supplied for use shall be as per ISS 269/1976 and steel as per ISS 1786/1985 with latest amendments, if any. The materials should bear the relevant ISI/ISO certification marks. Before using any material for the work, the contractor, at his own cost, shall submit to the Regional Project Director for his approval such samples of material as are proposed to be used. The materials shall strictly conform to the specifications approved by the Authority. Notwithstanding anything contained in this clause, the contractor shall be held fully responsible for the quality and soundness of all the materials and machinery that are supplied by him for the execution of the work and completion of the project and the Regional Project Director's approval shall not in any way absolve him of his responsibility in this matter. The standard tests as per ISS to ensure the quality of cement, steel and other construction materials shall be got done by the contractor at their cost as per the direction of the officers of Kerala Rural Water Supply and Sanitation Agency to ascertain the quality. The Authority reserves the right to super check the results. If the materials supplied are found to be not passing the tests, the same shall be rejected by the Regional Project Director and the contractor shall be bound to dismantle and remove such constructions already made using such sub standard quality materials if found during the erection of the work and the contractor shall be fully responsible and liable for such losses to the Kerala Rural Water Supply and Sanitation Agency.

## **9.28 MATERIALS AND PLANT AT WORK SITE**

All materials and plants brought by the contractor in or upon the site or on the land occupied by the contractor in connection with the work and intended to be used for the execution thereof shall not be removed from the site of work without the permission of the Regional Project Director.

## **9.29 GENERAL**

All other conditions shall be as in force in the Kerala Rural Water Supply and Sanitation Agency, if it is found relevant to explain any clause of this N.I.T. Otherwise the conditions are strictly independent.

**The Regional Project Director**

## **KERALA RURAL WATER SUPPLY AND SANITATION AGENCY**

### **10. GENERAL TECHNICAL SPECIFICATIONS**

#### **10.1 GENERAL**

**10.1.1** Generally, the specifications of all materials and work pertaining to this contract shall be governed by the relevant Indian Standards and by MDSS. In the absence of Indian Standards, the British Standard Specifications shall be followed. The specifications furnished hereunder are only to enlighten the tenderer on the requirements of Kerala Rural Water Supply and Sanitation Agency and are not intended to be against any other specifications stipulated by BIS or other standards and common practices widely adopted in the country at present. In case of a doubt regarding the specifications, the Engineer in charge will clear the doubts and give final decision based on the written request of the contractor. The decisions intimated in writing shall be binding on the contract work.

**10.1.2** The successful completion of this contract calls for site surveys, investigation, planning, hydraulic and structural design of the components, assessment of capacity/standard of mechanical, electromechanical and electrical items to be procured, preparation of procurement schedule, preparation of implementation schedule etc. The tenderer shall see that he always sticks on to conservative designs based on time tested and well accepted practices as per the guidelines and norms prescribed by BIS, CPHEEO or such other institutions.

#### **10.1.3. REPORTS, DESIGNS AND DRAWINGS**

1. Deleted

#### **10.1.4 ECO -FRIENDLY SYSTEM OFFER**

The system offered and as completed shall be environment friendly and shall not affect /alter the environment beyond any permissible limits stipulated by concerned institutions.

#### **10.1.5 MAN MADE STRUCTURES, OTHER UTILITIES - AFFECTING THE WORK**

1. When the works under this contract are executed situations may arise when the works are affected by other manmade structures either in service or abandoned. It is also likely that other utility services installed by various Government bodies are affected by the works under this contract. It shall be the duty of the contractor to ensure whether adequate sanction has been obtained from the authority concerned for the work with the help of Kerala Rural Water Supply and Sanitation Agency before the works of such affected portions are undertaken. Any damage caused to any of the manmade structure or any of the utility services will have to be made good by the contractor at his cost. The contractor has to restore the original position if he has to demolish any structure like culverts, compound walls etc during the course of work at his own cost.
2. However, restoration of PWD roads is exception to this. The KRWSA will bear the cost of such restoration of roads provided damaging of the road was essential for the execution of works under this contract. However the contractor should make the road trafficable as far as possible to the maximum extent after the work of laying pipes as per the direction of Engineer in charge.

## **10.2 EARTHWORK EXCAVATION**

Earthwork excavation means earthwork in all classes of soils / rocks whenever removal shall be not by blasting. Earthwork excavation shall be done with adequate care so that underground service lines or adjacent structures are not damaged and appropriate protective measures such as shoring / strutting / sheet piling etc. are adopted for such items as required and approved by the Engineer in charge of the work. The width of trench should be as per the requirement and as per standard data book and a minimum cover above crown of pipe should be maintained as per clause 10.13. If the width of trench exceeds the minimum requirement as noted above, due to faulty workmanship /protection/shoring etc. the additional payment for the extra damaged road width payable to PWD/NH local bodies etc. shall be recovered from the contractor's bill. Excavation by blasting shall be got done only through persons holding valid license for use of explosive material and for blasting purpose. Further all rules prescribed by the Inspectorate of Explosives shall be strictly adhered to whenever blasting is resorted to. Blasted material like the excavated rock shall be the property of Government of Kerala. Disposal of the materials up to a distance of 10 km from the site as well as cartage of excavated material during excavation and back filling up to a maximum distance of 5.0 km will have to be done whenever essential by the contractor at no extra cost.

## **10.3 FILLING / BACK FILLING**

Filling / back filling shall be done only with approved materials. It shall be compacted to get the following results. The density of the filled materials at different depths shall not be less than 95% of the natural field density in case of back fill and shall not be less than 95% of maximum dry density obtained in proctor compaction test or such other approved tests whenever filling is done to get the desired formation ground level. It shall be ensured that the density thus obtained under compaction is uniform at all depths of the fill. The contractor is bound to bear the cost of any test conducted to ascertain the above condition in case of doubt. The filling/backfilling done along PWD roads or such properties owned by other department/institutions, the same shall be further governed by specifications of such owner.

## **10.4 SHORING**

Shoring shall be essential in excavation in all classes of soils whenever depth of excavation exceeds 1.50m and labourers have to work in trenches or close to edges of trenches as per the direction of Engineer in Charge. In ordinary soils and loose soils, shoring shall be done for trenches of shallower depths also considering the chances of collapse of sides. Shoring shall be done as approved/directed by the Engineer in charge of work.

## **10.5 FENCING**

Fencing shall be done in the approved manner along the side of pipeline trenches on roads or other places for preventing accidents on both sides, if required in the opinion of the Engineer in charge.

## **10.6 FORMATION OF ROADS**

Formation of roads shall be done as per IRC rules and regulations for the use of desired class of vehicles mentioned in the scope of the work. Whenever road formation comes in the scope of the work, it shall be understood that all cross drainage work, side drain works, radius of curvature and super -elevation etc. are included in the scope.

## **10.7 RUBBLE MASONRY**

Rubble masonry works using approved quality blasted rubble either as random rubble masonry or coursed rubble masonry shall be permitted. Minimum width of the random rubble masonry shall not be less than 450mm in any case. Only cement mortar 1:6 or richer shall be used for such works. Mixing by weight at the above ratio for mortar shall be permitted only when the fine aggregate is in dry condition. Exposed surfaces of rubble masonry shall be pointed using 1:3 cement mortar to have a pleasing appearance provided it is left unplastered with cement mortar.

## **10.8 BRICK WORK**

Brick masonry using wire cut bricks / first class country burned bricks having a minimum crushing strength of 35 Kg / cm satisfying other tests specified by BIS and least dimensions not less than 70mm shall be permitted. Brick masonry works shall be of minimum 200 mm width, constructed in English bond with cement mortar 1: 6 or richer and plastered with cement mortar 1: 4 or richer in all cases. However, in each case of parapets or other dwarf walls of height less than 700 mm, thickness of masonry can be reduced from 200mm provided pilasters of minimum 200 x 200 mm are constructed monolithic with such walls at a center to center spacing of maximum 3000mm.

## **10.9 PLAIN AND REINFORCED CONCRETE**

### **10.9.1 DESIGN ASSUMPTIONS**

IS 3370 Code of Practice for concrete structure for storage of liquids

**Part I :** 1965 (or latest edition) General requirements

**Part II :** 1965(or latest edition) Reinforced concrete structures.

**Part IV :** 1967(or latest edition) Design tables

IS 2502/1963 (or latest edition) Code of practice for bending and fixing of bars for concrete reinforcement. All RC C/Steel structures shall be based on the relevant IS Codes. Strict adherence must be established to accepted codes of Practice relating to design. Minimum cover to reinforcement of RCC work shall be provided as per IS 456 -2000 (or latest edition). The effect of seismic forces shall be taken into account in the design as per the relevant code of practice.

### **10.9.2 CEMENT**

The contractor will have to procure the cement for the work. The cement used in the work of plant or water front structures should be sulphate resistant - Portland cement of reputed companies having ISI mark. The KRWSA will have the option of rejecting the cement procured by the contractor and ask for replacements, in case of any doubt on quality and age of cement supplied at site. Random /grab sampling and test of the cement will be got done as per the norms of KRWSA.

### **10.9.3 REINFORCING STEEL**

Only Corrosion Resistant Steel (CRS) is to be used for the steel structures. The contractor has to procure all the steel required for the work. The steel so procured should be from reputed companies like SAIL, TISCO etc. and the KRWSA will have the option to select the brand and to ask for replacement, if the material is found not having adequate

quality. The MS/T OR rods supplied for the work shall be cleaned and scrapped to be free of scales rust etc., before placing in forms for R.C.C work.

#### **10.9.4 AGG REGATES**

The coarse and fine aggregates shall comply with IS 388 -1980 or latest edition and may be used after sufficient tests have been carried out and approved by the Regional Project Director. All aggregates shall be stored on hard impervious surface to ensure exclusion of all foreign materials.

#### **10.9.5 WATER**

The water for mix shall be clean and free from harmful matter as per IS standards and taken from a source approved by the Regional Project Director.

#### **10.9.6 ADMIXTURES**

Only where a beneficial effect is produced shall any admixture to be used and that too after tests have been carried out to convince the Regional Project Director that no harmful effect will be produced by the use of such admixture and after approved by the Regional Project Director. Time tested admixtures shall be permitted to be used for concrete based on testimonial of performance to improve the quality of concrete with respect to its strength, water tightness or for other specified purposes as required for the work.

#### **10.9.7 MIXING**

The grade of concrete shall be as per IS 456:2000 or its latest revision. All water retaining or water front structures and machine foundations shall be made in RCC mixes not leaner than M25. The mixing time shall be between 2 to 4 minutes. The contractor should produce mix design for all grades of concrete to be used for the work and get approval from the Regional Project Director before commencement of concreting.

#### **10.9.8 CONCRETING**

The concrete mix shall be in specified proportions satisfying the maximum aggregate size/water cement ratio and required cube strength and workability. Such concrete must be adequately vibrated to form solid mass without voids. External vibration by the use of pneumatic hammers shall be deemed adequate except for thin sections.

#### **10.9.9 TRANSPORTATION AND PLACING**

Transportation and deposition of concrete mix shall be done rapidly and accurately with minimum re-handling. The mix must not be dropped from such a height as may cause segregation and air entrapment. When the mix is placed in position, no further water shall be added to provide easier workability. No concrete mix shall be used for the work if it has been left for a period exceeding its initial setting time before deposited and vibrated into its final position in the member. Sufficient number of cubes must be made for testing as per the relevant BIS code specifications. It shall be tested as per the specification and a complete register of entries shall be maintained by the contractor. It shall be brought to the notice of the Engineer in charge as and when directed by the departmental officer. The cost of all such testing shall be borne by the contractor.



### **10.9.10 CONSTRUCTION JOINTS**

Construction joints shall be avoided wherever possible, and if found necessary, should be of such form to encounter direct compression. A stepped joint being preferred in such a case.

### **10.9.11 CURING**

Curing shall be done as per relevant provisions in the IS code to allow the concrete attain strength through normal hydration and to avoid excessive shrinkage or harmful effect to the member. The method adopted shall be effective and any special method used must be approved by the Regional project Director.

### **10.9.12 REMOVAL OF FORM WORK**

Removal of form work shall be done as per the provisions in the BIS and as per direction of the Regional project Director and in such a manner that no damage is caused to the deflection to minimum deflection, when unsupported and as per the direction of the Regional project Director.

## **10.10 DOORS, WINDOWS AND VENTILATORS**

**10.10.1** Wooden doors and windows and ventilators shall be made as per the approved DATA only and the size of doors, frames, shutters etc shall be not less than the sizes specified in MDSS, PWD standard data book etc. All parts of the door shutter or frame shall contain only hard wood seasoned. Wooden doors and shutters shall be provided for interior doors of office room s/private rooms etc.

**10.10.2** Steel doors, windows and ventilators shall strictly conform to the specifications of BIS. Steel doors, windows and ventilators shall be permitted only for locations where aggressive conditions damaging the doors do not exist and when appearance of the same do not adversely affect the pleasing appearance of the main view and aesthetic condition of the structure. Steel windows and ventilators shall have crossbars for preventing through passage of solid materials of least dimension of 120mm in open position provided in aesthetically pleasing manner.

**10.10.3** For areas directly facing the main views of the structure, aluminium doors, windows and ventilators shall be provided for improving the front view of the structure so far as there are no aggressive surroundings damaging the life or the pleasing appearance. All aluminium Sections shall be anodized as per ISS.

**10.10.4** PVC doors of specifications conforming to those of BIS or of better quality may be used for water closets, bathrooms or other locations where splashing of water may affect the life of other type of doors.

## **10.11 PLASTERING OF EXPOSED SURFACES**

All exposed concrete surfaces shall be plastered with cement mortar 1:4 or richer mixes. Exposed surface means exposed to air or water or any other gaseous or liquid medium. Surfaces of concrete structures other than water retaining structures can be permitted to be left unflustered under the following conditions:

- a) The surface left unflustered is perfectly even without markings of form work or undulations or unevenness greater than 0.5mm.
- b) The surface texture is perfectly uniform and the appearance is pleasing.

## **10.12 TESTING OF WATER RETAINING STRUCTURES**

All water retaining structures shall be filled with water and tested for water tightness before the commencement of plastering. For water retaining structures the requirement of the test shall be deemed to be satisfied if the external faces show no sign of leakage and remain apparently dry, over a period of observation of seven days after filling up to maximum water level and allowing seven days period for absorption, if the structure does not satisfy the condition of the test and the daily drop of water level is decreasing, the period of test may be extended for a further period of seven days, and, if the specified condition of the tests are satisfied, the structure shall be considered to have withstood the test.

## **10.13 PIPES AND PIPE LAYING**

The material and class of pipes used for the contract shall be as specified in the Scope of Works or tender drawings in the "Scope of Works." In case the pipes have not been specified for an item of work, the contractor shall put forth his proposal in accordance with CPHEEO guidelines and rules of BIS and get prior approval from the Engineer in charge. Pipe laid underground shall have a minimum earth cover of 1.00 m above its crown and in such a manner that the bedding angle is not less than 120, and the loads of pipe carrying liquid and the overlaying substance transmitted to the soil uniformly through the entire barrel of the pipe. For AC pipes, such cover above the crown shall be 1.20m at the alignment over which heavy traffic is expected. Whenever special fill materials are required to achieve this goal, sandy soil / river sand shall be provided at no extra cost by the contractor and on the approval obtained from the Engineer in charge. Wherever the cover for the pipe is less than 1.00 m, approved protective measures shall be taken and necessary works executed to see that the pipes are not damaged due to any external loads. In cases where the pipes are laid at ground level, adequate protective works ensuring the safety, serviceability and durability of pipes as approved by the Engineer in charge shall be undertaken as part of the contract. When pipes are over the ground; the support shall be designed and spaced in such a manner that the total stress induced in the pipe shell material at any section does not exceed the safe permissible values. In no case, the socket or spigot shall be allowed to transmit weight of other parts. For design purposes, minimum vertical and horizontal loads of 150 kg/m shall be assumed to act on the pipeline over and above the other known loads. Pipes rising vertically or at angles greater than 20° to the horizontal and which cannot carry / transmit the load through the shell of the barrel uniformly shall be only of flanged pipes. These pipes shall be supported appropriately both vertically and horizontally to ensure the positional fixity in the desired axis in such a manner that no part of shell of the barrel is subjected to stresses above safe permissible values.

During lying of pipe line, the open end of pipes shall be kept closed with dummies, blank flanges or end plugs at closure/suspension of work to prevent entry of soil, or, other unwanted material inside the pipe. No pipe shall be left open for period exceeding 30 minutes even in the presence of responsible personnel. Lying of pipes should be done in accordance with relevant IS codes with its latest amendment and revisions.

### **GENERAL**

This specification covers supply, testing and delivery of DI, GI & PVC pipes of required length. The pipes are to be designed to withstand the effect of internal water pressure, external loads and surge pressure.

The intending tenderers should produce an undertaking with the manufacturers of pipes and specials regarding the capability to cope up with the contract, specification /quality etc. and submit it along with the tender.

### **Quality of materials and manufacture**

Quality of materials and manufacture of pipes and specials should confirm to the relevant BIS or ISO Specification and shall have the respective certification marks of the Standard organization

### **Marking on Pipes**

Each pipe shall be legibly marked with the following details :

- i. Manufacturer's name or trade mark
- ii. Nominal size (as per relevant ISS) Pipe description - class and grade.
- iii. Relevant ISI/ISO Certification markings

All dimensions and specifications shall strictly adhere to the relevant I.S codes/ISO Standards and as amended up to date.

### **Testing of pipes**

The field test pressure to be applied shall not be less than the greatest of the following.

1. 1.5 times the maximum sustained operating pressure
2. 1.5 times the maximum pipeline static pressure
3. Sum of maximum sustained operating pressure and maximum surge pressure
4. Sum of the maximum static pressure and surge pressure subject to a maximum for any pipe and fittings incorporated.

### **SURGE PRESSURE:**

The maximum surge pressure should be analyzed based on the data supplemented and in no case the sum of maximum operating pressure and the calculated surge pressure should exceed the allowable field hydrostatic test pressure. Computer model analysis shall be got done for the pumping line right from the pump's delivery point up to the exit point of water by any reputed institutions approved by the Authority and detailed reports of the institutions shall be furnished to the Authority.

### **HYDRAULIC DESIGN OF PIPE LINES**

Hydraulic design of pipelines etc. where design based on Hazen William's formula as recommended by the Water Supply Manual is used, selection of the formula shall be done to get the higher design values.

### **Design of fittings**

The following information shall be clearly marked on each fitting.

- (1) Nominal size and weight / wall thickness
- (2) Classification based on pressure
- (3) Manufacture's name.

## **10.14 SUPPLY OF MATERIALS**

### **10.14.1 SUPPLY OF PIPES**

All pipes as per the scope of the work supplied should be factory tested and test certificate as per relevant specification/latest code of practice should be produced along with the pipe supplied. The testing of pipes and the authentication of test certificate should be done by an approved third party inspection agency agreeable to KRWSA and witnessed by the technically qualified officers of KRWSA, if the contract value exceeds Rs.100 lakhs and by a Departmental Officer deputed by KRWSA if the contract value is less than Rs. 100 lakhs. In case the pipes are imported from abroad, samples for metallurgical and mechanical tests shall be taken from pipes selected at random and the final acceptance of the pipes will be based on the results of such tests conducted at any of the reputed laboratories.

### **10.14.2 SUPPLY OF M.S PIPES: LINING**

MS pipes are to be lined at the contractors own arranged site located in or around the project area in the presence of Authority Officers. Shop lined pipes will not be accepted. Lining should conform to IS 1916 - 1989 or its latest edition. Minimum lining thickness, cement content, Characteristic compressive strength etc. should be as per the IS specifications. River sand used should be properly cleaned and sieved and only aggregates conforming to IS 383 (or latest edition) and with required uniformity coefficient shall be used.

#### **(a) INSIDE LINING**

Clean the surface of the pipe for removing rust and other unwanted matter by sand blasting or other approved methods. Mound the pipe on the spinning machine and get the cement mortar of 1:2 applied and compacted uniformly by centrifugal action over the entire area. The line pipes shall have a smooth surface inside it and shall be free from ricks and patches after curing. At joints the pipes should be given lining of minimum thickness as per IS specification with CC 1:1 using wire mesh of approved gauge.

#### **(b) OUT SIDE LINING WITH CEMENT MORTAR:**

The surface shall be cleaned as in (a) above. A wire mesh of 50 x 50 x 3 mm or nearest size approved by the Engineer in charge shall be wound over the pipe keeping a uniform gap of 13mm from surface of pipe and fix the same by use of spacers, welding etc. in the approved manner. Cement mortar 1:3 shall be applied by guniting or other approved techniques to attain minimum thickness as per IS specifications and cured appropriately. The surface so finished shall have a fairly uniform finish and shall be free from cracks and patches.

#### **(c) OUTSIDE LINING WITH COALTAR etc.**

Outside lining with hot applied coal tar / as phaltic enamel reinforced with fiber-glass fabric yarn as per IS 10221 -1982 or its latest edition or relevant American / British standards shall be provided based upon the observed soil receptivity in Ohms -cm.

#### **(d) ALL TENDERERS SHOULD QUOTE FOR INSIDE LINING WITH CEMENT MORTAR**

Tenderers who have quoted only for lining with cement mortar inside and outside lining with hot applied coal tar (alternate offer) will not be considered.

(e) After inside lining, pipes should be cured in a curing pond for a minimum period of 7 days or as provided in the latest IS 5822. Minimum cover of pipe as per IS / Manual shall be provided. The detailed specification of site welding of joints should be furnished by the contractor with relevant IS / British / American standards. The welding electrodes used should also conform to relevant IS / British / American Standards.

#### **10.14.3 SUPPLY OF SPECIALS**

The supplied specials should be tested as per relevant specification and latest code of practice. The certificate of testing should be authenticated by the technically qualified officers of KRWSA or a third party agreeable to KRWSA.

#### **8.14.4. SUPPLY OF EQUIPMENTS**

The works to be executed under this contract shall call for procurement of a number of mechanical items and equipments. The contract or shall procure any equipment / item only after the Authority has approved the manufacturer of the same. Any item / equipment procured and used shall, as far as possible bear certification marks of BIS, BSS or such other standard institutions of international repute and shall be brand -new only. Further care shall be taken that any part / component of such equipment, which require periodic replacement, shall be readily available in the market. Equipments requiring periodic replacement of nonstandard, unpopular or odd items shall not be procured or used for the fulfillment of this contract. Equipments requiring periodic maintenance shall be identified and a preventive maintenance schedule prepared for such equipments and handed over to the Authority.

#### **10.14. 5 ELECTRICAL INSTALLATIONS:**

All electrical installations shall be done as per the IE rules and with the concurrence of the Electrical Inspectorate and /or Kerala State Electricity Board. All electrical works shall be done only through approved / licensed persons having qualification, experience and expertise to do the work. It shall be the contractor's sole responsibility to get any clearance from the Electrical Inspectorate.

#### **10.14.6 ELECTRICAL AND ELECTRO - MECHANICAL ITEMS**

All electrical and electromechanical items shall be procured from the manufactures approved by the Authority. Any item procured shall bear certification marks of BIS / BSS or another institution of international repute. For any equipment / system requiring periodic maintenance, preventive maintenance schedule shall be prepared and handed over to the Authority as part of fulfillment of this contract.

#### **10.14.7 VALVES**

- a. Valves shall be as per IS Specification. Valves shall be double -flanged valves unless specifically permitted by the Engineer in charge. It is permitted to use valves of small diameter than the pipe diameter where it is used provided the valve diameter is not less than 67% of the pipe diameter and approved tapers are provided on both sides to ensure that the changes in the cross sectional area is attained gradually. Valves shall have hand wheel except where provisions of hand wheel shall hinder some other specifications requirements. Valves of diameter 400 mm and above shall be geared / butterfly valves. Valves shall be provided with an appropriate seating so that weight is not

transmitted to the adjacent pipe body. Anchoring of pipes at bends or such other locations shall be done in such a manner that the joints of the bend with the straight pipes are not embedded in concrete and easy working of the joints is possible. Scour valves shall be as per the standard specification.

- b. Zero velocity valves / pressure relief valves / surge arrestors etc. shall be used wherever necessary for ensuring the safety of the pipelines. The tenderer should do the water hammer analysis of pumping main and provide appropriate water hammer devices. The system and location proposed should be specifically mentioned in technical bid. The provision of such installations shall be subject to the condition that (i) the hydraulic design of these item are approved by KRWSA (ii) the particular brand valve proposed to be used is a time tested one as per the testimonials furnished, (iii) the guarantee card of the system issued by the manufacturer is handed over to the Engineer in charge (iv) such guarantee issued by the manufacturer / tenderer is valid for a period of not less than 5 years of service and (v) the terms and conditions of the guarantee are accepted to KRWSA / Engineer in charge. Fabricated pipes and specials shall be permitted to be used, provided (i) they shall have definite advantages at the particular place proposed, (ii) they satisfy all design requirements for the efficient and long lasting performance of both hydraulic and other functions and (iii) fabrication shall be attained by the seamless continuous welding.

#### **10.14.8 AIR VALVES**

Suitable air valves shall be as per standard specifications conforming to relevant G& K catalogue. Air valves shall be invariably provided at essential locations inside a valve chamber and all Air valve shall be supported with same size of control valve below it. For more details in scope of work may be referred.

#### **10.14.9 BENDS & SPECIALS**

Bends may be in horizontal plane, vertical plane or in both planes and at angles varying from  $11 \frac{1}{4}^{\circ}$  to  $90^{\circ}$ . Care must be taken to avoid  $90^{\circ}$  bends as far as possible and in case it becomes inevitable, permission for the same must be obtained from the Engineer in charge, before laying of pipeline at that section. Bends and specials shall be procured from manufacturers whose products are time tested and have the approval of BIS. The name of manufacturer/or registered trademark and hydraulic proof test shall be marked on all such specials/fittings. As a special case, non-standard MS fabricated bends/specials will be permitted according to site conditions for non -standard bends with the approval of the Engineer in-charge of the work.

#### **10.14.10 CAST IRON MANHOLE COVERS AND FRAMES**

The basic requirements of the manhole covers to be used shall be of Heavy Duty grade and Square shape for water supply and circular for drainage work. The manhole covers shall be that manufactured from appropriate grade of cast iron, which shall not be inferior to FE 150 conforming to IS 210 (1978) or latest edition. The manufacture and workmanship shall conform to clause 5 of IS 1726 -1991, IS 210 -1978 & IS 4905 -1968 or their latest versions. Suitable locking devices including that with a Galvanized chain and lock or any such foolproof devices as approved by the Engineer before the supply and erection, the manhole cover/frame shall be provided. The minimum dimension of the manhole cover shall not be

less than 60 cm and shall be coated with approved quality of materials as per IS 1726-1991. Each manhole cover and frame shall have embossed on them an identification mark i.e., the mark "KRWSA" to denote Kerala Rural Water Supply and Sanitation Agency together with the manufacture's name /trade mark.

#### **10.14.11 MECHANICAL EQUIPMENT**

The mechanical equipment to be installed in intake structures are as noted below:

##### **(i) Sluice Gates**

Sluice gates on the water front side of the intake structure at minimum 3 levels so as to draw the raw water from the surface of river during flood, normal and drought seasons. The sluice gates must have facility to operate from the deck slab of the pump house and necessary gear and wheel arrangements must be provided. The opening in the intake structure (the sluice gate) must be provided with cast iron gratings so that the solid or floating material will not enter inside the intake. Such grating or screens shall be easily cleanable of the debris adhering to them.

##### **(ii) Float & Scale Type Water Level Indicator**

Water level indicator of float and scale type fabricated with corrosion resistant material approved by the Engineer in Charge must be provided in the Intake well. The location of the indicator and its design etc. must have the approval of the Engineer before its fabrication / installation. The details must be furnished before the Engineer as a submittal with detailed drawings and specification of construction. The float shall be of Copper, Brass or other corrosion resistant material approved by the Engineer, floats shall have appropriate guide for vertical movement, which shall facilitate easy vertical sliding. The guides shall be corrosion resistant material and fixed in such a manner that the floats in case of any repair, can be removed and kept back in position without disturbing the guides or easy and quick dismantling and refitting is possible.

##### **(iii) Over head gantry crane**

The pump house shall be equipped with gantry cranes of appropriate capacity and as per Volume II (scope of work). The gantry crane with pulley block shall have sufficient freedom of movement so that the entire pump house area can be covered by it. The design and other particulars of the gantry crane must be furnished to the Engineer in charge as a submittal before its procurement and got approved by him.

##### **(iv) Pumps and Motors**

The pumps and motors supplied and installed at intake structures and at any pumping stations of the project shall be of reputed make. The design of pump set shall be in such a way that energy consumption during the starting and operating conditions are minimum. Pumps shall have optimal efficiency for the specified / desired discharge as per tender throughout the design life of pump set. The selection of number of pump sets shall be made in such a way that at least 50% stand by is available at any time if the number of pump sets required at each station is not otherwise specified. In case of more than one pump working in combination, either in parallel or series, the different working conditions shall be separately studied and the best energy – economy condition shall be selected. The analysis on operation conditions, the design and the performance characteristics of the pump sets shall be furnished to the

Engineer in Charge as a submittal and his prior approval of the same is essential before the actual procurement and installation. In case the tenderer is not the manufacturer of a particular item, he shall disclose the manufacturer of each and every item he proposes to procure for the project. In every such case, he shall present a list of not more than two manufacturers from whom he is planning to procure the items in the order of preference. For preventive maintenance of the pumps, motors and switch gears, consumable spares for the next two years after the completion and commissioning of the work shall be provided by the contractor. The contractor shall also furnish the list of vendors from whom such spares can be procured in future.

**(v) Motors, Gears etc.**

Motors, gears or such other equipments having constantly moving parts while in service, if installed out door, shall invariably be kept only in metallic boxes / other protective enclosures to protect the equipment from intense sun light, rain and dust. Such items should be quite durable and free from deterioration due to environmental conditions.

**(vi) Electrical Panel Boards & Switch gears**

It shall be the responsibility of the contractor to supply and install suitably designed electrical panel boards, which shall have necessary provision for taking the power supply from KSEB. All such panel boards shall satisfy and comply with the rules and regulations of the Electrical Inspectorate. The contractor shall carry out all such electrical works through a licensed electrical contractor as per the requirements of I E rules. The design and details of the electrical system at each station together with the specifications of the proposed panel board, circuit breakers, fuse units etc, shall be submitted to the Engineer in charge for his approval, before actual commencement of work and submission to the Electrical Inspectorate. All such items shall be of reputed make and the manufacturer /supplier of each item shall be specified in the submittal along with all other relevant details. The panel boards shall be painted with anticorrosive epoxy paint of approved colour and each installations shall be suitably indicated with name plated on the panel boards. The electrical panels, motors etc. shall be suitably indicated with name plates on the panel boards. The electrical panels, motors etc. shall be suitably indicated with name plates on the panel boards earthed as per IE rules. It shall also be the duty of the contractor to obtain necessary clearance and approval of the electrical inspectorate in all the electrical and electro-mechanical equipments provided for the project as a part of this contract. Instances may occur when it may become necessary for providing transformers for drawing power from KSEB and in all such cases, the supply and erection of transformers, yard structures, switchgears and panel boards shall have to be done as a part of this contract as per IE Rules and Regulations. The contractor shall fully envisage these things and shall have to execute all such works through licensed personnel and obtain the clearance of Electrical Inspectorate for the proper commissioning and functioning of the system.

**(vii) Deleted**

**10.15 VALVE CHAMBERS**

Valve chambers shall be constructed as per the dimensions provided on the Scope of Work. The construction shall be done only as per the drawing approved by the Engineer in charge. The material used for construction shall be best quality wire cut bricks and both sides plastered



/ RR with inside plastering / RCC depending upon the design load conditions, availability of space environmental impacts etc. Underground valve chambers along motor able roads shall be of RCC. The design of the valve chamber including that of the cover slab indicating the location, size and class of the manhole cover etc. must be furnished to the Regional Project Director before the actual construction, and, his approval must be received before the commencement of the work at site.

#### **10.16 ANCHOR BLOCKS**

All the bends in pipelines (from 11 1/4) shall be provided with suitably designed Anchor blocks. The design of Anchor blocks shall be prepared as per the Water Supply Manual and relevant I.S. Codes and got approved by the Engineer in charge before execution.

#### **10.17 DISCHARGE OF EFFLUENT**

Discharging any effluent which may either be a bye product of the system or waste from the system, as a result of trial run or otherwise, shall be done carefully not inviting opposition / resistance / objection from any corner. If such discharge requires any form of treatment or any type of civil or other structures for the preservation of original environment conditions, the tenderer shall include such works also in his of forever though such a work has not been envisaged in this document.

#### **10.18 ARCHITECTURAL FEATURE**

Architectural features of the structures constructed shall be pleasing, attractive and matching to the site conditions. Selection of colour combinations, ornamental works, materials used for such ornamental works etc. shall be done bearing in mind the following properties as (1) fading phenomenon, (2) resistance to severe climatic conditions (3) strength to withstand unexpected forces that may act on the material / member etc.

#### **10.19 NON DESTRUCTIVE TEST FOR STRENGTH:**

Any constructed structure or erected equipment shall be subject to a non destructive test to ensure or certify about its capacity to yield the desired service if required by the Engineer in charge. Such tests shall be the ones specified by the ISS / BSS / CPHE EO Manuals or a more severe test. An equipment / component shall be deemed to have satisfactorily passed such a test only if the Engineer in Charge of the works is satisfied on the performance under test conditions.

10.20 deleted.

#### **10.21 If any of the conditions above are in contradiction to any of the clauses in the scope of Work, the clause/conditions of the Scope of Work shall prevail**

**10.22** Contractors/Firms shall not appoint/employ directly/indirectly the retired employees of Kerala Rural Water Supply and Sanitation Agency within 3 years of their retirement/Voluntary retirement/ contract termination.

**Regional Project Director**



## **KERALA RURAL WATER SUPPLY AND SANITATION AGENCY**

**Name of Work : Providing additional well, tank and  
Maintenance works to Pulvetta WSS in Karuvarakundu GP,  
Malappuram District**

**E-TENDER No : 04/SUS/KRWSA/RPMU/MPM/KAR/2022**

**DUE DATE & TIME FOR  
UPLOADING OF TENDER BY TENDERER : 03/12/2022, 03.00 PM**

**TENDER OPENING DATE : 05/12/2022, 11.00 AM**

## **NOTICE INVITING TENDER**

### **VOLUME – II**

### **SCOPE OF WORKS**

**OFFICE OF THE REGIONAL PROJECT DIRECTOR**

**KERALA RURAL WATER SUPPLY AND SANITATION AGENCY**

**RPMU MALAPPURAM**

**KERALA STATE**

**TELEPHONE: 0483 2738566**

**Email ID : [rpmumalappuram1@gmail.com](mailto:rpmumalappuram1@gmail.com)**

**Price Bid - BoQ**

**Separately attached**

## **CONTENTS**

<b>Sl. No.</b>	<b>Description</b>	<b>Page no.</b>
1	Scope of the work	60
	General	60
	Tentative requirement of various components	60
2	APPENDIX – I to II	62
3	ANNEXURES – I to III	64

# **KERALA RURAL WATER SUPPLY AND SANITATION AGENCY**

## **SCOPE OF WORK**

### **A. GENERAL**

This project is to Enhance the Pulvetta Water Supply Scheme in Karuvarakund Grama Panchayath, Malappuram District under Sustainability Project 2021-22. The scheme already have a well and two OHSR tanks, but it is seems to be inadequate for smooth working of the scheme. The proposed work include construction of additional well, pumphouse and an over head storage reservoir, supply and installation of new pumpset and related works.

### **B. TENTATIVE REQUIREMENT OF VARIOUS COMPONENTS**

<b>WELL (RCC well)</b>	
Diameter	6m
Depth	10m
<b>PUMP HOUSE (above well using AAC blocks)</b>	
Length	2.2m
Breadth	2.2m
Height	2.1m
<b>TANK (RCC OHSR)</b>	
Capacity	25000 L
Height from GL	3m
Tank Dimension	4mx4mx2.2m
<b>PUMP SET (open well submersible, 12.78 lps, 129m head)</b>	

Approximate quantities are listed above and the actual quantities may vary as per site conditions.

**APPENDIX - I**  
**List of IS CODES to be followed**

IS 456-2000	Reinforced Cement Concrete
IS 3370-2009	Part 1&2 Concrete structures for storage of water
IS 1893-2002	Part1 Earthquake resistant design
IS 10500-1991	Drinking water
IS 8329-2000	DI pipes
IS 4985-2000	uPVC pipes
IS 3589-2001	MS pipes
IS 1239 part1-2004	GI pipes
IS 269-2013	Cement OPC
IS 1489-1991	Cement PPC
IS 1536-2001	CI pipes
IS 8329-2000	DI pipes
IS 1848-2000	Air valves
IS 1846-2000	sluice valves
IS 4984 – 2016	PE Pipes
IS 7634(Part2)-2012	Laying & Jointing PE pipes

Above IS codes with latest amendment to be followed

APPENDIX - II  
DRAWINGS

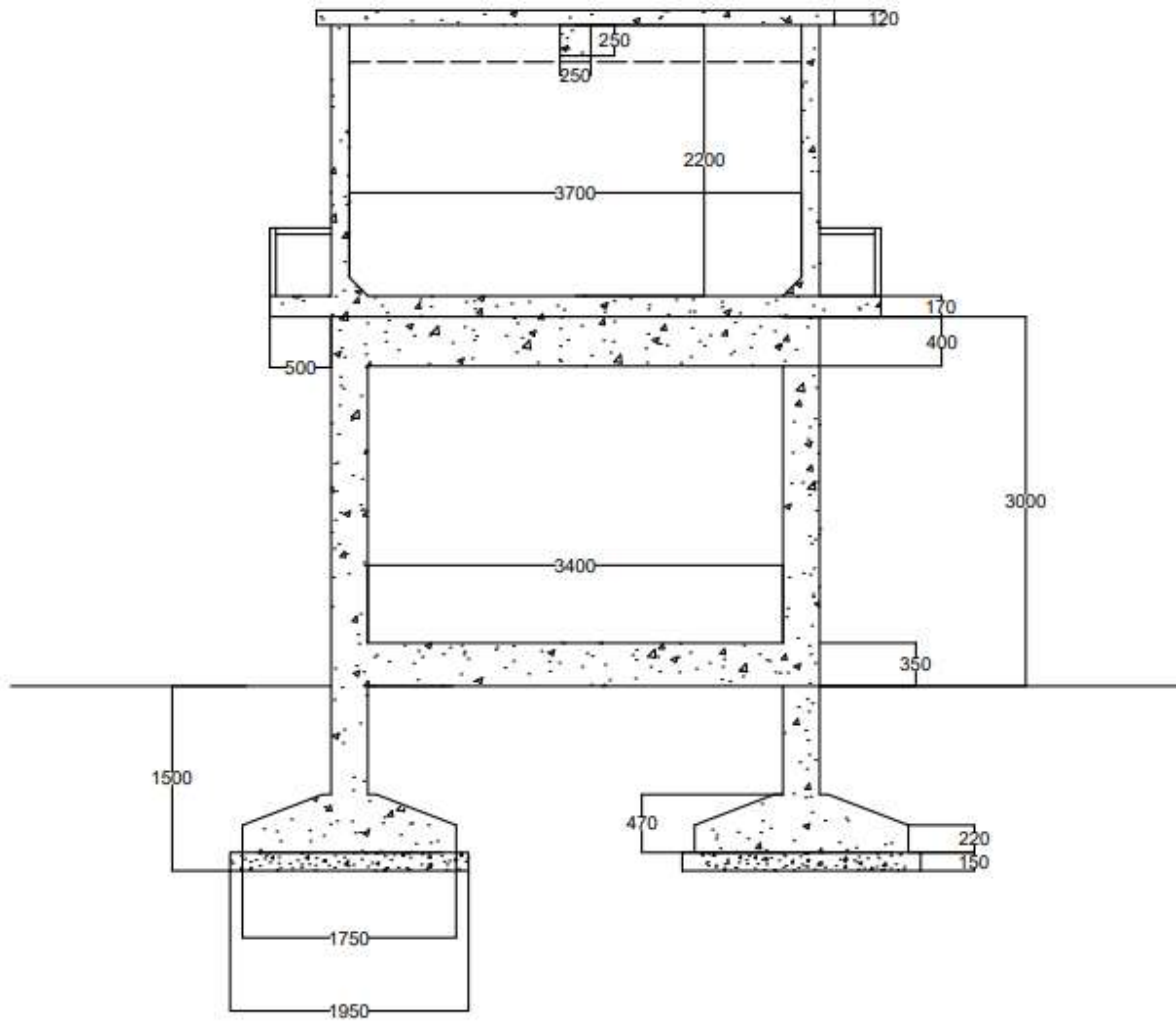

Figure 1. OHSR (All dimensions are in mm)

**ANNEXURE - I**

**FORM OF DECLARATION OF NON RELATIONSHIP**

I .....  
do hereby declare that there are no persons in my relationship like Father, Mother, Son, Wife, Daughter, Brother, Sister, Nephew, Father-In-Law, Mother-In-Law, Brother-In-Law, Sister-In-Law or Cousins of the prior mentioned is related to any officers of the Kerala Rural Water Supply and Sanitation Agency, who is in charge of or having control over the work of Providing additional well, tank and Maintenance works to Pulvetta WSS in Karuvarakundu GP, Malappuram District (E-Tender No. 04/SUS/KRWSA/RPMU/MPM/KAR/2022)

Contractor

**ANNEXURE - II**

**UNDERTAKING REGARDING DELAYED WORKS IN KRWSA/NON  
BLACKLISTED**

I .....  
do hereby certify that I have not delayed two or more works in KRWSA, in the past ten years prior to the date of tender of Providing additional well, tank and Maintenance works to Pulvetta WSS in Karuvarakundu GP, Malappuram District (E-Tender No. 04/SUS/KRWSA/RPMU/MPM/KAR/2022)

I also certify that as a contractor/NGO, I was not black listed by any competent authority till date

Contractor

**Note :** If the contractor is found at any stage to have suppressed any information required, his earnest money for the work is liable to be forfeited and the contract entered into will stand cancelled.

**ANNEXURE - III:**

**MAJOR GOVERNMENT ORDERS/APPROVALS FOR CONSTITUTING  
MISSION / COMMITTEES**





GOVERNMENT OF KERALA

Abstract

Finance Department – Execution of public works on Item Rate Contracts –  
Regulating the abnormally high quoted and low quoted items – Clarifications –  
Orders issued

---

FINANCE (INDUSTRIES & PUBLIC WORKS - B) DEPARTMENT

G.O.(P)No. 54/2019/Fin.

Dated, Thiruvananthapuram, 04.05.2019

---

- Read :-
- 1) G.O.(P) No. 324/2015/Fin dated 30.07.2015
  - 2) G.O.(P) No. 30/2016/Fin dated 29.02.2016
  - 3) G.O.(P) No. 16/2017/Fin dated 06.02.2017
  - 4) G.O.(P) No. 8/2018/Fin dated 15.01.2018
  - 5) G.O.(P) No. 154/2018/ Fin dated 01.10.2018

**ORDER**

As per the Government Order cited 1<sup>st</sup> and 2<sup>nd</sup> papers, all tenders for public works costing more than ₹ 5 lakhs shall be invited through E-tender portal on Item Rate Contract only. Vide Government Order read as 3<sup>rd</sup> and 5<sup>th</sup> papers, Government have dispensed the Tender Committees at Government level and delegated powers to the Departmental Tender Committees at Chief Engineer, Superintending Engineer and Executive Engineer levels for approving the tenders subject to certain conditions.

2) In order to avoid time and cost over run on account of deviations necessitated during the course of execution of work, as per the Government Order read as 4<sup>th</sup> above, instructions were issued to all Government Departments and PSUs to ensure the detailed investigation, design, estimation etc while according Administrative Sanction itself. It was also stipulated that if revision of estimates in excess of 10% of Technical Sanction amount is necessitated due to lapses in

investigation / design / planning / estimation, the Officers will be made accountable and proceeded against.

3) As per relevant Clauses of Government approved Standard Bidding Document (SBD), the contractor is bound to execute excess quantities up to 25% of scheduled quantity at contract rates. The criteria to be adopted for fixing the rates for excess quantities and extra items are also mentioned in the SBD.

4) However, some discrepancies have been observed while processing of tenders and execution of works under Item Rate Contracts. Also instances have been noticed where the low quoted items are excluded during execution and excess quantities of high quoted items are executed without adequate technical justification, resulting in heavy loss to the public exchequer.

5) In order to avoid such instances in future, Government are pleased to issue the following clarifications on Item Rate Contracts to all Government Departments and PSUs:-

- 1) Tenders for all public works costing more than ₹ 5 lakh shall be invited through E-tenders on Item Rate Contract only.
- 2) The bidder who has quoted lowest total amount shall be considered as L1.
- 3) The quoted rates of L1 for all items may be compared with current DSR and current LMR. The items whose quoted rates are more than current DSR may be treated as High Quoted Items and less than current DSR may be treated as Low Quoted Items.
- 4) Negotiations shall be done with L1 only to reduce the high quoted rates so as to explore the possibility for bringing them within DSR + 10% tolerance limit or LMR, which ever is lower.
- 5) The admissible contract amount will be least of (i) Negotiated Contract PAC of L1 (ii) Estimate amount based on current LMR and (iii) Estimate amount based on current DSR plus 10% tolerance limit.
- 6) The quoted rates with deviation of more than (+/-) 25% over Technical Sanction Estimate Rates may be treated as Abnormally High Quoted Rates

- (AHQR) item / Abnormally Low Quoted Rates (ALQR) item, as the case may be. In respect of AHQR item, under normal circumstances, the contract rate is applicable for the scheduled quantities in the Agreement only.
- 7) In case of quantities exceeding the agreement schedule quantities and up to 25% limit that are necessitated for proper completion of work, the contract rates of corresponding item shall apply.
  - 8) For excess quantities, i.e, quantities in excess of 25% over agreement schedule quantities, the admissible rates shall be limited to Technical Sanctioned Estimate Rate modified by overall tender excess / tender deficit, as the case may be, subject to a maximum of PWD local market rates prevailing at the time of ordering.
  - 9) In case of ALQR items, sanction of Technical Sanction authority shall be insisted before limiting execution of concerned item less than 75% scheduled quantity.
  - 10) The relevant clauses of Standard Bidding Document (SBD) and Kerala PWD Manual 2012 shall be modified accordingly.

**By Order of the Governor,  
SANJEEV KAUSHIK IAS  
Principal Secretary (Finance-Resources)**

To

The Principal Accountant General (A&E) Kerala, Thiruvananthapuram  
The Principal Accountant General (G&SSA) Kerala, Thiruvananthapuram  
The Accountant General (E&RSA) Kerala, Thiruvananthapuram  
The Principal Accountant General (Audit) Kerala, Thiruvananthapuram  
All Heads of Departments and Offices  
The Secretary to Governor  
All Departments of Secretariat  
All Private Secretaries to Ministers  
Private Secretary to Chief Minister  
Private Secretary to the Leader of Opposition  
All Secretaries to Government

The Registrar, High Court of Kerala  
The Secretary, Kerala Human Rights Commission, Thiruvananthapuram  
The Election Commissioner, State Election Commission, Thiruvananthapuram  
The Registrar, University of Kerala/Cochin/Kozhikode/Kottayam  
The Nodal Officer, [www.finance.kerala.gov.in](http://www.finance.kerala.gov.in)  
Stock file/Office Copy (E-1153587)

Forwarded/By Order

*Haylonel*

Section Officer



GOVERNMENT OF KERALA

Abstract

Finance Department – Revision of tender fee , Earnest Money Deposit, Performance Guarantee etc – modified orders issued

FINANCE (INDUSTRIES & PUBLIC WORKS - B) DEPARTMENT

G.O.(P) No. 429/15/Fin

Dated, Thiruvananthapuram, 28.09.2015

Read:- 1. G.O(P) No.3/2015/Fin dated 5.1.2015

2. G.O(P) No.295/15/Fin dated 15.7.2015

ORDER

Government issued orders revising/clarifying the rates of tender fee, Earnest Money Deposit, Performance Security Deposit etc vide orders read above. It has now come to the notice of Government that certain points mentioned in the above Government Orders require further clarity to avoid ambiguity while execution of public works. Government are therefore pleased to issue the following modifications on the orders issued in Government Orders read above.

1. Tender fee :-

In order to enhance competition in execution of public works, the cost of tender fee has been rationalized as follows.

Cost of Work	Tender fee
i) Upto Rs. 50,000	i) Rs.300
ii) Above Rs.50,000 - upto Rs.10 Lakh	ii) 0.2% of cost of work (subject to a minimum of Rs.500 and maximum of Rs.2000)
iii) Above Rs.10 Lakh - upto Rs.1 crore	iii) Rs.2500

2500/-

iv) Above Rs.1 crore-upto Rs.2Crore	iv) Rs.5000
v) Above Rs.2 crore – upto Rs.5 crore	iv) Rs.7500
vi) Above Rs.5 crore -upto Rs.10 crore	v) Rs.10,000
vii) Above Rs.10 crore	vi) Rs.15000

## 2. Earnest Money Deposit (EMD)

Earnest Money Deposit (EMD) is collected to ensure serious participation in the bidding process and this amount will be returned soon after finalising the lowest bidder. Taking into consideration of the fact that fixing higher amount will reduce competition the rates of EMD has been revised as follows.

Cost of Work	Amount of EMD
i) upto Rs.2 crore	i) 2.5% of the project cost, subject to a maximum of Rs 50,000
ii) Above Rs 2 Crore up to Rs 5 Crore	ii) Rs.1 lakh
iii) Above Rs.5 Crore upto Rs.10 Crore	iii) Rs.2 lakh
iv) Above Rs.10 Crore	iv) Rs.5 lakh

3. Government have gone through the CPWD system where Performance Guarantee and Security Deposits are collected in different modes and at different time intervals. The definitions adopted in old and revised PWD manual are also creating some confusions in the following terminologies. Government therefore clarify the position as follows.

### i) Performance Guarantee :

Performance Guarantee , the amount collected at the time of executing contract agreement ,will be 5% of the contract value(agreed PAC)and the

deposit will be retained till the expiry of Defect Liability Period. At least fifty percent(50%) of this deposit shall be collected in the form of Treasury Fixed Deposit and the rest in the form of Bank Guarantee or any other forms prescribed in the revised PWD Manual.

**ii) Additional Performance Guarantee**

Additional Performance Guarantee is the additional amount to be deposited for unbalanced price ie , for works quoted below estimate rate. The collection of additional deposits is a disincentive to the bidder who offers to execute a work below estimated rate and this will induce the contractor to quote a rate equal to or higher than estimated rate. Government therefore decided to do away with additional performance guarantee for all works quoted below upto 10% of the estimate rate. Additional performance guarantee will be required if works quoted between 11% to 25% below estimate rate .

**iii)Performance Security Deposit:**

Security Deposit is the retention amount deducted from the running bill of the contractors in addition to the performance guarantee. This will be @2.5% of the gross amount of each running bill so that the amount so retained shall be 2.5% of the value of the work done till then. This can be released against Bank Guarantee on its accumulation to a minimum amount of Rs.5 lakh subject to the condition that the amount of Bank Guarantee except last one shall not be less than Rs.5 lakhs. This amount will be released after passing of final bill as in the case of refund of deposit.

4. These instructions will be applicable to all engineering Departments and supercedes the Government orders read above .

5. The revised rates will be applicable to all tenders floated after the date of issue of this order. However cases already settled will not be reopened.

By Order of the Governor  
DR.K.M.ABRAHAM  
Additional Chief Secretary (Finance)

To

The Accountant General (A&E) Kerala, Thiruvananthapuram  
The Accountant General (G&SSA) Kerala, Thiruvananthapuram  
The Accountant General (E&RSA) Kerala, Thiruvananthapuram  
All Heads of Departments and Offices  
All Departments of Secretariat  
All Private Secretaries to Ministers  
Private Secretary to Chief Minister  
Private Secretary to the Leader of Opposition  
All Secretaries to Government  
The Secretary, Kerala Public Service Commission,  
Thiruvananthapuram (with C/L)  
The Registrar, University of Kerala/Cochin/Kozhikode/Kottayam  
(with C/L)  
The Registrar, High Court of Kerala  
The Secretary, Kerala Human Rights Commission,  
Thiruvananthapuram  
The Managing Director, Kerala State Transport Corporation,  
Thiruvananthapuram (with C/L)  
The Secretary, Kerala State Electricity Board,  
Thiruvananthapuram (with C/L)  
The Secretary to Governor  
The Nodal Officer, [www.finance.kerala.gov.in](http://www.finance.kerala.gov.in)  
Stock file/Office Copy

Forwarded/By Order

  
Section Officer



Very Urgent  
By Spl. Messenger



GOVERNMENT OF KERALA

Abstract

Finance Department- Additional Performance Guarantee- further clarification- Orders issued

-----  
**FINANCE (INDUSTRIES & PUBLIC WORKS - B) DEPARTMENT**  
G.O.(P)No.19/2016/Fin Dated, Thiruvananthapuram, 03/02/2016

-----  
Read:- G.O.(P) No. 429/15/Fin dated 28.9.2015

ORDER

Government vide order read above ordered among other things that no additional performance guarantee shall be collected for works quoted below upto 10% of the estimate rate to enhance competition . However additional performance guarantee will be insisted if the amount quoted is between 11% to 25% below estimate rate and no tender shall be accepted below this limit to ensure reasonable quality of works.

2. Now doubts have arisen as to whether additional performance guarantee need be collected in case of works having quoted rates between 10% and 11% below estimate rates. The clarifications were also sought as to whether exemption allowed upto 10% below estimate rate need be applied to rates quoted between 10% and 25%. Accordingly the position is clarified as follows.

“ Additional performance guarantee will be required in all cases where quoted rate falls below 10% of the estimate cost but the maximum permissible lower limit is 25% below the estimated cost.

The 10% standard exemption will be applicable to all estimates quoted below estimate cost upto 25 %. If the rate quoted by the contractor is "x%" below estimate cost (where x lies above 10% and upto 25%) the performance guarantee for an amount equal to (x-10)% of the estimate amount shall be obtained from the contractor"

3. Government order read above stands modified to the above extend.

4. This clarification will take effect from the date of order and cases settled otherwise will not be reopened.

(By Order of the Governor)

AJAYAKUMAR. A.R.

Additional Secretary (Finance).

To

The Accountant General (A&E) Kerala, Thiruvananthapuram  
 The Accountant General (G&SSA) Kerala, Thiruvananthapuram  
 The Accountant General (E&RSA) Kerala, Thiruvananthapuram  
 All Heads of Departments/Offices  
 Private Secretary to Chief Minister  
 All Private Secretaries to Ministers  
 Private Secretary to the Leader of Opposition  
 All Secretaries to Government  
 The Secretary, Kerala Public Service Commission,  
 Thiruvananthapuram  
 The Registrar, University of Kerala/Cochin/Kozhikode/Kottayam  
 The Registrar, High Court of Kerala  
 The Secretary, Kerala Human Rights Commission,  
 Thiruvananthapuram  
 The Managing Director, Kerala State Transport Corporation,  
 Thiruvananthapuram  
 The Secretary, Kerala State Electricity Board,  
 Thiruvananthapuram  
 The Secretary to Governor  
 All Secreteraiat Departments.  
 The Nodal Officer, [www.finance.kerala.gov.in](http://www.finance.kerala.gov.in)  
 Stock file/Office Copy

Forwarded/By Order

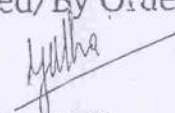
  
 Section Officer



GOVERNMENT OF KERALA

Abstract

Finance Department-Award of work when contractor quotes rates less than 75% of the Estimated value of work-clarification-Orders issued.

Section: -----

**FINANCE (INDUSTRIES & PUBLIC WORKS - B) DEPARTMENT**

G.O.(P)No.124/2016/Fin Dated, Thiruvananthapuram, 29/08/2016

Read:- 1. G.O.(P) No. 13/2012/PWD dated 1.02.2012

ORDER

The clause 2009.4 of PWD Manual 2012 envisages that the tender/quotation with quoted PAC less than 75% of the estimated PAC shall not be accepted, since awarding of such works may lead to failure of contract or poor quality of work executed by the contractor and wastage of public money.

2. At present, estimates are prepared using PRICE Software in DSR 2014. It has been observed that many bids are now received at 25% below or even less than the estimated PAC owing to reduction in cost of bitumen, steel or due to any site specific advantage etc. and transparent competition due to e-tendering. Government therefore consider that the existing clause in PWD Manual need a revisit.

3.The Government after having examined this case in detail, are pleased to issue the following guidelines for processing quotes below 25% of estimated PAC, in partial modifications of Clause 2009.4 of Revised PWD Manual.

- i. The tender with lowest quoted rate less than 75% estimated PAC shall not be rejected if sufficient

- competition is ensured and the rate quoted by the second and third lowest bidder are also comparatively nearer to the lowest bidder.
- ii. The tender inviting authority shall obtain a statement from the lowest bidder quoting rates below PAC regarding the reasonableness of the rate quoted to assess that whether the quoted rates are workable.
  - iii. Assessment shall be made by Department also, as to whether the particular work has any rate advantage as compared to the rate as given in Price Software Viz. reduction in cost bitumen, steel etc.
  - iv. If any contractor quotes less than 75% of the estimated PAC and variation with all other quoted rates are much higher, the Tender accepting Authority shall take appropriate decision based on merits.
  - v. The above guidelines will come into force with immediate effect.

(By Order of the Governor)  
Dr. K.M.ABRAHAM  
Additional Chief Secretary (Finance).

To

The Accountant General (A&E) Kerala, Thiruvananthapuram  
The Accountant General (G&SSA) Kerala, Thiruvananthapuram  
The Accountant General (E&RSA) Kerala, Thiruvananthapuram  
All Heads of Departments/Offices  
Private Secretary to Chief Minister  
All Private Secretaries to Ministers  
Private Secretary to the Leader of Opposition  
All Secretaries to Government  
The Secretary, Kerala Public Service Commission,  
Thiruvananthapuram  
The Registrar, University of Kerala/Cochin/Kozhikode/Kottayam  
The Registrar, High Court of Kerala  
The Secretary, Kerala Human Rights Commission,  
Thiruvananthapuram



GOVERNMENT OF KERALA

Abstract

Finance Department – Acceptance of Guarantee issued from Kerala Financial Corporation for the execution of public works – Orders issued

---

FINANCE (INDUSTRIES & PUBLIC WORKS - B) DEPARTMENT

G.O.(P)No.168/2018/Fin.

Dated, Thiruvananthapuram, 02.11.2018

---

- Read :-
- 1) G.O.(P) No. 429/2015/Fin dated 28.09.2015
  - 2) U.O.(f) No. PWD-H3/154/2018-PWD
  - 3) Letter No. KFC/Credit/687/2018 dated 11.07.2018 from the Chairman and Managing Director, Kerala Financial Corporation.
  - 4) Letter No. FR2-125/2018 dated 19.09.2018 from the Chief Engineer, PWD (Roads & Bridges).

ORDER

Government issued orders revising / clarifying the rate of tender fee, Earnest Money Deposit, Performance Security Deposit vide Order read 1<sup>st</sup> above. Now, vide letter read 3<sup>rd</sup> paper above, the Chairman and Managing Director, Kerala Financial Corporation has requested to include Kerala Financial Corporation in the list of institutions from which performance guarantee for the works can be accepted. The Chief Engineer, PWD (Roads & Bridges) vide letter read as 4<sup>th</sup> paper above has reported that Public Works Department has no objection in permitting Kerala Financial Corporation to offer performance guarantee for public works, provided they are authorized to do so.

Government have examined the matter in detail and are pleased to modify Para 3(i) of the Government Order read as 1<sup>st</sup> paper as follows:-

“Performance Guarantee, the amount collected at the time of executing contract agreement will be 5% of the contract value (agreed PAC) and the deposit will be retained till the expiry of Defect Liability Period. At least Fifty percent (50%) of this deposit shall be collected in the form of Treasury Fixed Deposit and rest in the form of Guarantee issued from Nationalized / Scheduled Bank / Kerala Financial Corporation or any other forms prescribed in the revised PWD Manual”.

Para 3(i) of the Government Order read above modified to the above extent.

**By Order of the Governor,  
SANJEEV KAUSHIK  
Principal Secretary (Finance-Resources)**

To

The Principal Accountant General (A&E) Kerala, Thiruvananthapuram  
The Principal Accountant General (G&SSA) Kerala, Thiruvananthapuram  
The Accountant General (E&RSA) Kerala, Thiruvananthapuram  
All Heads of Departments and Offices  
The Secretary to Governor  
All Departments of Secretariat  
All Private Secretaries to Ministers  
Private Secretary to Chief Minister  
Private Secretary to the Leader of Opposition  
All Secretaries to Government  
The Registrar, High Court of Kerala  
The Secretary, Kerala Human Rights Commission, Thiruvananthapuram  
The Election Commissioner, State Election Commission, Thiruvananthapuram  
The Registrar, University of Kerala/Cochin/Kozhikode/Kottayam  
The Nodal Officer, [www.finance.kerala.gov.in](http://www.finance.kerala.gov.in)  
Stock file/Office Copy (E-1000428)

Forwarded/By Order

  
Section Officer



GOVERNMENT OF KERALA

Abstract

Finance Department – Additional Performance Guarantee – Mode of remittance – Orders issued

FINANCE (INDUSTRIES & PUBLIC WORKS - B) DEPARTMENT

G.O.(P)No.1/2019/Fin.

Dated, Thiruvananthapuram, 10.01.2019

- Read :-
- 1) G.O.(P) No. 429/2015/Fin dated 28.09.2015
  - 2) G.O.(P) No. 19/2016/Fin dated 03.02.2016
  - 3) G.O.(P) No. 124/2016/Fin dated 29.08.2016
  - 4) G.O.(P) No. 168/2018/Fin dated 02.11.2018
  - 5) Letter No. KWA/JB/WS2/11878/AMRUT/18/TD dated 23.11.2018 from the Managing Director, Kerala Water Authority.

ORDER

As per the Government Order read as 2<sup>nd</sup> above, if the quoted amount of lowest bidder (L1) is X% below estimated PAC (where X lies above 10% and up to 25%), the Additional Performance Guarantee amount shall be (X - 10)% of estimated PAC. Also, as per the Government Order read as 3<sup>rd</sup> above, Government have lifted the restrictions in Kerala PWD Manual 2012 on awarding of contract for public works at quoted amounts less than 75% of estimated PAC. Later, as per the Government Order read as 4<sup>th</sup> above, it was clarified that 50% Performance Guarantee shall be collected in the form of Treasury Fixed Deposit and rest in the form of Guarantee issued from any Nationalized Bank / Scheduled Bank / Kerala Financial Corporation or any other forms prescribed in the Kerala PWD Manual.

As per the letter read as 5<sup>th</sup> above, the Managing Director, Kerala Water Authority has sought clarifications on mode of payment of Additional Performance Guarantee since the same is not seen mentioned in the above Government Orders.

29/19/19

EE(WS)  
19/1/19  
DCE(W)

AEE 2 ✓

SS  
19/01/19  
EE(WS)

ASR  
19/1

Government have examined the matter in detail and are pleased to issue the following clarifications to all Government Departments and PSUs on Additional Performance Guarantee:-

- i. If the quoted amount of lowest bidder (L1) is X% below estimated PAC, the Additional Performance Guarantee amount shall be (X - 10)% of estimated PAC.
- ii. 50% of Additional Performance Guarantee shall be in the form of Treasury Fixed Deposit and rest in the form of Guarantee issued from any Nationalized Bank / Scheduled Bank / Kerala Financial Corporation or any other forms prescribed in the Kerala PWD Manual.
- iii. Additional Performance Guarantee shall be collected before executing the agreement in the same form as Performance Guarantee and may be released while passing the final contract bill.

By Order of the Governor,  
SANJEEV KAUSHIK  
Principal Secretary (Finance-Resources)

To

The Principal Accountant General (A&E) Kerala, Thiruvananthapuram  
The Principal Accountant General (G&SSA) Kerala, Thiruvananthapuram  
The Accountant General (E&RSA) Kerala, Thiruvananthapuram  
All Heads of Departments and Offices  
The Secretary to Governor  
All Departments of Secretariat  
All Private Secretaries to Ministers  
Private Secretary to Chief Minister  
Private Secretary to the Leader of Opposition  
All Secretaries to Government  
The Registrar, High Court of Kerala  
The Secretary, Kerala Human Rights Commission, Thiruvananthapuram  
The Election Commissioner, State Election Commission, Thiruvananthapuram  
The Registrar, University of Kerala/Cochin/Kozhikode/Kottayam  
The Nodal Officer, [www.finance.kerala.gov.in](http://www.finance.kerala.gov.in)  
Stock file/Office Copy (E-1032354)

Forwarded/By Order

  
Section Officer





GOVERNMENT OF KERALA

FINANCE (INDUSTRIES & PUBLIC WORKS-B) DEPARTMENT

**C I R C U L A R**

No.18/2019/Fin.

Dated, Thiruvananthapuram, 01.03.2019

Sub:- Procurement of Goods or Services or both or works by Government Departments, Public Sector Undertakings / Autonomous bodies or any agency of Government of Kerala in the context of GST – Clarification issued

Ref:- 1) Government Circular No. 90/2017/Fin dated 14.12.2017.  
2) Minutes of the meeting held by the Additional Chief Secretary (Finance) on 06.02.2019.

The Goods and Services Tax (GST) has come into effect in the State with effect from 1<sup>st</sup> July 2017. As per the Government Circular referred above, certain guidelines were issued regarding the applicability of GST on procurement of Goods, services and Public works arranged by various Government Departments and PSUs. Now, it has come to the notice of Government that certain points in the Circular require further elucidation to avoid ambiguity since the existing DSR and Cost Indices are inclusive of all taxes including VAT / GST and new SoR without tax component is yet to be published by CPWD.

**In the meeting held on 06.02.2019, it was observed that the base estimate shall be prepared based on rates devoid of GST. The GST shall**

**be added to the above base value. Also, TDS should be deducted on the base value.**

The Government after having examined the matter in detail, decided to issue following revised guidelines on GST for procurement of Goods and arrangement of services and public works by various Kerala Government Agencies, with immediate effect:-

1. In case of Public Works, for which estimates are prepared based on DSR (Delhi Schedule of Rates), the latest Cost of Indices published by PWD from time to time excluding the VAT / GST component is to be used for arriving estimate rates and it should be without GST Component(s) on the input/input services.
2. In the case of Non-DSR items also, the rate(s) taken for the input/input services should be exclusive of VAT/ GST Component.
3. The Public Works Department shall derive the applicable Cost Indices for various locations excluding the VAT/GST Component and upload in the PRICE software, in time.
4. All bidders for public works, goods and services should have valid GST Registration.
5. The rates quoted by the bidders shall include all taxes and duties Construction Workers Welfare Fund Contribution etc, except the GST.
6. While finalizing the procurement of Goods, Services or both or Public Works, the total amount of the estimates should be arrived exclusive of Goods and Service Tax (GST).
7. For the purpose of determining the lowest bidder (L1), the rates quoted by the bidders exclusive of GST amount should be taken into consideration.

8. For the purpose of issuing Administrative Sanction, the total amount for approval should indicate the estimate amount and GST applicable amounts separately.
9. When the bills for any goods, services or both or Public Works procured are processed, the payment has to be made to the contractor for the total value of the works at contract rates **PLUS** the applicable GST rate.
10. In case of change in the GST rate between the date of invoice and date of supply OR last date of submission of tender (in case of works), and the date of release of payment for works done, the prevailing GST Rate will be reckoned as per the GST laws of the Central and State Governments for payment.
11. Any variations in the tax rate of GST (increase or decrease) shall be adjusted at the time of bill processing i.e, deduction in the case of decrease in GST Rate or addition in case of increase in GST Rate shall be made at the time of settlement of bills.
12. The TDS and other deductions would be on payments made or credited to the supplier excluding GST.
13. The amount deducted as tax under the provisions of GST Act shall be paid into the Government by the deductor within **TEN** days after the end of month in which such deduction is made in the prescribed manner.
14. The deductor shall furnish to the deductee a certificate mentioning therein Contract value, rate of deduction, amount deducted, amount paid into Government in the prescribed manner.

The Circular read above modified to the above extent.

**MANOJ JOSHI IAS**  
**Additional Chief Secretary (Finance)**

To

The Principal Accountant General (A&E), Kerala, Thiruvananthapuram.  
The Principal Accountant General (G&SSA) Kerala Thiruvananthapuram.  
The Principal Accountant General (Audit) Kerala Thiruvananthapuram.  
The Principal Accountant General (E&RSA) Kerala, Thiruvananthapuram.  
All Heads of Departments and Offices  
The Nodal Officer, [www.finance.kerala.gov.in](http://www.finance.kerala.gov.in).  
Stock file E-735548 / Office Copy

Forwarded/By Order

  
Section Officer

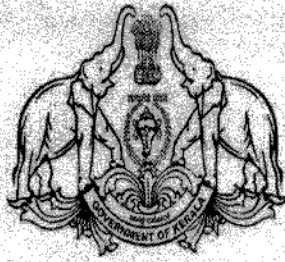

## GOVERNMENT OF KERALA

### Abstract

Finance Department – Covid - 19 pandemic - Relaxing the requirements of performance Security /Security Deposit, Bid Security/Earnest Money Deposit and Additional Performance Guarantee for the execution of public works in the State - Orders issued

### **FINANCE (INDUSTRIES & PUBLIC WORKS - B) DEPARTMENT**

G.O.(P) No.7/2021/Fin.

Dated, Thiruvananthapuram, 07.01.2021

- Read :-
- 1) G.O.(P) No.429/2015/Fin dated 28.09.2015
  - 2) G.O.(P) No. 01/2019 /Fin dated 10.01.2019
  - 3) G.O.(P) No.168/2019/Fin dated 07.12.2019
  - 4) OM No. F 18/4/2020 - PPD dated 13.05.2020
  - 5) OM No. F 9/4/2020 - PPD dated 12.11.2020
  - 6) Circular No.62/2020/Fin dated 27/10/2020

### ORDER

As per the Government Order read as 1<sup>st</sup> paper above, It was ordered that, Performance Guarantee , the amount collected at the time of executing contract agreement will be 5% of the Contract Value (Agreed PAC) and the deposit will be retained till the expiry of Defect Liability Period. Atleast 50% of this deposit shall be collected in the form of Treasury Fixed Deposit and rest in the form of Bank Guarantee or any other forms prescribed in the revised PWD Manual. As per this Government Order, Additional Performance Guarantee is the additional amount to be deposited for unbalanced price ie, for works quoted below estimate rate. Additional Performance Guarantee will be required if works quoted between 11% to 25% below estimate rate. Government Order read as 2nd paper above says that , if the quoted amount of the lowest bidder (L1) is x% below the estimated PAC, the Additional Performance Guarantee shall be (x-10)% of estimated PAC. Subsequent to this Order, clarifications were issued regarding calculation of Additional Performance Guarantee for percentage

rate contracts and item rate contracts vide the Government Order read as 3rd paper above.

2) On account of slow down in economy and acute financial crunch among the contractors due to COVID-19 pandemic, Government of India issued following guidelines vide Office Memoranda read as 4th and 5th papers above and State Governments were requested to consider issuing similar instructions in respect of procurement by the State Government, by State Government Public Undertakings, Local Bodies and all agencies controlled by them.

i) Reduction in Performance Security from existing 5-10% to 3% of the value of the contract.

ii) No provisions regarding Bid Security should be kept in the Bid Documents in future and only provisions for Bid Security Declaration should be kept in the Bid Documents.

iii) No provision should be kept in the Bid Documents regarding Additional Security Deposit/Bank Guarantee (BG) in case of Abnormally Low Bids.

3. As per the Circular read as 6th paper above, it was ordered that the Additional Performance Guarantee may be released in proportion of successful completion of items having low rates. Several contractors and Associations submitted representations requesting to extend the benefits covered by the relief measures announced by the Government of India to the State Government Contractors also.

4. Government have examined the matter in detail and are pleased to order as follows.

1) Performance Security / Security Deposit to be submitted at the time of executing the agreement is reduced from the existing rate of 5% to 3% of the contract amount.

2) Correspondingly Bid Security / Earnest Money Deposit is reduced from 2.50% to 1.50% of the estimated amount.

3) Additional Performance Guarantee is waived for the low quoted items on the condition that the bidder shall furnish an undertaking to execute all low quoted items in full as per contract terms.

5. The above relaxations on account of COVID -19 pandemic are made applicable for works initially for one year and would be reviewed post that date.

6. This Government Order is made applicable to all new tenders as well as works which have been tendered and awarded, but agreements have not been signed by the winning bidder.

**By Order of the Governor,  
RAJESH KUMAR SINGH  
ADDITIONAL CHIEF SECRETARY(Finance)**

To

The Accountant General (A&E) Kerala, Thiruvananthapuram  
The Accountant General (Audit II) Kerala, Thiruvananthapuram  
All Heads of Departments and Offices  
The Secretary to Governor  
All Departments of Secretariat  
All Private Secretaries to Ministers  
Private Secretary to Chief Minister  
Private Secretary to the Leader of Opposition  
All Secretaries to Government  
General Administration (SC) Department (Vide Item No. 4467 dated 06/01/2021)  
The Registrar, High Court of Kerala  
The Secretary, Kerala Human Rights Commission, Thiruvananthapuram  
The Election Commissioner, State Election Commission, Thiruvananthapuram  
The Registrar, University of Kerala/Cochin/Kozhikode/Kottayam  
The Nodal Officer, [www.finance.kerala.gov.in](http://www.finance.kerala.gov.in)  
Stock file/Office Copy (E-1633771)

Forwarded/By Order



Section Officer



## GOVERNMENT OF KERALA

### Abstract

Finance Department - Relaxation in Performance Guarantee for the execution of Public Works in the State - Extended - Orders issued.

### **FINANCE (INDUSTRIES & PUBLIC WORKS - B) DEPARTMENT**

**G.O.(P)No.32/2022/FIN**

**Dated, Thiruvananthapuram, 15-03-2022**

- Read :-
1. G.O(P)No. 429/2015/FIN dated 28.09.2015.
  2. Office Memorandum No. F9/4/2020-PPD dated 12/11/2020
  3. G.O(P)No. 7/2021/FIN dated 07.01.2021.
  4. Office Memorandum No. F 9/4/2020-PPD dated 30/12/2021

### **ORDER**

As per the Government Order read as 1<sup>st</sup> paper above, Performance Guarantee, the amount collected at the time of executing contract agreement will be 5% of the contract value (Agreed PAC). On account of slow down in economy and acute financial crunch among the contractors due to Covid 19 pandemic, Government of India as per Office Memorandum read as 2<sup>nd</sup> paper above, have reduced Performance Guarantee to be submitted at the time of executing contracts from the existing rate of 5-10% to 3% of the value of the contract. Subsequently Government of Kerala as per order read as 3<sup>rd</sup> paper above reduced the requirement of Performance Guarantee from 5% to 3% of the contract value for a period of one year.

2) Now Government of India as per Office Memorandum read as 4<sup>th</sup> paper above extended the validity of Office Memorandum dated 12/11/2020 for a period up to 31.03.2023. Consequently Government have received various requests to extend the benefits on reducing the rate of performance guarantee to contracts executed under the State of Kerala.



3) Government have examined the matter in detail and are pleased to extend the relaxations in Performance Guarantee ordered as per Government Order read as 3<sup>rd</sup> paper above for a further period up to 31/03/2023.

**This orders will have retrospective effect from 07/01/2022.**

(By Order of the Governor)  
**Rajesh Kumar Singh IAS**  
**Additional Chief Secretary (Finance)**

To

1. The Accountant General (A&E) Kerala, Thiruvananthapuram
2. The Accountant General (Audit-II) Kerala, Thiruvananthapuram
3. The Private Secretary to Hon'ble Chief Minister
4. All Private Secretaries to Hon'ble Ministers.
5. The Private Secretary to the Leader of Opposition.
6. The Secretary to Governor.
7. The Chief Secretary of Kerala.
8. All Secretaries to Government.
9. The Registrar, High Court of Kerala.
10. The Secretary, Kerala Human Rights Commission, Thiruvananthapuram.
11. The Election Commissioner, State Election Commission, TVPM.
12. All Departments of Secretariat.
13. All Heads of Departments/Offices
14. The Registrar, All Universities of Kerala.
15. The Chief Engineer [PWD/WRD/LSGD /HED]
16. The Chief Technical Examiner, Finance Department, Thiruvananthapuram
17. The Nodal Officer, [www.finance.kerala.gov.in](http://www.finance.kerala.gov.in)
18. Stock file/Office Copy(1967645)

Forwarded/By Order

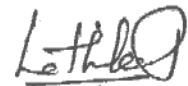

Section Officer



## GOVERNMENT OF KERALA

### Abstract

Public Works Department - Guidelines for trenching of PWD roads, laying of pipelines and their restoration by KWA - Sanction accorded - Orders issued.

---

### PUBLIC WORKS (H) DEPARTMENT

**G.O.(Ms)No.8/2022/PWD Dated,Thiruvananthapuram, 24-02-2022**

---

- Read: 1. G.O(Rt)No.30/2018/PWD dated 05.01.2018.  
2. G.O(Ms)No.444/2018/Fin dated 26.11.2018.  
3. Circular No.CE/R&B/GL-RC/2/2019 dated 30.03.2019 of the Chief Engineer, PWD, Roads.  
4. G.O(Rt)No.756/2019/PWD dated 20.06.2019.  
5. G.O(Ms)No.59/2020/PWD dated 30.07.2020.  
6. Circular No.CE/R&B/GL-RC/3/2018 dated 24.09.2020 of the Chief Engineer, PWD, Roads.  
7. Proceedings No.8665/AE3(MONITORING)/2020/KWA dated 19.11.2020 of the Managing Director, KWA.  
8. G.O(Ms)No.2/2021/WRD dated 06/01/2021.  
9. Circular No.H1/81/2021-PWD dated 03.07.2021.  
10. Minutes of the Meeting dated 05.01.2022 held by Hon'ble Min, PWD in the presence of Hon'ble Min, WRD to discuss the co-ordination between PWD & WRD.  
11. G.O(Rt)No.20/2022/PWD dated 07.01.2022.  
12. Minutes of the 1st Meeting of the Committee constituted for the co-ordination of works of PWD & WRD held on 18.01.2022.

### ORDER

The permissions for road cutting for laying various utilities are issued by PWD in accordance with the provisions of the PWD Manual and Highway Protection Act 1999. The Government Orders/Circulars

read above are presently in force regarding the guidelines for charging the restoration amounts and Security Deposits from the users. The laying of pipe lines by KWA in PWD roads and the consequent restoration of the roads is currently causing issues to both the Departments. Hence based on the Meetings held on 05.01.2022 and 18.01.2022 read as 10th and 12th paper above, it has been decided to issue particular direction regarding the trenching of PWD roads, laying of pipelines and their restoration by KWA in the light of the G.O read as 2nd paper above.

2. Government have examined the matter in detail and the following guidelines are issued hereby for road cutting and restoration for laying KWA pipe lines under PWD roads.

### **A. Utility Agency led Projects**

(i) KWA shall apply for road cuttings through the RoW portal in accordance with the G.O read as 5th paper above. The upcoming road works of both KWA and PWD shall be displayed in the RoW portal and updated regularly.

(ii) For urgent leakages and repairs also the permission has to be sought from PWD through the RoW portal. No deposit amount is required for cutting in non DLP roads for emergency leak rectification works. ( Repair work can be executed after intimating PWD in case of utmost emergency). Separate provision for sanction of emergency cases should be included in RoW portal.

(iii) In case of Utility laying works, KWA shall carry out the trenching, pipe laying, back filling and final restoration of the road surface. The road surface has to be restored to the same standards that was existing prior to trenching. Estimate of the restoration of roads shall be prepared by KWA in accordance with MoRTH specification and this will be included in the actual Utility laying/shifting/repair works.

(iv) In the case of leakages/repairs, KWA shall carry out road restoration done with plate compactors.

(v) The back filling of the trenches shall be carried out as per the CTE's direction in layers of 20cm thickness with roller/plate compactors for pipe laying works.

(vi) In the case of leakages/repairs, the back filling of the trenches shall be carried out in layers of 20cm thickness with plate compactors.

(vii) For the road restoration of pipe laying works, loosening and re-compacting for a depth of 30cm and provision of GSB and WMM with 15cm thick layers each should be included. The surfacing works should

be in accordance with the MORTH specifications and guidelines.

(viii)The work shall be carried out ensuring strict quality control and only with the supervision of PWD Engineers.

(ix)Minimum earth cushioning of 1.20m over the utility lines should be ensured

(x)As far as possible the laying of utility lines to be carried out through the shoulder portion and the alignment to be fixed through a joint inspection by both the Departments at EE level.

(xi)In case of road cutting and restoration works arranged by KWA in roads where resurfacing/upgradation works by PWD is scheduled, the restoration should be carried out excluding the provisions in the road work of PWD

(xii)A security deposit of 10% of the restoration amount required for the road cutting area to be remitted to PWD by KWA for the DLP existing roads, which will be released after the DLP of the restoration work and a tripartite agreement to be executed with PWD, KWA and the contractor who is carrying the work. Physical agreement keeping can be eliminated and the facility shall be made available/included in the online portal.

(xiii)All the quality control tests mentioned for road works in the Quality Manual of PWD to be carried out by KWA through accredited labs/institutions and the relevant test certificates to be submitted to PWD in the case of utility shifting/pipe laying.

(xiv)KWA shall submit the security deposit as above in the form of Treasury Savings Deposit/Bank Guarantee for obtaining sanction.

(xv)The time frame for completion of pipe laying and road restoration shall be specified in the permission letter and for delays/variations from the original sanctioned scope of trenching, the security deposit shall be forfeited proportionally.

(xvi)Display boards at site showing the details of work arranged by KWA with date of completion during execution and DLP details on completion of work should be erected.

(xvii)DLP conditions in accordance with existing PWD guidelines will be applicable for the restoration work done by KWA.

(xviii)The responsibility of the stretch handed over for trenching including safety arrangements and the maintenance during DLP of the restored portion shall vest with KWA limited to the length of the road where utility provider restored.

(xix)KWA shall take necessary steps to carry out the road cutting works, if any scheduled before arrangement of works by PWD.

(xx)In case of roads with existing DLP, the DLP responsibility of the road stretch where restoration is done will be vested with KWA.

(xxi)No road cutting will be permitted in roads which have been resurfaced for a period of one year from the date of completion of the work. Exemption may be granted on a case to case basis considering the importance like urgent leakage work, prestigious works, high priority works.

(xxii)For roads under DLP, beyond the first one year, the Executive Engineers, shall exercise powers to issue road cutting permit as mentioned in the G.O read as 5th paper above.

(xxiii)In the case of new bridge constructions, the provision for separate duct/platform for carrying the utilities shall be included in the design by PWD based on the requirement of user agency and the expenditure for the construction shall be met by the concerned agency.

(xxiv)In the case of existing bridges, the utilities already installed should be shifted in a phased time bound manner from the bridge by the user agency and separate provision for routing the same has to be made by the concerned agency.

### **B. PWD led Projects**

(i)PWD shall apply for utility shifting necessitated in road constructions through the RoW portal in accordance with the G.O read as 5th paper above. The upcoming road works of both KWA and PWD shall be displayed in the RoW portal and updated regularly.

(ii)While preparing the estimates for utility shifting by KWA for PWD led works the provisions should be same as that of the existing lines (ie.same dia of pipe, same material etc). The estimate for utility shifting shall be prepared by EE, KWA as per the G.O read as 8th paper above.

(iii)The estimate for utility shifting shall includes the works associated with pipe lines/sewer lines such as shifting/raising of valve chambers/manholes and all allied works.

(iv)The utility shifting/pipe laying works shall be supervised by KWA. The quality of works and quality of materials such as pipes/specials and allied materials shall be ascertained by KWA officials through site or factory test as is applicable.

(v)The Security Deposit for utility shifting (replacement of pipes) needs to be deposited by PWD.

(vi)A security deposit of 10% of the utility shifting amount required for replacement of pipes to be remitted to KWA by PWD for all pipe

shifting works, which will be released after the DLP of the pipes work and a tripartite agreement to be executed with PWD, KWA and the contractor who is carrying the work, the facility shall be included in the online portal.

(vii) PWD shall submit the security deposit as above in the form of Treasury Savings Deposit/Bank Guarantee for obtaining sanction.

(viii) The liability of leakages without obtaining sanction for utility shifting shall be borne by PWD.

(ix) The time frame for completion of pipe laying and road restoration shall be specified in the permission letter and for delays/variations from the original sanctioned scope of quality of pipes, design etc, the security deposit shall be forfeited proportionally.

(x) Display boards at site showing the details of work arranged by PWD with date of completion during execution and DLP details on completion of work should be erected.

(xi) In case where the utility shifting/pipe laying work is executed through the contractor for the PWD road work, the contractor shall be liable for any leakage/maintenance work during the DLP for the pipe laying work/road restoration work associated during the maintenance period or upto the date of handing over the utility to KWA, not to exceed six months after the completion of the work.

### **C. General**

(i) While preparing the estimates for new road constructions the provisions for utility ducts to be included in consultation with the utility providers based on their requirement if there is ample PWD land available for such works. In the case of existing roads the additional provisions for utility ducts shall be explored.

(ii) The committee constituted as per the G.O read as 11th paper above shall consider the major disputes arised, if any, between both the Departments and the decision of this committee will be treated as final.

(By order of the Governor)  
**ANAND SINGH**  
**SECRETARY**

To,

All Chief Engineers, PWD, Thiruvananthapuram.

All Executive Engineers of PWD (Through Chief Engineers).

The Managing Director, Kerala Water Authority, Tvpm.  
The Chief Executive Officer, Kerala Road Fund Board, Tvpm.  
Water Resources Department.  
Stock File/ Office Copy/ Website

Forwarded /By order

Section Officer

Copy to:PS to Minister, PWD.  
PS to Minister, WRD.  
PA to Secretary, PWD.  
PA to Joint Secretary, PWD.



**GOVERNMENT OF KERALA**

**Abstract**

Water Resources Department - Kerala Rural Water Supply and Sanitation Agency - Implementation of the Scheme " Sustainability Support to Community Managed Water Supply Schemes under State Plan Scheme 2022-23 - Administrative Sanction accorded - Orders Issued

**Water Resources (Water Supply - B) Department**

G.O.(Rt)No.837/2022/WRD Dated,Thiruvananthapuram, 17-09-2022

Read 1 Letter No. KRWSA-PMU/155/2022-TA(Tech) dated 02/08/2022.

2 Minutes of the Departmental Working Group held on 20/08/2022.

**ORDER**

In the current year's budget an amount of ₹30 crore has been earmarked under Head of Account 2215-01-102-80(P)- V for Sustainability Support to Community Managed Water Supply Schemes. The Executive Director, Kerala Rural Water Supply and Sanitation Agency (KRWSA) as per the letter read above has submitted following proposal amounting to ₹10 Crore for consideration of the Departmental Working Group.

**Sustainability Support to Community Managed Water Supply Schemes in RPMU, Malappuram District**

Total Budget allocation for 2022-23 : ₹30 Crores

Head of Account : 2215-01-102-80-Plan

Administrative Sanction sought for : ₹10 Crore

Sl. No.	Name of Component  Item	Estimate		Administrative sanction requested  (in Lakhs)	Remarks
		Physical Target  (Nos.)	Financial Target  (in Rs)		
	<b>Sustainability Support to Community Managed Water Supply Schemes</b>				
	Restoration of 100				



	partially/fully defunct community managed drinking water supply schemes under the jurisdiction of RPMU Malappuram implemented in rural water sector including Jalanidhi in 30 GPs of the state to ensure safe drinking water to 12179 households.	100 schemes	8,40,00,000	840.00	
	<b>Subtotal</b>		<b>8,40,00,000</b>	<b>840.00</b>	
b	Capacity building & IEC to enable the stakeholders for effective and efficient management of the assets rehabilitated.	12 Months	5,33,333	5.33	
c	Prepare a database of Community managed small water supply infra structure	12 Months	3,00,000	3.00	
d	Repositioning of KRWSA as a back stopping support agency for community managed water supply systems	12 Months	1,66,667	1.67	
e	Administrative expenses	12 Months	15,00,000	150.00	
	<b>TOTAL</b>		<b>10,00,00,000</b>	<b>1000.00</b>	

**Note : 100% of estimate cost of restoration works of water supply scheme will be borne by Government of Kerala. The project envisages to setup a revolving fund mechanism by collecting additional 15 % of project cost from the Grama Panchayats and beneficiary groups. The Grama Panchayats will contribute 5% of the project cost and 10% by the beneficiary group. (The SC/ST/Fisherman community will contribute 5% of**

the total project cost). The GP share (5%) and beneficiary share (10%) will be deposited in the joint bank account managed by Grama Panchayat President & Secretary and shall utilize this amount as revolving fund for the Operation & Maintenance of drinking water supply in GP. Administrative Sanction requested for restoration works of WSS, Capacity building, IEC, preparation of data base for community managed water supply scheme, under RPMU Malappuram of KRWSA as backstopping support to community managed water supply schemes & Administrative expenses is ₹10,00,00,000/-.

2.The Departmental Working Group held on 20/08/2022 approved the proposal.

3. Government have examined the matter in detail and are pleased to accord Administrative Sanction for a total amount of ₹10 Crore (Rupees Ten Crore Only) for the implementation of the project as detailed above. The expenditure will be debited under the Head of Account 2215-01-102-80(P).

(By order of the Governor)  
D SANTHOSH  
ADDITIONAL SECRETARY

To:

The Executive Director, Jalanidhi  
The Principal Accountant General (A&E/Audit), Kerala  
The Finance Department  
I&PR (Web & New Media) Department  
Stock File/ Office Copy.

Forwarded /By order

  
Section Officer



കേരള ഗ്രാമീണ ശുദ്ധജല വിതരണ ശുചിത്വ പദ്ധതി

പി . ടി .സി ടവേഴ്സ് , 3<sup>rd</sup> ഫ്ലോർ, എസ്.എസ്. കോവിൽ റോഡ്, തമ്പാനൂർ, തിരുവനന്തപുരം -695001  
ഫോൺ: 2337002,3,5 ഫാക്സ് : 2337004  
Email: dopjalanidhi@gmail.com  
www.jalanidhi.kerala.gov.in

KRWSA-PMU/36/2018-TA (OP)-Part(1)

15/10/2022

പ്രേഷിതൻ

എക്സിക്യൂട്ടീവ് ഡയറക്ടർ

സ്വീകർത്താവ്

റിജിയണൽ പ്രോജക്ട് ഡയറക്ടർ  
കണ്ണൂർ / മലപ്പുറം / ഇടുക്കി RPMU

സർ,

വിഷയം :-

പ്ലാൻ പദ്ധതി - 2022-23 - നിർവ്വഹണ മാർഗ്ഗരേഖ സംബന്ധിച്ചു

സൂചന :-

- 1) GO(Rt) No. 837/ 2022/ WRD dated 17.09.22
- 2) GO(Rt) No. 838/ 2022/ WRD dated 17.09.22
- 3) GO(Rt) No. 839/ 2022/ WRD dated 17.09.22
- 5) GO(Rt) No. 848/ 2022/ WRD dated 20.09.22
- 6) GO(Rt) No. 849/ 2022/ WRD dated 20.09.22
- 7) GO(Rt) No. 850/ 2022/ WRD dated 20.09.22
- 8) GO(Rt) No. 851/ 2022/ WRD dated 20.09.22
- 9) GO(Rt) No. 852/ 2022/ WRD dated 20.09.22

KRWSA മുഖേന 2022-2023 സാമ്പത്തിക വർഷത്തിൽ നടപ്പിലാക്കുന്ന വിവിധ പദ്ധതികൾക്ക് സർക്കാരിൽ നിന്നും മേൽ സൂചന പ്രകാരം ലഭിച്ച ഭരണാനുമതികളിലേക്ക് ശ്രദ്ധ ക്ഷണിക്കുന്നു. വിവിധ പദ്ധതികളുടെ നിർവ്വഹണത്തിനു വേണ്ടി തെയ്യാറാക്കിയ നിർവ്വഹണ മാർഗ്ഗരേഖ ഇതോടൊപ്പം ഉള്ളടക്കം ചെയ്തിട്ടുണ്ട്. ഈ സാമ്പത്തിക വർഷത്തിൽ അനുമതി ലഭിച്ച എല്ലാ പദ്ധതികളും സമയബന്ധിതമായി പൂർത്തീകരിക്കുന്നതിനുള്ള നടപടികൾ സ്വീകരിക്കണം എന്ന് അറിയിക്കുന്നു..

വിശ്വസ്തതയോടെ  
Signature valid  
Digitally signed by Veena P  
Date: 2022.10.15 14:07:53 IST  
Reason: Approved  
ഡയറക്ടർ ഫിനാൻസ് & അഡ്മിസ്ട്രേഷൻ (i/c)  
എക്സിക്യൂട്ടീവ് ഡയറക്ടർക്ക് വേണ്ടി

പകർപ്പ്

- 1. എല്ലാ ഡയറക്ടർമാർക്കും, ഡെപ്യൂട്ടി ഡയറക്ടർമാർക്കും



I/20214/2022

**കേരള ഗ്രാമീണ ശുദ്ധജലവിതരണ ശുചിത്വ ഏജൻസി (KRWSA)**

**2022-2023 മുതലുള്ള പ്ലാൻ ഫണ്ട് വിനിയോഗം - പുതുക്കിയ നിർവ്വഹണ മാർഗ്ഗരേഖ**

കേരള സംസ്ഥാന ജലവിഭവ വകുപ്പിനു കീഴിൽ പങ്കാളിത്താധിഷ്ഠിത ഗ്രാമീണ ശുദ്ധജലവിതരണ ശുചിത്വ പദ്ധതികൾ (ജലനീഡി) നടപ്പിലാക്കുന്നതിനു വേണ്ടി സംസ്ഥാന സർക്കാർ രൂപം കൊടുത്ത സ്ഥാപനമാണ് കേരള ഗ്രാമീണ ശുദ്ധജലവിതരണ ശുചിത്വ ഏജൻസി (KRWSA).സാമൂഹ്യ ഉടമസ്ഥതയിലുള്ള കുടിവെള്ള വിതരണ പദ്ധതികളുടെ പുനരുദ്ധാരണവും നവീകരണവും ലക്ഷ്യമിട്ട് 2018-19 മുതൽ സംസ്ഥാന സർക്കാർ sustainability support to community managed water supply scheme എന്ന പേരിൽ ഒരു പദ്ധതി ആരംഭിക്കുകയും അതിന്റെ നിർവ്വഹണ ഏജൻസിയായി KRWSA യെ ചുമതലപ്പെടുത്തുകയും ചെയ്തു.അതുപ്രകാരം സംസ്ഥാന സർക്കാരിന്റെ പ്ലാൻ ഫണ്ട് ഉപയോഗിച്ച് കഴിഞ്ഞ 3 സാമ്പത്തിക വർഷമായി സാമൂഹ്യ ഉടമസ്ഥതയിലുള്ള കുടിവെള്ള വിതരണ പദ്ധതികളുടെ നവീകരണ പ്രവർത്തനങ്ങൾ KRWSA നടത്തി വരുന്നു. 2022-2023 സാമ്പത്തിക വർഷം മുതൽ വിവിധ പ്ലാൻ ഹെഡുകളിൽ ഉൾപ്പെടുത്തി താഴെ പറയുന്ന പ്രവർത്തനങ്ങൾ കൂടി നടപ്പിലാക്കുന്നതിന് സംസ്ഥാന സർക്കാർ KRWSA യെ ചുമതലപ്പെടുത്തി തീരുമാനിച്ചതിന്റെ പശ്ചാത്തലത്തിൽ 2022-23 മുതൽ അനുവദിച്ചിട്ടുള്ള മുഴുവൻ പ്രവർത്തനങ്ങൾക്കും ബാധകമാകാവുന്ന തരത്തിലുള്ള പുതുക്കിയ നിർവ്വഹണ മാർഗ്ഗരേഖ ചുവടെ നൽകുന്നു.

ക്രമ നം.	പദ്ധതി ഘടകം	പ്ലാൻ ഹെഡ്
1	സുസ്ഥിരത പദ്ധതി (കുടിവെള്ള വിതരണ പദ്ധതികളുടെ പുനരുദ്ധാരണ നവീകരണ പ്രവൃത്തികൾ )	2215-01-102-80 (P)
2	ജലഗുണനിലവാരം മെച്ചപ്പെടുത്തൽ, ഗ്രേ വാട്ടർ മാനേജ്മെന്റ്	4215-02-102-99 (P)
3	ഗാർഹിക കിണറുകളെ സംരക്ഷിതവും സുസ്ഥിരവുമായ കുടിവെള്ള സ്രോതസ്സുകളാക്കി മാറ്റുന്ന പ്രവൃത്തികൾ	4215-01-800-85 (P)
4	മഴവെള്ള സംഭരണം, ഭൂജല റീചാർജ്ജ് പ്രവർത്തനങ്ങൾ (RWH & GWR)	2215-01-800-64 (P)
5	ഐഇസി, കാര്യശേഷി വർദ്ധിപ്പിക്കൽ പരിശീലനം,ജലശ്രീ ക്ലബ്ബ്	2215-01-003-99 (P)
6	ഗ്രാമീണ ജല സാങ്കേതിക വിദ്യകളിലെ ഗവേഷണവും വികസനവും	4215-01-800-84 (P)

**പദ്ധതി ഘടകങ്ങളും ചെലവ് പങ്കിടലും**

ക്രമ നം.	പദ്ധതി ഘടകം	ചെലവ് പങ്കിടൽ		
		ഗ്രാമപഞ്ചായത്ത് വിഹിതം (%)	ഗുണഭോക്തൃ വിഹിതം(%)	സർക്കാർ വിഹിതം(%)
1	സുസ്ഥിരത പദ്ധതി (കുടിവെള്ള വിതരണ പദ്ധതികളുടെ പുനരുദ്ധാരണ നവീകരണ പ്രവൃത്തികൾ)	5*	10*	100
2	ജലഗുണനിലവാരം മെച്ചപ്പെടുത്തൽ, ഗ്രേ വാട്ടർ മാനേജ്മെന്റ്	0	0	100
3	ഗാർഹിക കിണറുകളെ സംരക്ഷിതവും സുസ്ഥിരവുമായ കുടിവെള്ള സ്രോതസ്സുകളാക്കി മാറ്റുന്ന പ്രവൃത്തികൾ.	0	0	100

I/20214/2022

4	മഴവെള്ള സംഭരണം, ഭൂജല റീചാർജ്ജ് പ്രവർത്തികൾ (RWH &GWR)	0	10*	100
5	ഐഇസി, കാര്യശേഷി വർദ്ധിപ്പിക്കൽ പരിശീലനം,ജലശ്രീ ക്ലബ്ബ്	0	0	100
6	ഗ്രാമീണ ജല സാങ്കേതിക വിദ്യകളിലെ ഗവേഷണവും വികസനവും.	0	0	100

സുസ്ഥിരത പദ്ധതിയിൽ പട്ടിക ജാതി/ പട്ടിക വർഗ്ഗ / മത്സ്യത്തൊഴിലാളി വിഭാഗങ്ങളിൽ ഉൾപ്പെട്ടവർ ഗുണഭോക്തൃ വിഹിതം 5% മറ്റുവിഭാഗത്തിലുൾപ്പെട്ടവർ 10% എന്നീ ക്രമത്തിലാണ് എടുക്കേണ്ടത്. വ്യക്തിഗത ഗുണഭോക്താക്കൾക്ക് മഴവെള്ള സംഭരണികൾ നിർമ്മിച്ചു നൽകുന്ന പദ്ധതിയിൽ ഉൾപ്പെട്ട പട്ടിക ജാതി/ പട്ടിക വർഗ്ഗ / മത്സ്യത്തൊഴിലാളി/ ബീപിഎൽ ഗുണഭോക്താക്കൾ ടി പദ്ധതിക്ക് ഗുണഭോക്തൃവിഹിതം നൽകേണ്ടതില്ല. മേൽ വിഭാഗത്തിൽ ഉൾപ്പെട്ടവരുടെ അപേക്ഷ സംബന്ധിച്ചുള്ള വിശദമായ പരിശോധന വേളയിൽ പുരപ്പറഞ്ഞുനിന്നും മഴവെള്ളം ശേഖരിച്ച് വീടിനു സമീപം മഴവെള്ള സംഭരണി നിർമ്മിക്കുവാൻ സാഹചര്യം ഇല്ല എങ്കിൽ മാത്രം APL കുടുംബങ്ങളെ പദ്ധതി ഗുണഭോക്താവായി തിരഞ്ഞെടുക്കാവുന്നതാണ്. APL വിഭാഗത്തിൽ ഉൾപ്പെട്ടവരാണ് ഗുണഭോക്താക്കളിൽ 10% ഗുണഭോക്തൃ വിഹിതം എടുക്കേണ്ടതാണ്.സർക്കാർ സ്ഥാപനങ്ങളിലും പൊതു ഇടങ്ങളിലും നടപ്പിലാക്കുന്ന പ്രവൃത്തികൾക്ക് ഗുണഭോക്തൃ വിഹിതം ആവശ്യമില്ല.

**പദ്ധതി പങ്കാളികൾ**

ക്രമ നം	പദ്ധതി ഘടകം	പങ്കാളികൾ
1	സുസ്ഥിരത പദ്ധതി (കടിവെള്ള വിതരണ പദ്ധതികളുടെ പുനരുദ്ധാരണ നവീകരണ പ്രവൃത്തികൾ	ഗ്രാമപഞ്ചായത്ത്, KRWSA, ഗുണഭോക്തൃ സമിതി
2	ജലഗുണനിലവാരം മെച്ചപ്പെടുത്തൽ, ഗ്രേ വാട്ടർ മാനേജ്മെന്റ്	ഗ്രാമപഞ്ചായത്ത്, KRWSA, ഗുണഭോക്തൃ സമിതി/സ്ഥാപനങ്ങൾ
3	ഗാർഹിക കിണറുകളെ സംരക്ഷിതവും സുസ്ഥിരവുമായ കടിവെള്ള സ്രോതസ്സുകളാക്കി മാറ്റുന്ന പ്രവൃത്തികൾ.	ഗ്രാമപഞ്ചായത്ത്, KRWSA, ഗുണഭോക്താക്കൾ/സമിതി
4	മഴവെള്ള സംഭരണം, ഭൂഗർഭജല റീചാർജ്ജ് പ്രവൃത്തികൾ (RWH &GWR)	ഗ്രാമപഞ്ചായത്ത്, KRWSA, ഗുണഭോക്താക്കൾ/സമിതി

**കെ.ആർ.ഡബ്ല്യു.എസ്.എ.യുടെ ഉത്തരവാദിത്വങ്ങളും ചുമതലകളും**

1. പദ്ധതികൾക്കുള്ള ഭരണാനുമതി സർക്കാരിൽ നിന്നും ലഭ്യമാക്കുക.
2. പദ്ധതികളുടെ സമയബന്ധിതവും ഫലപ്രദവുമായ പൂർത്തീകരണത്തിനാവശ്യമായ നയപരമായ തീരുമാനങ്ങളെടുക്കുക.
3. പദ്ധതി നിർവ്വഹണ മാർഗരേഖകൾ, മാനദണ്ഡങ്ങൾ, തുടർ നടത്തിപ്പ് മാർഗ്ഗരേഖ എന്നിവ സമയാസമയങ്ങളിൽ പുന:പരിശോധിച്ച് ആവശ്യമെങ്കിൽ വേണ്ട മാറ്റങ്ങൾ വരുത്തുക.
4. വിവിധ പദ്ധതികളുടെ നിർവഹണവുമായി ബന്ധപ്പെട്ട ഗ്രാമപഞ്ചായത്തുകൾ നൽകുന്ന ലിസ്റ്റിൽ നിന്നും ആവശ്യമായ സാമൂഹ്യ-സാങ്കേതിക പരിശോധന നടത്തി സുസ്ഥിരതാ പദ്ധതി സ്കീമുകളുടെയും മറ്റു പദ്ധതികളിലെ ഗുണഭോക്താക്കളുടെയും ലിസ്റ്റ് തയ്യാറാക്കി

I/20214/2022

ഗ്രാമപഞ്ചായത്തിന് നൽകുക.

5. കെ.ആർ.ഡബ്ല്യു.എസ്.എയുടെ സാങ്കേതിക ഉദ്യോഗസ്ഥർ മുഖേന തയ്യാറാക്കുന്ന വിവിധ പ്രവൃത്തികളുടെ എസ്കീമോകൾക്ക് സാങ്കേതികാനുമതി നൽകുക.
6. പദ്ധതികളുടെ സമയബന്ധിതവും സുഗമവുമായ നിർവ്വഹണത്തിനായി പദ്ധതിപങ്കാളികൾക്ക് വേണ്ട നിർദ്ദേശങ്ങളും പിന്തുണയും നൽകുക . സർക്കാർ, സർക്കാരിതര ഏജൻസികൾ, മറ്റു സമാന ഏജൻസികൾ , സ്ഥാപനങ്ങൾ എന്നിവരുമായി സഹകരിച്ച് പ്രവർത്തിക്കുക.
7. പദ്ധതികൾ നടപ്പിലാക്കുന്നതിനായി കെ.ആർ.ഡബ്ല്യു.എസ്.എയുടെ ഉദ്യോഗസ്ഥരെ പഞ്ചായത്തുകളുടെ ചുമതല നൽകി നിയമിക്കുക. KRWSA നിയോഗിക്കുന്ന ഉദ്യോഗസ്ഥർക്ക് ബെനിഫിഷ്യറി ഗ്രൂപ്പ് (BG), സ്കീം ലെവൽ എക്സിക്യൂട്ടീവ് കമ്മിറ്റി (SLEC), ഗ്രാമപഞ്ചായത്ത് ലെവൽ ആക്ടിവിറ്റി കമ്മിറ്റി (GPLAC), ഗ്രാമപഞ്ചായത്ത്(GP) എന്നിവരുടെ പദ്ധതിയുമായി ബന്ധപ്പെട്ട രേഖകൾ , അക്കൗണ്ടുകൾ എന്നിവ പരിശോധിക്കുക.
8. പ്രൊജക്ട് ഫണ്ട് യഥാസമയം നൽകുക.
9. പദ്ധതിയുമായി ബന്ധപ്പെട്ട് KRWSA നൽകിയിട്ടുള്ള മാർഗ്ഗ നിർദ്ദേശങ്ങൾക്കും നിയമങ്ങൾക്കും വിരുദ്ധമായി ഏതെങ്കിലും പങ്കാളികൾ പ്രവർത്തിച്ചു എന്ന് ബോധ്യപ്പെട്ടാൽ അവർക്കെതിരെ നടപടി സ്വീകരിക്കുകയും പ്രൊജക്ട് ഫണ്ട് നൽകുന്നത് നിറുത്തി വെക്കുകയും ചെയ്യുക.
10. ഗ്രാമപഞ്ചായത്ത് ഭരണസമിതി അംഗങ്ങൾ, ഉദ്യോഗസ്ഥർ, പദ്ധതിയുമായി ബന്ധപ്പെട്ട പ്രവൃത്തിക്കുന്ന വിവിധ വകുപ്പുകളിലെ ഉദ്യോഗസ്ഥർ, ഗ്രാമപഞ്ചായത്ത് ലെവൽ ആക്ഷൻ കമ്മിറ്റി അംഗങ്ങൾ, ഗുണഭോക്തൃസമിതി അംഗങ്ങൾ, ഗുണഭോക്താക്കൾ, മറ്റ് സന്നദ്ധ സംഘടനകൾ, അധ്യാപകർ, വിദ്യാർത്ഥികൾ, സാമൂഹ്യ പ്രവർത്തകർ , കുടുംബശ്രീ പ്രവർത്തകർ എന്നിവർക്ക് ആവശ്യമായ പരിശീലനം നൽകുക.
11. പദ്ധതികൾ സുഗമവും സമയബന്ധിതവുമായി നടപ്പിലാക്കുന്നതിനു വേണ്ടി നിശ്ചിത തുടരവേളകളിൽ പദ്ധതി പുരോഗതിയുടെ നിരീക്ഷണവും അവലോകനവും നടത്തുക. എല്ലാ പദ്ധതി പങ്കാളികളെയും പങ്കെടുപ്പിച്ചുകൊണ്ടുള്ള അവലോകന യോഗങ്ങൾ നടത്തുക. എല്ലാ പങ്കാളികൾക്കും ഉദ്യോഗസ്ഥർക്കും സംഘടകർക്കും പദ്ധതി നടത്തിപ്പിനു വേണ്ട മാർഗനിർദ്ദേശം, സഹായം, ഉപദേശം എന്നിവ നൽകുക. പദ്ധതിയുടെ പുരോഗതി ഉറപ്പുവരുത്തുന്നതിന് KRWSA യുടെ ഉദ്യോഗസ്ഥർ നിരന്തരം ഗുണഭോക്തൃസമിതികൾ, സ്കീമുകൾ, പ്രവർത്തന കേന്ദ്രങ്ങൾ എന്നിവ സന്ദർശിക്കുക.
12. പദ്ധതി അടങ്കലിന് അനുസൃതമായി നടപ്പിലാക്കുന്ന പ്രവർത്തികളുടെ അളവുകൾ രേഖപ്പെടുത്തി മൂല്യനിർണയം ചെയ്ത് അംഗീകരിക്കുക. ഓഡിറ്റിംഗുകൾ നടത്തുക.
13. പദ്ധതി നിർവ്വഹണ പ്രവൃത്തികൾ/ സേവനങ്ങൾ എന്നിവയുടെ ഗുണനിലവാരം ഉറപ്പു വരുത്തുക.
14. പ്രവൃത്തികൾ പൂർത്തീകരിച്ചതിനു ശേഷം പദ്ധതി പൂർത്തീകരണ രേഖ തയ്യാറാക്കുന്നതിന് BG /SLEC /GPLAC എന്നിവരെ സഹായിക്കുക. ഇവ പരിശോധിച്ച്, അംഗീകരിച്ചതിന് ശേഷം ബന്ധപ്പെട്ട സമിതികൾക്കും , ഗ്രാമപഞ്ചായത്തിനും പൂർത്തീകരണ രേഖയുടെ പകർപ്പുകൾ നൽകുക.
15. പുനരുദ്ധരിച്ച/പുനസ്ഥാപിച്ച/നടപ്പിലാക്കിയ സ്കീമുകൾ പ്രവർത്തനക്ഷമാണെന്ന് ഉറപ്പുവരുത്തി തുടർനടത്തിപ്പിനും പരിപാലനത്തിനുമായി കൈമാറുക.
16. തദ്ദേശ സ്വയംഭരണ സ്ഥാപനങ്ങൾ/ സമിതികൾ/സംഘടനകൾ/മറ്റ് സ്ഥാപനങ്ങൾ ആവശ്യപ്പെടുന്നതനുസരിച്ച് KRWSA നിശ്ചയിക്കുന്ന നിരക്കിൽ സാങ്കേതിക-മാനേജ്മെന്റ് സഹായങ്ങൾ പദ്ധതികളുടെ തുടർപരിപാലനത്തിന് നൽകുക .
17. സർക്കാർ കാലാകാലങ്ങളിൽ ഏൽപ്പിക്കുന്ന മറ്റ് പദ്ധതികളുടെ നിർവ്വഹണം നടത്തുക.

**ഗ്രാമപഞ്ചായത്തിന്റെ ഉത്തരവാദിത്വങ്ങളും ചുമതലകളും.**

1. പദ്ധതികൾ നടപ്പിലാക്കുന്നതിനുള്ള ഗ്രാമപഞ്ചായത്ത് തീരുമാനം എടുക്കുക.
2. സുസ്ഥിരതാ പദ്ധതിയിൽ ഏറ്റെടുത്ത് നിർവ്വഹണ പ്രവർത്തനങ്ങൾ നടത്തേണ്ട പദ്ധതികളുടെ ലിസ്റ്റ് നൽകുക.
3. വ്യക്തിഗത പദ്ധതികളിലെ ഗുണഭോക്താക്കളുടെ മുൻഗണനാ ലിസ്റ്റ് തയ്യാറാക്കി

I/20214/2022

നൽകുക. ആവശ്യമായ സാമൂഹ്യ-സാങ്കേതിക പരിശോധനകൾക്ക് ശേഷം ടി ലിസ്റ്റിൽ നിന്നും കെ.ആർ.ഡബ്ല്യു.എസ്.എ തയ്യാറാക്കി നൽകുന്ന ലിസ്റ്റ് പരിശോധിച്ച അംഗീകാരം നൽകുക.

4. കടിവെള്ള വിതരണ പദ്ധതികളുടെ പുനരുദ്ധാരണ നവീകരണ പ്രവർത്തനങ്ങൾക്ക് വേണ്ടി വരുന്ന ചെലവിന്റെ 5% വിഹിതം ഗ്രാമപഞ്ചായത്ത് വിഹിതമായി നൽകുക.
5. ഗുണഭോക്തൃസമിതികൾ/ ഗുണഭോക്താക്കൾ/ സ്ഥാപനങ്ങൾ എന്നിവരുടെ പ്രതിനിധികളെ ഉൾപ്പെടുത്തി പദ്ധതി നിർവ്വഹണത്തിനുവേണ്ടി രൂപീകരിക്കുന്ന ഗ്രാമപഞ്ചായത്ത് ലെവൽ ആക്ടിവിറ്റി കമ്മിറ്റി (GPLAC)യെ അംഗീകരിക്കുക. അവർക്ക് ബാങ്ക് അക്കൗണ്ട്, മറ്റു രജിസ്ട്രേഷനുകൾ എന്നിവ ആവശ്യമാണെങ്കിൽ ആയത് ആരംഭിക്കുന്നതിനു വേണ്ടി തിരുമാനങ്ങൾ നൽകുക.
6. പദ്ധതി നിർവ്വഹണവുമായി ബന്ധപ്പെട്ട ഗുണഭോക്തൃസമിതികൾ/എസ്.എൽ.ഇ.സി./സ്ഥാപനങ്ങൾ/GPLAC എന്നിവരുമായി KRWSA നിർദ്ദേശപ്രകാരം കരാറുകൾ ഒപ്പിടുക.
7. വിവിധ ഏജൻസികൾ പദ്ധതിയുമായി ബന്ധപ്പെട്ട നടത്തുന്ന ഓഡിറ്റിംഗ് , വിലയിരുത്തൽ എന്നിവയുമായി സഹകരിക്കുക.
8. പദ്ധതി നടത്തിപ്പിന് ആവശ്യമായ സഹായസഹകരണവും പിന്തുണയും അനുമതികളും തിരുമാനങ്ങളും KRWSA യ്ക്കും, KRWSA നിർദ്ദേശിക്കുന്ന മറ്റ് പദ്ധതി പങ്കാളികൾക്കും നൽകുക.
9. സുസ്ഥിരതാ പദ്ധതിയിൽ ഏറ്റെടുത്ത് പ്രവൃത്തികൾ പൂർത്തീകരിക്കുന്ന എല്ലാ കടിവെള്ള വിതരണ പദ്ധതികളുടെയും ആസ്തികൾ ഗ്രാമപഞ്ചായത്തിന്റെയും അതാത് സമിതികളുടെയും സംയുക്ത ഉടമസ്ഥതയിൽ ആക്കുന്നതിനുള്ള നടപടികൾ സ്വീകരിക്കുക.
10. സാമൂഹ്യ ഉടമസ്ഥതയിൽ പ്രവർത്തിക്കുന്ന കടിവെള്ള വിതരണ പദ്ധതികളുടെ ഗുണഭോക്തൃസമിതികളുടെ ഫെഡറേഷൻ (ബി.ജി. ഫെഡറേഷൻ) രൂപീകരിക്കുക.പദ്ധതികളുടെ കാര്യക്ഷമമായ തുടർ നടത്തിപ്പിനും ,തർക്ക പരിഹാരത്തിനും,നൂതനാശയങ്ങൾ നടപ്പിലാക്കുന്നതിനുമുള്ള ശക്തമായ ഒരു സംവിധാനമായി ബി.ജി. ഫെഡറേഷനെ പ്രവർത്തിപ്പിക്കുക.
11. ഗ്രാമപഞ്ചായത്ത് പ്രസിഡന്റ് ബി.ജി. ഫെഡറേഷന്റെയും പ്രസിഡന്റ് ആയിരിക്കും. ഗ്രാമപഞ്ചായത്ത് സെക്രട്ടറി, മറ്റ് ഗ്രാമപഞ്ചായത്ത് അംഗങ്ങൾ എന്നിവർ എക്സിക്യൂട്ടീവ് കമ്മിറ്റിയിൽ അംഗങ്ങളായിരിക്കും.ഓരോ ഗുണഭോക്തൃ സമിതിയിൽ നിന്നും, സ്ത്രീ- ചെലവ് എക്സിക്യൂട്ടീവ് കമ്മിറ്റി (SLEC) ഉള്ള സ്ഥലങ്ങളിൽ അതിൽ നിന്നും 2 പേരെ വീതം ബി.ജി. ഫെഡറേഷനിൽ ഉൾപ്പെടുത്തണം. പ്രസിഡന്റിന്റെ അധ്യക്ഷതയിൽ പൊതുയോഗം ചേർന്ന് BG,SLEC എന്നിവയിൽ നിന്നും ഉള്ളവരെ മാത്രം ഉൾപ്പെടുത്തി ഫെഡറേഷന്റെ ഭാരവാഹികളെയും എക്സിക്യൂട്ടീവ് കമ്മിറ്റിയെയും തിരഞ്ഞെടുക്കുക.
12. KRWSA മുഖേന നടപ്പിലാക്കിയ ജലനിധി പദ്ധതി അടക്കമുള്ള പദ്ധതികളുടെ തുടർ നടത്തിപ്പും പരിപാലനവും ശരിയായ ദിശയിൽ മുന്നോട്ട് കൊണ്ടുപോകുന്നതിനും, അവലോകനം ചെയ്യുന്നതിനും, BG ഫെഡറേഷൻ യോഗത്തിരുമാനങ്ങൾ ചർച്ച ചെയ്ത് അതിന്മേൽ മാർഗ്ഗനിർദ്ദേശങ്ങൾ, സഹായക പ്രവർത്തനങ്ങൾ എന്നിവ നൽകുന്നതിനും വേണ്ടി പഞ്ചായത്ത് തല മോണിറ്ററിംഗ് കമ്മിറ്റി രൂപീകരിക്കുക.
13. ഗ്രാമപഞ്ചായത്ത് പ്രസിഡന്റ്, ആരോഗ്യ-വിദ്യാഭ്യാസ സ്റ്റാന്റിംഗ് കമ്മിറ്റി ചെയർമാൻ, ഗ്രാമപഞ്ചായത്ത് സെക്രട്ടറി, KRWSA പ്രതിനിധി, ഗുണഭോക്തൃ സമിതികളുടെ ഫെഡറേഷന്റെ വൈസ് പ്രസിഡന്റ്, സെക്രട്ടറി എന്നിവരെ ഉൾപ്പെടുത്തിയാണ് മോണിറ്ററിംഗ് കമ്മിറ്റി രൂപീകരിക്കേണ്ടത്.
14. ഗുണഭോക്തൃസമിതികൾക്ക് ആവശ്യമായ ബോധവൽക്കരണ പരിശീലന പരിപാടികൾ നിർവ്വഹണഘട്ടത്തിലും നിർവ്വഹണാനന്തര ഘട്ടത്തിലും സംഘടിപ്പിക്കുക.
15. ഗുണഭോക്തൃസമിതി പ്രതിനിധികളെ വിളിച്ച് ചേർത്ത് പദ്ധതി പ്രവർത്തനം അവലോകനം ചെയ്യുകയും പ്രശ്നങ്ങൾക്ക് പരിഹാരം കാണുകയും ചെയ്യുക.
16. KRWSA നടത്തുന്ന പരിശീലന പരിപാടികളിൽ പങ്കെടുക്കുക.
17. സാമൂഹ്യ ഉടമസ്ഥതയിലുള്ള കടിവെള്ള വിതരണ പദ്ധതികളുടെ തുടർനടത്തിപ്പും



I/20214/2022

പരിപാലനവും സംബന്ധിച്ച് KRWSA നൽകിയിട്ടുള്ള മാർഗ്ഗരേഖ അംഗീകരിച്ചുകൊണ്ട് ഗുണഭോക്തൃ സമിതികൾ തുടർ നടത്തിപ്പും പരിപാലനവും നടത്തുന്നുണ്ടെന്ന് ഉറപ്പു വരുത്തുക.

- 18. വിവിധ പദ്ധതികൾക്കായി ഗ്രാമപഞ്ചായത്ത് തലത്തിൽ ഗ്രാമപഞ്ചായത്ത് വിഹിതം നിക്ഷേപിക്കുന്നതിനും, ഗുണഭോക്തൃ വിഹിതം സ്വരൂപിക്കുന്നതിനും വേണ്ടി ഗ്രാമ പഞ്ചായത്ത് പ്രസിഡന്റ്, സെക്രട്ടറി എന്നിവരുടെ പേരിൽ നാഷണലൈസ്ഡ് / ഷെഡ്യൂൾഡ് ബാങ്കിൽ പ്രത്യേകം ജോയിന്റ് സേവിങ്ങ്സ് ബാങ്ക് അക്കൗണ്ട് ആരംഭിക്കുക.
- 19. ഗ്രാമപഞ്ചായത്ത് പ്രസിഡന്റ്, സെക്രട്ടറി എന്നിവരുടെ പേരിലുള്ള സംയുക്ത ബാങ്ക് അക്കൗണ്ടിൽ നിക്ഷേപിക്കുന്ന ഗ്രാമപഞ്ചായത്ത് വിഹിതം , ഗുണഭോക്തൃവിഹിതം, അതിന്റെ പലിശ തുക എന്നിവ അതാത് ഗ്രാമപഞ്ചായത്തുകളിൽ മേൽ സൂചിപ്പിച്ച പദ്ധതികളുടെയും മറ്റ് സാമൂഹ്യ ഉടമസ്ഥതയിലുള്ള കുടിവെള്ള വിതരണ പദ്ധതികളുടെയും തുടർനടത്തിപ്പിനും പരിപാലനത്തിനുമുള്ള റിവോൾവിംഗ് ഫണ്ടായി വിനിയോഗിക്കുക.
- 20. പദ്ധതികളുടെ തുടർ നടത്തിപ്പും പരിപാലനവുമായി ബന്ധപ്പെട്ട് തദ്ദേശ സ്വയംഭരണ സ്ഥാപനം ആവശ്യപ്പെടുന്നതനുസരിച്ചുള്ള സാങ്കേതിക- മാനേജ്മെന്റ് സഹായങ്ങൾ ലഭ്യമാക്കുന്നതിന് വേണ്ടി backstopping support agency എന്ന നിലയിൽ KRWSA ക്ക് മേൽ പറഞ്ഞ ബാങ്ക് അക്കൗണ്ടിൽ നിന്നും ആവശ്യമായ തുക നൽകുക.

**ഗ്രാമ പഞ്ചായത്ത് ലെവൽ ആക്ടിവിറ്റി കമ്മിറ്റി (GPLAC)**

നിർവ്വഹണത്തിനായി ഏറ്റെടുത്തിട്ടുള്ള പദ്ധതികളുടെ ഗുണഭോക്തൃ സമിതിയുടെയും സ്ഥാപനങ്ങളുടെയും പ്രതിനിധികൾ ഉൾപ്പെട്ട പദ്ധതി നിർവ്വഹണ സംവിധാനമാണ് ഗ്രാമപഞ്ചായത്ത് തല ആക്ടിവിറ്റി കമ്മിറ്റി (GPLAC). ഇത് പദ്ധതി നിർവ്വഹണത്തിന് വേണ്ടി മാത്രമുള്ള സംവിധാനമാണ്. ഗ്രാമപഞ്ചായത്തിലെ ഒരു ഗുണഭോക്തൃസമിതി / SLEC യിൽ മാത്രമാണ് പ്രവൃത്തികൾ നടത്തുവാനുള്ളതെങ്കിൽ പ്രത്യേകം GPLAC രൂപീകരിക്കേണ്ടതില്ല. GPLAC യ്ക്ക് പകരം പ്രസ്തുത സമിതിയാണ് പ്രവൃത്തികൾ നടപ്പിലാക്കുന്നത്. വ്യക്തിഗത ഗുണഭോക്താക്കൾക്കുള്ള പദ്ധതി മാത്രമുള്ള ഗ്രാമപഞ്ചായത്തുകളിൽ ഗുണഭോക്താക്കളുടെ ഒരു സമിതി രൂപീകരിച്ച് പ്രവൃത്തികൾ നടത്താവുന്നതാണ്.

പഞ്ചായത്തിൽ ഒന്നിൽ കൂടുതൽ ഗുണഭോക്തൃ സമിതികളിൽ / സ്കീം ലെവൽ കമ്മിറ്റിയിൽ പ്രവൃത്തികൾ നടത്തേണ്ടതുണ്ടെങ്കിൽ ആ സമിതികൾ പദ്ധതി നടത്തിപ്പിനായുള്ള GPLAC യിൽ അംഗമാകണം. മുൻ വർഷങ്ങളിലെ പദ്ധതികളുമായി ബന്ധപ്പെട്ടു നിലവിൽ GPLAC പ്രവർത്തിക്കുന്ന ഗ്രാമപഞ്ചായത്തുകളിൽ, പ്രവൃത്തികൾ നടപ്പിലാക്കുന്ന പുതിയ സമിതിയുടെ 2 പ്രതിനിധികളെയും, സ്ഥാപനങ്ങൾ ഉണ്ടെങ്കിൽ അവരുടെ 2 പ്രതിനിധികളെയും കൂടി GPLAC യിൽ ഉൾപ്പെടുത്തേണ്ടതാണ്. വ്യക്തിഗത ഗുണഭോക്താക്കൾക്കുള്ള പദ്ധതി ഉണ്ടെങ്കിൽ അവരുടെ ഒരു പ്രതിനിധിയെ കൂടി ഉൾപ്പെടുത്തണം. പൊതു ഇടങ്ങളിലെ പദ്ധതിയാണെങ്കിൽ അവിടെ ഒരു സമിതി രൂപീകരിക്കുകയും ഒരു പ്രതിനിധിയെ GPLAC യിൽ ഉൾപ്പെടുത്തുകയും വേണം. നിലവിൽ GPLAC ഇല്ലാത്ത ഗ്രാമപഞ്ചായത്തുകളിൽ മേൽ പറഞ്ഞ രീതിയിൽ അംഗങ്ങളെ ഉൾപ്പെടുത്തി പുതിയ GPLAC രൂപീകരിക്കേണ്ടതാണ്. ഈ പ്രതിനിധികൾ ചേർന്ന് GPLAC ക്ക് പ്രസിഡന്റ്, സെക്രട്ടറി, ഖജാൻജി ആവശ്യമായ മറ്റു ഭാരവാഹികൾ, എക്സിക്യൂട്ടീവ് അംഗങ്ങൾ എന്നിവരെ തിരഞ്ഞെടുക്കണം. GPLAC രൂപീകരിക്കുന്ന നടപടികൾക്ക് GP നേതൃത്വം നൽകണം.

ക്രമ നം.	പദ്ധതി പേരുകൾ
----------	---------------

I/20214/2022

1	സുസ്ഥിരത പദ്ധതി (കുടിവെള്ള വിതരണ പദ്ധതികളുടെ പുനരുദ്ധാരണ- നവീകരണ പ്രവൃത്തികൾ)
2	ജലഗുണനിലവാരം മെച്ചപ്പെടുത്തൽ, ഗ്രേ വാട്ടർ മാനേജ്മെന്റ്.
3	ഗാർഹിക കിണറുകളെ സംരക്ഷിതവും സുസ്ഥിരവുമായ കുടിവെള്ള സ്രോതസ്സുകളാക്കി മാറ്റുന്ന പ്രവൃത്തികൾ.
4	മഴവെള്ള സംഭരണം, ഭൂജല റീചാർജ്ജ് പ്രവൃത്തികൾ (RWH &GWR)

**ഗുണഭോക്തൃസമിതി(BG) / സ്ത്രീം ലെവൽ എക്സിക്യൂട്ടീവ് കമ്മിറ്റി (SLEC)/ ഗ്രാമ പഞ്ചായത്ത് ലെവൽ ആക്ടിവിറ്റി കമ്മിറ്റിയുടെ(GPLAC) ഉത്തരവാദിത്വം ചുമതലകളും**

1. പദ്ധതി നടത്തിപ്പുമായി ബന്ധപ്പെട്ട് KRWSA നൽകുന്ന നിർദ്ദേശങ്ങൾ പാലിക്കുക. നിർദ്ദേശ പ്രകാരമുള്ള കരാറുകൾ ഒപ്പിടുക.
2. പദ്ധതിയിൽ ഉൾപ്പെടുന്ന ഗുണഭോക്തൃസമിതികൾ/സ്ഥാപനങ്ങൾ നിർവഹണ മാർഗ്ഗരേഖ അംഗീകരിക്കുക
3. വിവിധ പദ്ധതി പ്രവർത്തനങ്ങൾക്കായുള്ള പദ്ധതി തുകയുടെ KRWSA നിർദ്ദേശിക്കുന്ന നിശ്ചിത ശതമാനം ഗുണഭോക്തൃ വിഹിതം ബന്ധപ്പെട്ട സമിതി എടുക്കേണ്ടതാണ്. ഈ വിഹിതം പണമായാണ് എടുക്കേണ്ടത്. ആയത് ഗ്രാമപഞ്ചായത്തിന്റെ ഈ ആവശ്യവുമായി ബന്ധപ്പെട്ടുള്ള ജോയിന്റ് ബാങ്ക് അക്കൗണ്ടിൽ നിക്ഷേപിക്കണം. (സുസ്ഥിരതാ പദ്ധതിയിൽ SC/ST/ഫിഷർമെൻ കമ്മ്യൂണിറ്റി എന്നിവർക്ക് ഗുണഭോക്തൃ വിഹിതം 5% ആയിരിക്കും. മഴവെള്ള സംഭരണി നിർമ്മാണ പദ്ധതിയിൽ മേൽ സൂചിപ്പിച്ച വിഭാഗങ്ങൾക്ക് പുറമേ BPL വിഭാഗത്തിനും ഗുണഭോക്തൃ വിഹിതം എടുക്കേണ്ടതില്ല. എന്നാൽ ഗുണഭോക്തൃക്കൾ ഏതു വിഭാഗത്തിൽ ഉൾപ്പെട്ടവരാണ് എന്നത് സംബന്ധിച്ച് ഗ്രാമപഞ്ചായത്ത് പ്രസിഡന്റ് അല്ലെങ്കിൽ സെക്രട്ടറി നൽകുന്ന സാക്ഷ്യപത്രം ഗുണഭോക്തൃക്കൾ ഹാജരാക്കണം)
4. പദ്ധതിസ്മാരക ബന്ധപ്പെട്ട് KRWSA, ഗ്രാമപഞ്ചായത്ത്, ബിസി ഫെഡറേഷൻ, മറ്റ് സർക്കാർ ഏജൻസികൾ നടത്തുന്ന അവലോകനയോഗങ്ങൾ, പരിശീലനപരിപാടികൾ എന്നിവയിൽ പങ്കെടുക്കുക. പദ്ധതിയുടെ തത്വം, ഘടകങ്ങൾ, നിർവ്വഹണരീതി, പങ്കാളികളുടെ ചുമതലകൾ, ചെലവ് പങ്കിടൽ രീതി, സമയപാലനം, തുടർനടത്തിപ്പ് പരിപാലനവും തുടങ്ങി പദ്ധതിയുടെ അടിസ്ഥാന വിവരങ്ങൾ സംബന്ധിച്ച് ഗുണഭോക്തൃസമിതി ആവശ്യമായ അറിവു നേടുക.
5. വിവിധ ഏജൻസികൾ പദ്ധതിയുമായി ബന്ധപ്പെട്ട് നടത്തുന്ന ഓഡിറ്റിംഗ് , പരിശോധനകൾ, വിലയിരുത്തൽ എന്നിവയുമായി സഹകരിക്കുക.പദ്ധതിയുമായി ബന്ധപ്പെട്ടുള്ള തർക്കങ്ങൾ പരിഹരിക്കുന്നതിനും തുടർ നടത്തിപ്പ് വിജയകരമാക്കുന്നതിനും ഗ്രാമപഞ്ചായത്ത് നൽകുന്ന അഭിപ്രായങ്ങൾ, നിർദ്ദേശങ്ങൾ എന്നിവ ഉൾക്കൊണ്ടു പ്രവർത്തിക്കുക.
6. സുസ്ഥിരതാ പദ്ധതിയിൽ ഏറ്റെടുത്തു പുനരുദ്ധരിക്കുന്ന എല്ലാ കുടിവെള്ള പദ്ധതിയുടെയും ആസ്തികൾ അതാത് ഗുണഭോക്തൃസമിതിയുടേയും ഗ്രാമപഞ്ചായത്തിന്റെയും സംയുക്ത ഉടമസ്ഥതയിലാക്കുക.
7. സാമൂഹ്യ ഉടമസ്ഥതയിലുള്ള കുടിവെള്ള വിതരണ പദ്ധതികളുടെ തുടർനടത്തിപ്പ് പരിപാലനവുമായി ബന്ധപ്പെട്ട് കെ.ആർ.ഡബ്ല്യു.എസ്.എ നല്ലിയിട്ടുള്ള മാർഗ്ഗരേഖയുടെ അടിസ്ഥാനത്തിൽ തുടർനടത്തിപ്പ് നിയമാവലി തയ്യാറാക്കി അംഗീകരിച്ച് ആയതനുസരിച്ച് ഗുണഭോക്തൃ സമിതികൾ പ്രവർത്തിക്കുക.
8. സുസ്ഥിരത പദ്ധതിയിൽ ഏറ്റെടുത്തിട്ടുള്ള ഗുണഭോക്തൃസമിതികൾ ഫണ്ട് ഉപയോഗം, കണക്കുബുക്കുകൾ, റിക്കാർഡുകൾ എന്നിവ സൂക്ഷിക്കുന്നതോടൊപ്പം

I/20214/2022

കെ.ആർ.ഡബ്ല്യു.എസ്.എ കാലാകാലങ്ങളിൽ നിർദ്ദേശിക്കുന്ന മറ്റ് രേഖകളും സൂക്ഷിക്കേണ്ടതാണ്. ഇക്കാര്യങ്ങളിൽ ഗുണഭോക്തൃസമിതി അറിവ് നേടേണ്ടതാണ്. പദ്ധതിയുടെ തുടർനടത്തിപ്പ് പരിപാലനം എന്നിവയുടെ പ്രാധാന്യം മനസ്സിലാക്കി ആവശ്യമായ കഴിവ് ഗുണഭോക്തൃസമിതി ആർജ്ജിക്കണം.

9. ഗുണഭോക്തൃസമിതികൾ അവരുടെ പഞ്ചായത്തുതല കൂട്ടായ്മയായ ബിജി ഫെഡറേഷനിൽ അംഗമാകണം. അതോടൊപ്പം ഗ്രാമപഞ്ചായത്ത് തലത്തിൽ രൂപീകരിക്കുന്ന മോണിറ്ററിംഗ് കമ്മിറ്റിയുടെ തുടർനടത്തിപ്പും പരിപാലനവുമായി ബന്ധപ്പെട്ട നിർദ്ദേശങ്ങൾ അംഗീകരിക്കണം.
10. പദ്ധതി നിർവഹണത്തിന് ആവശ്യമായ സാധനങ്ങൾ/സേവനങ്ങൾ എന്നിവയ്ക്ക് കോട്ടേഷൻ വിളിക്കുന്നതും, അംഗീകരിക്കുന്നതും വർക്ക് ഓർഡർ നൽകുന്നതും GPLAC ഉള്ള ഗ്രാമപഞ്ചായത്തുകളിൽ GPLAC യും അല്ലാത്തതിടങ്ങളിൽ ബന്ധപ്പെട്ട BG അല്ലെങ്കിൽ SLEC ആയിരിക്കും ചെയ്യുന്നത്. മുപ്പത് ലക്ഷം രൂപയ്ക്ക് മുകളിൽ അടങ്കൽ വരുന്ന പ്രവൃത്തികളുടെയും, ഇ-ടെണ്ടർ മുഖേന ഉള്ള എല്ലാ പ്രവൃത്തികളുടെയും ടെണ്ടർ നടപടികളുടെ പൂർത്തീകരണം ഇ-ടെണ്ടർ നടപടിക്രമങ്ങൾ പാലിച്ചു കൊണ്ട് സമിതി / GPLAC ക്ക് വേണ്ടി KRWSA യുടെ മേഖല ഓഫീസുകളാണ് നടത്തേണ്ടത്. Krwsa യുടെ റീജിയണൽ ഡയറക്ടർ,മാനേജർ ടെക്നിക്കൽ,അക്കൗണ്ട്സ് ഓഫീസർ എന്നിവരായിരിക്കും നിലവിൽ ടെണ്ടർ ഇവാലുവേഷൻ കമ്മിറ്റിയിലെ അംഗങ്ങൾ.
11. വ്യക്തിഗത ഗുണഭോക്താക്കൾക്കുള്ള പദ്ധതികളുടെ പൂർത്തീകരണത്തിനുശേഷം അതാത് ഗുണഭോക്താക്കളിൽ നിന്നും പൂർത്തീകരണ സാക്ഷ്യപത്രം കെ.ആർ.ഡബ്ല്യു.എസ്.എ നിർദ്ദേശിക്കുന്ന ഫോർമാറ്റിൽ ലഭ്യമാക്കേണ്ടതാണ്.
12. പദ്ധതി പൂർത്തീകരണത്തിനുശേഷം സോഷ്യൽ ഓഡിറ്റ് റിപ്പോർട്ട് സമർപ്പിക്കുക.

**സാങ്കേതികാനുമതി**

KRWSA യിൽ നിലവിലുള്ള 29.3.22 തീയതിയിലെ KRWSA-PMU/3316/2017-TA(Tech) നമ്പർ സർക്കുലർ പ്രകാരം സാങ്കേതിക അനുമതി നൽകണം.

**പദ്ധതി നിർവ്വണം - സാധനങ്ങളും സേവനങ്ങളും ലഭ്യമാക്കുന്ന രീതി**

ക്രമ നം	അടങ്കൽ	നിർവ്വഹണ രീതി	കമ്പാരറ്റീവ് സ്റ്റേറ്റ്‌മെന്റ് തയ്യാറാക്കൽ	കമ്പാരറ്റീവ് സ്റ്റേറ്റ്‌മെന്റ് അംഗീകരിക്കൽ
1	30 ലക്ഷം വരെ	കമ്മ്യൂണിറ്റി കോൺട്രാക്റ്റിംഗ് (കാട്ടേഷൻ)മുഖേനയോ ആവശ്യമെങ്കിൽ ഇ-ടെണ്ടർ മുഖേനയോ	PC	സാങ്കേതികാനുമതി നൽകിയ ഉദ്യോഗസ്ഥൻ
2	30 ലക്ഷത്തിന് മുകളിൽ	ഇ-ടെണ്ടർ	PC	സാങ്കേതികാനുമതി നൽകിയ ഉദ്യോഗസ്ഥൻ

മുപ്പത് ലക്ഷം രൂപയ്ക്ക് താഴെ അടങ്കൽ തുക വരുന്ന എല്ലാ പ്രവൃത്തികൾക്കും സാങ്കേതികാനുമതി നൽകിയ ഉദ്യോഗസ്ഥന്റെ അനുമതിയോടു കൂടി സംയോജിത കരാർ മുഖേനയോ വെവ്വേറെ കരാർ മുഖേനയോ കമ്മ്യൂണിറ്റി കോൺട്രാക്റ്റിംഗ് രീതിയിലും അല്ലെങ്കിൽ ഇ-ടെണ്ടർ മുഖേനയും നിർവ്വഹണം നടത്താവുന്നതാണ്. പ്രവൃത്തികളുടെ കാട്ടേഷൻ/ടെണ്ടർ തുറക്കുന്നതിന്റെ

I/20214/2022

ഉത്തരവാദിത്വം പ്രൊജക്ട് കമ്മീഷണർ / സീനിയർ എഞ്ചിനീയർ / മാനേജർ ടെക്നിക്കൽ എന്നിവരിൽ നിക്ഷിപ്തമാണ്. കമ്മ്യൂണിറ്റി കോൺടാക്റ്റ് മുഖേന നടപ്പിലാക്കുന്ന പ്രവൃത്തികൾക്ക് PAC തുകയുടെ 10% വരെയുള്ള excess തുക മാനേജർ ടെക്നിക്കലിന്റെ റിപ്പോർട്ടിന്റെ അടിസ്ഥാനത്തിൽ റീജിയണൽ ഡയറക്ടർക്ക് അനുവദിക്കാവുന്നതാണ്. പമ്പ് സെറ്റും അനുബന്ധ സാധനങ്ങളും വാങ്ങുമ്പോൾ അംഗീകൃത ഡീലർമാരിൽ നിന്നും ISI മാർക്കുള്ളവ വാങ്ങണം. ക്വട്ടേഷൻ/ടെണ്ടറുകൾ അംഗീകരിക്കുമ്പോൾ KRWSA സുസ്ഥിരതാ പദ്ധതിയുമായി ബന്ധപ്പെട്ട് ഈ മാർഗ്ഗരേഖയിൽ ഇല്ലാത്തതും മുൻപ് നൽകിയിട്ടുള്ള മാർഗ്ഗരേഖയിൽ പരാമർശിട്ടില്ലാത്തതുമായ കാര്യങ്ങളിൽ നിലവിലുള്ള സർക്കാർ ഉത്തരവുകൾ പാലിക്കേണ്ടതാണ്.

**ഇ-ടെണ്ടർ മുഖേന നടപ്പിലാക്കുന്ന പ്രവൃത്തികളുടെ ടെണ്ടർ ഫോം ഫീസ്**

നിലവിലുള്ള സർക്കാർ ഉത്തരവ് നമ്പർ G.O.(P) 429/15/Fin Dated 28/09/2015 പ്രകാരം ടെണ്ടർ ഫോം ഫീസ്, EMD തുക എന്നിവ ചുവടെ ചേർത്തിരിക്കുന്നു.

ക്രമ നം	വിശദാംശങ്ങൾ	ടെണ്ടർ ഫോം ഫീസ്(രൂപ)*	EMD തുക
1	TPAC up to 50,000	300	2.5% Maximum 50,000
2	TPAC 50,000 – 10 lakh	0.2% (Min 500 – Max 2000)	
3	TPAC 10 lakh – 1 Cr	2,500	
4	TPAC 1 Cr – 2 Cr	5,000	
5	TPAC 2 Cr – 5 Cr	7,500	1 Lakh
6	TPAC 5 Cr – 10 Cr	10,000	2 Lakh
7	TPAC >10 Cr	15,000	5 Lakh

\* കാലകാലങ്ങളിലായി സർക്കാർ പുറപ്പെടുവിക്കുന്ന ഉത്തരവുകൾ അനുസരിച്ച് ഇതിൽ മാറ്റം വരുന്നതാണ്.

**പദ്ധതിയുമായി ബന്ധപ്പെട്ട കരാറുകൾ**

ക്രമ നം	പദ്ധതി	കരാർ	കക്ഷികൾ	മുദ്ര പത്രത്തിന്റെ മൂല്യം
1	ആസൂത്രണ കരാർ	ത്രികക്ഷി കരാർ	KRWSA മേഖല പ്രൊജക്ട് ഡയറക്ടർ, ഗ്രാമപഞ്ചായത്ത് പ്രസിഡണ്ട്, GPLAC പ്രസിഡന്റ്	Rs.200 (മുദ്രപത്രം KRWSA വാങ്ങണം)
2	നിർവ്വഹണ കരാർ	ത്രികക്ഷി കരാർ	KRWSA മേഖല പ്രൊജക്ട് ഡയറക്ടർ, GPLAC പ്രസിഡന്റ്, കരാറുകാരൻ.	സർക്കാർ ഉത്തരവ് പ്രകാരമുള്ള നിരക്കിലുള്ള മുദ്രപത്രം കരാറുകാരൻ വാങ്ങണം.

**കടിവെള്ള വിതരണ സ്തൂമുകളുടെ പുനരുദ്ധാരണ - നവീകരണ പ്രവൃത്തികൾക്ക് സർക്കാർ ഫണ്ട് ലഭ്യമാക്കുന്നതിനുള്ള വ്യവസ്ഥകൾ**

സുസ്ഥിരത പദ്ധതിയിൽ സർക്കാർ ഫണ്ട് ലഭ്യമാകണമെങ്കിൽ ഗുണഭോക്തൃ സമിതികൾ താഴെ പറയുന്ന തീരുമാനങ്ങൾ പൊതുയോഗത്തിൽ കൈകൊണ്ട് മിനിട്ട്സിന്റെ പകർപ്പ്

I/20214/2022

ഗ്രാമപഞ്ചായത്തുകൾക്ക് നൽകേണ്ടതാണ്.

1. സമിതിയുടെ കടിവെള്ള വിതരണ സ്കീമിന്റെ ആസ്തികളിന്മേൽ സംയുക്ത ഉടമസ്ഥാവകാശം ഗ്രാമപഞ്ചായത്തിന് നൽകിക്കൊണ്ടുള്ള പൊതുയോഗ തീരുമാനം.
2. പദ്ധതി ഗുണഭോക്താക്കളുടെ വീടുകളിൽ വാട്ടർ മീറ്ററുകൾ സ്ഥാപിച്ച് വെള്ളത്തിന്റെ ഉപയോഗത്തിനനുസരിച്ച് വെള്ളക്കരം വാങ്ങിക്കൊള്ളാം എന്നുള്ള പൊതുയോഗ തീരുമാനം.
3. കടിവെള്ള പദ്ധതിയുടെ തുടർനടത്തിപ്പിനും പരിപാലനത്തിനും വേണ്ടിയുള്ള തുടർനടത്തിപ്പ് നിയമാവലി അംഗീകരിച്ച് അതനുസരിച്ച് പ്രവർത്തിച്ചുകൊള്ളാം എന്നുള്ള പൊതുയോഗ തീരുമാനം.
4. സാമ്പത്തിക ഇടപാടുകളിലെ സുതാര്യത ഉറപ്പുവരുത്തുന്നതിനുവേണ്ടി, സാമ്പത്തിക ഇടപാടുകൾ ബാങ്ക് വഴിയാക്കുന്നതിനും കണക്കുകൾ എഴുതി സൂക്ഷിക്കുന്നതിനും, സംഘടനാ സംവിധാനം മെച്ചപ്പെടുത്തുന്നതിന് എല്ലാ വർഷവും പൊതുയോഗം ചേർന്ന് പുതിയ ഭാരവാഹികളെ തിരഞ്ഞെടുത്തു കൊള്ളാമെന്നുള്ള പൊതുയോഗ തീരുമാനം.
5. പദ്ധതി ചെലവിന്റെ 10 ശതമാനം (10% പൊതു വിഭാഗത്തിനും 5% SC/ST/Fishermen വിഭാഗത്തിനും) ഗുണഭോക്തൃ വിഹിതമായി എടുത്തുകൊള്ളാം എന്നുള്ള പൊതുയോഗ തീരുമാനം.

**മഴവെള്ള സംഭരണം / കിണർ റീചാർജ്ജ് / സ്ത്രോതസ്സുകളുടെ സുസ്ഥിരത ഉറപ്പാക്കൽ - പദ്ധതി ഗുണഭോക്താക്കളെ തിരഞ്ഞെടുക്കുന്നതിനുള്ള മാനദണ്ഡം.**

1. നിശ്ചിത മാതൃകയിലുള്ള അപേക്ഷാ ഫോറം വിതരണം ചെയ്ത് അപേക്ഷകരെ ഗ്രാമപഞ്ചായത്ത് തിരഞ്ഞെടുക്കേണ്ടതാണ്. അപേക്ഷ ക്ഷണിക്കുന്ന വിവരം ഗ്രാമപഞ്ചായത്ത് നോട്ടീസ് ബോർഡിലും ഭരണ സമിതി യോഗത്തിലും പരസ്യപ്പെടുത്തേണ്ടതാണ്. അപേക്ഷയോടൊപ്പം റേഷൻകാർഡിന്റെയും ആധാർ കാർഡിന്റെയും പകർപ്പ് സമർപ്പിക്കേണ്ടതാണ്.
2. നിലവിൽ സ്വന്തമായി ഗാർഹിക ജലസ്ത്രോതസ്സ് ഇല്ലാത്തവരും, ജലസ്ത്രോതസ്സ് ഉണ്ടെങ്കിൽ പോലും വേനൽക്കാലത്ത് കടുത്ത കടിവെള്ള ക്ഷാമം അനുഭവിക്കുന്നവരുമായ SC/ST/Fishermen community/BPL വിഭാഗത്തിൽ ഉൾപ്പെട്ടവർക്ക് മുൻഗണന നൽകി വേണം മഴവെള്ള സംഭരണ നിർമ്മാണ പദ്ധതിയിലെ ഗുണഭോക്താക്കളെ തിരഞ്ഞെടുക്കേണ്ടത്. ഈ വിഭാഗത്തിൽ ഉൾപ്പെട്ടവർ ഇല്ല എങ്കിൽ APL വിഭാഗത്തിൽപ്പെട്ടവരെ പരിഗണിക്കാവുന്നതാണ്. APL വിഭാഗത്തിൽ ഉൾപ്പെട്ടവർ 10% ഗുണഭോക്തൃ വിഹിതം അടക്കണം. ഗ്രാമപഞ്ചായത്തിലെ സർക്കാർ സ്ഥാപനങ്ങൾ, പൊതു സ്ഥാപനങ്ങൾ, വിദ്യാലയങ്ങൾ, സർക്കാർ ആശുപത്രികൾ തുടങ്ങിയുള്ള സ്ഥാപനങ്ങൾക്കും മുൻഗണന നൽകണം.
3. ഗാർഹിക കിണറുകളെ സംരക്ഷിതവും സുസ്ഥിരവുമായ കടിവെള്ള സ്ത്രോതസ്സുകളാക്കി മാറ്റുന്ന പ്രവൃത്തികൾക്ക് തിരഞ്ഞെടുക്കപ്പെടുന്ന അപേക്ഷകർക്ക് സ്വന്തമായി വീടും കിണറും ഉണ്ടായിരിക്കണം. SC/ST/Fishermen community/BPL വിഭാഗത്തിൽ ഉൾപ്പെടുന്നവർക്ക് മുൻഗണന നൽകണം.
4. മഴവെള്ള സംഭരണ നിർമ്മാണം, ഗാർഹിക കിണറുകളെ സംരക്ഷിതവും സുസ്ഥിരവുമായ കടിവെള്ള സ്ത്രോതസ്സുകളാക്കി മാറ്റുന്ന പ്രവൃത്തികൾ എന്നിവയിലേക്കുള്ള മുൻഗണനലിസ്റ്റിൽ പെട്ടവരുടെ ഭവനസന്ദർശനവും, പ്രവൃത്തികൾ

I/20214/2022

നടപ്പിലാക്കുവാൻ ഉദ്ദേശിക്കുന്ന സ്ഥലവും സന്ദർശിച്ച് technically feasible ആയ അപേക്ഷകരുടെ ലിസ്റ്റ് KRWSA ഗ്രാമപഞ്ചായത്തിന് നൽകുകയും ആയത് ഗ്രാമ പഞ്ചായത്ത് പരിശോധിച്ച് അംഗീകരിച്ചു നൽകുകയും വേണം. ടി അന്തിമ ലിസ്റ്റിൽ ഉൾപ്പെടുത്തുവാനായിരിക്കും പദ്ധതിയുടെ ഗുണഭോക്താക്കൾ.

5. ഗുണഭോക്താക്കളുടെ മുൻഗണനാ ലിസ്റ്റും അവരുടെ അപേക്ഷ ഫോറങ്ങളും ഗ്രാമപഞ്ചായത്ത് KRWSA ക്ക് നൽകണം. അന്തിമ ലിസ്റ്റ് നൽകുമ്പോൾ ഗ്രാമപഞ്ചായത്ത് തീരുമാനവും അതോടൊപ്പം ഉൾപ്പെടുത്തണം.

**സർക്കാർ സ്ഥാപനങ്ങളിലും, പൊതു ഇടങ്ങളിലും മഴവെള്ള സംഭരണം, ഭൂജലപരിപോഷണ പ്രവർത്തനം, മലിനജല നിർമ്മാർജ്ജനം എന്നീ പ്രവൃത്തികൾ നടത്തുന്നതിനുള്ള നടപടിക്രമങ്ങൾ.**

1. പദ്ധതി സംബന്ധിച്ച് KRWSA യിൽ നിന്നും ബന്ധപ്പെട്ട ഗ്രാമപഞ്ചായത്തിനും സർക്കാർ സ്ഥാപനത്തിനും രേഖാമൂലം അറിയിപ്പ് നൽകേണ്ടതാണ്. ഭരണാനുമതിയുടെയും, എസ്റ്റിമേറ്റിന്റെയും, സാങ്കേതിക അനുമതിയുടെയും പകർപ്പുകളും നൽകേണ്ടതാണ്.
2. സൈറ്റിൽ നിർമ്മാണ പ്രവൃത്തി നടത്തുന്നതിനു വേണ്ടി സ്ഥാപന മേധാവി രേഖാമൂലം അനുമതി പത്രം നൽകണം.
3. പദ്ധതി നിർവ്വഹണത്തിന് വേണ്ടി ഗ്രാമപഞ്ചായത്ത് തലത്തിൽ രൂപം കൊടുക്കുന്ന GPLAC യിൽ ബന്ധപ്പെട്ട സ്ഥാപനങ്ങളുടെ/ഗുണഭോക്തൃ സമിതിയുടെ പ്രതിനിധികളെ ഉൾപ്പെടുത്തേണ്ടതാണ്.
4. പദ്ധതിയുടെ ഭാഗമായി സ്ഥാപനങ്ങളിലും പൊതു ഇടങ്ങളിലും നടപ്പിലാക്കുന്ന പ്രവൃത്തികളുടെ ഗുണഭോക്താവ്/ഗുണഭോക്തൃ സംവിധാനം /സ്ഥാപനം ടി പദ്ധതിയുടെ തുടർ നടത്തിപ്പ്, പരിപാലനം എന്നിവയ്ക്ക് വേണ്ടി വ്യക്തമായ ഒരു പ്ലാൻ KRWSA യുടെ സഹായത്തോടെ തെയ്യാറാക്കുകയും അതുപ്രകാരം പ്രവർത്തിക്കുകയും വേണം.
5. പ്രവൃത്തി പൂർത്തീകരണത്തിന് ശേഷം പൂർത്തീകരണ സാക്ഷ്യപത്രം ബന്ധപ്പെട്ട സ്ഥാപന മേധാവി നൽകണം.

**പദ്ധതി നിർവ്വഹണ സാങ്കേതിക മേൽനോട്ടം**

പദ്ധതി നിർവ്വഹണത്തിൻറെ സാങ്കേതിക മേൽനോട്ടം KRWSA യുടെ സാങ്കേതിക വിഭാഗം നടത്തേണ്ടതും ഗുണനിലവാരം ഉറപ്പു വരുത്തി സമയബന്ധിതമായി പദ്ധതി പൂർത്തീകരിക്കേണ്ടതുമാണ്. കമ്മ്യൂണിറ്റി കോൺട്രാക്റ്റിൽ സാധന സാമഗ്രികൾ ആവശ്യത്തിന് മാത്രം വാങ്ങിക്കേണ്ടതാണ്. സാധന സാമഗ്രികൾ / സേവനങ്ങൾ എന്നിവയുടെ യഥാക്രമം അളവുകൾ / തോത് എന്നിവ സംബന്ധിച്ച ഉത്തരവാദിത്വം പ്രോജക്ട് കമ്മീഷണർമാർക്കായിരിക്കും. പദ്ധതി നിർവ്വഹണത്തിന് ഉപയോഗിക്കുന്നതും പൊതുവിപണിയിൽ ലഭ്യമായതുമായ സാധനങ്ങൾക്ക് ഐഎസ്ഐ മാർക്ക് നിർബന്ധമാണ്. പ്രാദേശികമായി ഉണ്ടാകുന്ന തർക്കങ്ങൾ ഗ്രാമപഞ്ചായത്ത് ഇടപെട്ട് പരിഹരിക്കണം.

**പദ്ധതിയുടെ അളവുകൾ ബില്ലുകൾ തയ്യാറാക്കൽ**

പദ്ധതി നിർവ്വഹണത്തിൻറെ ഭാഗമായുള്ള ആസ്തികളുടെ / പ്രവൃത്തികളുടെ അളവുകൾ രേഖപ്പെടുത്തേണ്ടതും ബില്ലുകൾ തയ്യാറാക്കേണ്ടതും KRWSA യുടെ സാങ്കേതിക വിഭാഗം ആയിരിക്കണം. ബില്ലുകൾക്ക് അംഗീകാരം നൽകേണ്ടത് താഴെ പറയും പ്രകാരമാണ്.

അളവുകൾ രേഖപ്പെടുത്തേണ്ട ഉദ്യോഗസ്ഥൻ	അളവുകൾ ചെക്ക് മെഷർ ചെയ്യേണ്ട ഉദ്യോഗസ്ഥൻ	അളവുകൾ അംഗീകരിക്കേണ്ട ഉദ്യോഗസ്ഥൻ
പ്രോജക്ട് കമ്മീഷണർ	സീനിയർ എഞ്ചിനീയർ	മാനേജർ ടെക്നിക്കൽ/ ഡയറക്ടർ ടെക്നിക്കൽ

I/20214/2022

**പണം അനുവദിക്കൽ**

പദ്ധതി നിർവ്വഹണത്തിന്റെ പുരോഗതിക്കനുസരിച്ച് പരമാവധി മൂന്ന് ബില്ലുകളായി കരാറുകാരന്റെ അക്കൗണ്ടിലേക്ക് KRWSA യിൽ നിന്നും നേരിട്ടാണ് പണം നൽകുന്നത്. ഫണ്ട് അനുവദിച്ചു കൊണ്ടുള്ള ഉത്തരവിന്റെ പകർപ്പ് ബന്ധപ്പെട്ട പദ്ധതി പങ്കാളികൾക്ക് നൽകുന്നതാണ്. പ്രവൃത്തികൾ ഏറ്റെടുത്ത കരാറുകാരനിൽ നിന്നും വിവിധ ഇനങ്ങളിൽ ഉള്ള ടാക്സുകൾ /നികുതികൾ സർക്കാർ നിശ്ചയിച്ചിട്ടുള്ള നിരക്കിൽ ഈടാക്കി ബന്ധപ്പെട്ട വകുപ്പുകളിൽ KRWSA അടക്കണം. ഫണ്ട് അനുവദിക്കുന്നതിന് താഴെ പറയുന്ന രേഖകൾ ബില്ലിനോടൊപ്പം സമർപ്പിക്കേണ്ടതാണ്.

ബില്ലി	സമർപ്പിക്കേണ്ട രേഖകൾ	ഉത്തരവാദിത്തപ്പെട്ട ഉദ്യോഗസ്ഥൻ
ഒന്നാം പാർട്ടി ബില്ലി	സാങ്കേതികാനുമതിപത്രം എസ്റ്റിമേറ്റിന്റെ പകർപ്പ്	പ്രൊജക്ട് കമ്മീഷണർ/ ജൂനിയർ പ്രൊജക്ട് കമ്മീഷണർ
	നിർവ്വഹണ കരാറിന്റെ പകർപ്പ്	
	ഗുണഭോക്തൃലിസ്റ്റ്, വിഹിത സമാഹരണ റിപ്പോർട്ട്	
	ക്വട്ടേഷൻ/ടെണ്ടർ രേഖകൾ	
	കരാറുകാരന്റെ/end beneficiary യുടെ പാൻകാർഡ്, GST ഇൻവോയ്സ് ബിൽ, ബാങ്ക് പാസ്സ് ബുക്കിന്റെ പകർപ്പ്	
	മെഷർമെന്റ് ബുക്ക്, അനുബന്ധ രേഖകൾ.	
രണ്ടാം പാർട്ടി ബില്ലി	മെഷർമെന്റ് ബുക്കും അനുബന്ധ രേഖകളും, GST ഇൻവോയ്സ് ബിൽ	പ്രൊജക്ട് കമ്മീഷണർ/ ജൂനിയർ പ്രൊജക്ട് കമ്മീഷണർ
ഫൈനൽ ബില്ലി	മെഷർമെന്റ് ബുക്കും അനുബന്ധ രേഖകളും, GST ഇൻവോയ്സ് ബിൽ	പ്രൊജക്ട് കമ്മീഷണർ/ ജൂനിയർ പ്രൊജക്ട് കമ്മീഷണർ
	പ്രവൃത്തി പൂർത്തീകരണ പത്രം, Work Value Certificate	
	ജലഗുണനിലവാര പരിശോധന റിപ്പോർട്ട്	
	പ്രവൃത്തി പൂർത്തീകരിച്ചത സംബന്ധിച്ചും തുക അനുവദിക്കുന്നതിനു വേണ്ടിയും BG/SLEC/GPLAC യുടെ കത്ത്.	
	തുടർനടത്തിപ്പ് പരിപാലന നിയമാവലിയുടെ പൊതുയോഗം അംഗീകരിച്ച തീരുമാനം പകർപ്പ്	
	ഗുണഭോക്തൃ പട്ടിക	
	BG/SLEC/GPLAC നൽകുന്ന സോഷ്യൽ ഓഡിറ്റ് റിപ്പോർട്ട്.	

സ്ഥാപനങ്ങളിലും, പൊതു ഇടങ്ങളിലും നടത്തിയ പ്രവൃത്തിയാണെങ്കിൽ ബന്ധപ്പെട്ട സ്ഥാപനം, സമിതി നൽകുന്ന കത്ത് അവസാന ഗഡു ഫണ്ട് നൽകുന്നതിനു ആവശ്യമാണ്. പദ്ധതി പൂർത്തീകരണം, കണക്ക് തീർപ്പാക്കൽ എന്നിവയ്ക്ക് ശേഷം പദ്ധതി നിർവ്വഹണവുമായി ബന്ധപ്പെട്ട രേഖകൾ KRWSA യുടെ മേഖല / ജില്ലാ ഓഫീസുകളിൽ സൂക്ഷിക്കണം. പദ്ധതി പൂർത്തീകരണ രേഖയുടെ പകർപ്പുകൾ ബന്ധപ്പെട്ട സമിതികൾക്കും,സ്ഥാപനത്തിനും, ഗ്രാമപഞ്ചായത്തിനും നൽകേണ്ടതാണ്.

കരാറുകാരൻ മുഖേന അല്ലാതെ നടത്തേണ്ടി വരുന്ന അംഗീകരിക്കപ്പെട്ട പ്രവൃത്തികൾക്ക് ഉദാ: വൈദ്യുതി കണക്ഷൻ, റോഡ് കട്ടിംഗ്,ഹൈഡ്രോ ജിയോളജിക്കൽ സർവ്വേ,സർക്കാർ

I/20214/2022

സ്ഥാപനം മുഖേനയുള്ള ബോർഡ് വെൽ നിർമ്മാണം, വെള്ളത്തിന്റെ ഗുണനിലവാര പരിശോധന...etc...etc എന്നിവയ്ക്ക് നൽകേണ്ട തുക ഗുണഭോക്തൃസമിതി അല്ലെങ്കിൽ Glac സാക്ഷ്യപ്പെടുത്തി നൽകുന്ന ഡിമാൻഡ് നോട്ടീസ്/എസ്റ്റിമേറ്റ്/ബില്ലിന്റെ അടിസ്ഥാനത്തിൽ Krwsa യിൽ നിന്നും end beneficiary ക്ക് നേരിട്ട് നൽകുന്നതാണ്.

**ബാങ്ക് ഇടപാടുകൾ**

ഗുണഭോക്തൃ വിഹിതമായും പഞ്ചായത്ത് വിഹിതമായും സമാഹരിക്കുന്ന തുക നിക്ഷേപിക്കുന്നതിന് ഗ്രാമപഞ്ചായത്ത് പ്രസിഡണ്ട്, സെക്രട്ടറി എന്നിവരുടെ പേരിൽ ദേശസാൽകൃത / ഷെഡ്യൂൾഡ് ബാങ്കിൽ പഞ്ചായത്ത് തല പ്രോജക്ട് ബാങ്ക് അക്കൗണ്ട് ആരംഭിക്കണം. ഈ സംയുക്ത ബാങ്ക് അക്കൗണ്ടിൽ നിക്ഷേപിക്കുന്ന ഗ്രാമപഞ്ചായത്ത് വിഹിതം, ഗുണഭോക്തൃവിഹിതം, അതിന്റെ പലിശ തുക എന്നിവ അതാത് ഗ്രാമപഞ്ചായത്തുകളിൽ KRWSA മുഖേന നടപ്പിലാക്കിയ പദ്ധതികളുടെ / കുടിവെള്ള പദ്ധതികളുടെ തുടർനടത്തിപ്പിനും പരിപാലനത്തിനുമുള്ള റിവോൾവിംഗ് ഫണ്ടായി വിനിയോഗിക്കണം. backstopping support agency എന്ന നിലയിൽ KRWSA യുടെ സേവനം ഗ്രാമപഞ്ചായത്തിന് ആവശ്യമുണ്ടെങ്കിൽ ടി തുക അതിനായും വിനിയോഗിക്കാവുന്നതാണ്.

**കണക്ക് തീർപ്പാക്കൽ**

പ്ലാൻ ഫണ്ട് വിനിയോഗിച്ചുള്ള എല്ലാ നിർവ്വഹണ പ്രവൃത്തികളും സമയബന്ധിതമായും സുതാര്യമായും പൂർത്തീകരിച്ച് KRWSA യാണ് കണക്കുകൾ തീർപ്പാക്കേണ്ടത്.

**പ്രോജക്ട് മോണിറ്ററിംഗ്**

പ്ലാൻ ഫണ്ട് വിനിയോഗിച്ചുള്ള എല്ലാ പ്രവർത്തനങ്ങളും പ്രോജക്ട് മാനേജ്മെന്റ് സിസ്റ്റം (PMS) സോഫ്റ്റ് വെയറിൽ ബന്ധപ്പെട്ട KRWSA ഉദ്യോഗസ്ഥർ പ്രവർത്തന പുരോഗതിക്ക് അനുസരിച്ച് രേഖപ്പെടുത്തേണ്ടതാണ്. ആയത് സമയാ സമയങ്ങളിൽ KRWSA യുടെ ഉയർന്ന ഉദ്യോഗസ്ഥർ അവലോകനം ചെയ്ത് പ്രവൃത്തികൾ സമയബന്ധിതമായി പൂർത്തീകരിച്ചുവെന്ന് ഉറപ്പു വരുത്തണം. പൊതുജനങ്ങൾക്കു കാണാവുന്ന വിധം KRWSA യുടെ വെബ് സൈറ്റിൽ മുഴുവൻ പദ്ധതിയുടെയും എല്ലാ വിവരങ്ങളും പ്രസിദ്ധീകരിക്കണം.

  
Director-Finance & Administration i/c  
KRWSA, Thiruvananthapuram