



KERALA RURAL WATER SUPPLY AND SANITATION AGENCY

**Name of Work : Jal Jeevan Mission – Providing Functional Household
Tap Connections – Full Coverage to Bellur Grama Panchayath,
Kasaragod District**

E-TENDER No : 001/JJM/KRWSA/RPMU/KNR/BLR/2023

**DUE DATE & TIME FOR
UPLOADING OF TENDER BY TENDERER : 04/12/2023, 06.00 PM**

TENDER OPENING DATE : 06/12/2023, 11.00 AM

NOTICE INVITING TENDER

VOLUME – I & II

OFFICE OF THE REGIONAL PROJECT DIRECTOR

KERALA RURAL WATER SUPPLY AND SANITATION AGENCY

RPMU KANNUR

KERALA STATE

TELEPHONE: 0497 2707601

Email ID : rpmukannur@gmail.com

CONTENTS

Sl. No.	Description	Page No.
a	Check list of Bidder submittals	a
b	General Tender Terms & Conditions for Kerala State E-Procurement System	b-e
Volume I		f
1.	E -Tender Notice	1-2
2.	Detailed Tender Notice	3-5
3.	Letter Submitting the Tender	6-7
4.	Particulars showing the status of tenderer	8
5.	Forms of Agreement	9-11
6.	Definitions and Interpretations	12-13
7.	Tender Conditions - Part: I - PRE-QUALIFICATION O F TENDERERS	14-27
8.	Tender Conditions - Part: II	28-39
9.	Tender Conditions - Part: III - CONTRACT CONDITIONS	40-53
10.	General Technical Specifications	54-66
11.	Format Q1 to Q8	67-76
<u>Volume II (Scope of Work)</u>		77
1.	General Information & Detailed Technical Specifications	80
<u>Other Appendix & Annexure</u>		93 onwards

Check list of Bidder submittals

(Shall be serially numbered and submitted in order along with the tender documents)

Sl. No.	Documents / Particulars	Page No.	Put mark
1	Letter submitting tender, signed copy of NIT and all bid documents and attachments		
2	Preliminary Agreement		
3	Particulars Showing Status of Tenderer		
4	*Solvency Certificate in Q4 A (form Attached)		
5	Contract License		
6	GST registration		
7	Partnership / Joint Venture details		
8	Past Experience (specify the year of completion, type, size and length of pipe)		
9	Documentary proof of experiences Serially number on 6a, 6b,....etc.)		
10	Format Q1		
11	Format Q2		
12	Format Q3		
13	Format Q4		
14	*Format Q4A		
15	Format Q5		
16	Format Q6		
17	Format Q7		
18	Format Q8		
19	CPM Schedule		
20	Bar Chart		
21	Brief description of the system offered		
22	Method of execution		
23	Balance sheet, if required		
24	Form of Declaration of non relationship as per clause 7.12		
25	MoU for pipes		
26	MoU for specials		
27	MoU and design curves for pumpsets		
28	Undertaking as per clause 7.17.1.2.2 regarding LD		

*Q4 A Mandatory in the attached form itself. Other forms will not be accepted for prequalification

Signature of the Contractor

(a)



KERALA RURAL WATER SUPPLY AND SANITATION AGENCY

General Tender Terms & Conditions for Kerala State e-Procurement System through <https://www.etenders.kerala.gov.in>

(The clauses, sentences, words etc. stricken off shall be treated not applicable to this tender)

This tender is an e-Tender and is being published online for the work/supply: **“Jal Jeevan Mission – Providing Functional Household Tap Connections – Full coverage – Bellur Grama Panchayath in Kasaragod District”**. The tender is invited in ~~ONE~~/TWO (strike off whichever is not applicable) cover system from the registered and eligible firms through e-procurement portal of Government of Kerala (<https://www.etenders.kerala.gov.in>). Prospective bidders willing to participate in this tender shall necessarily register themselves with above mentioned e-procurement portal.

The tender timeline is available in the critical date section of this tender published in www.etenders.kerala.gov.in.

A). Online Bidder registration process:

Bidders should have a Class II or above Digital Signature Certificate (DSC) to be procured from any Registration Authorities (RA) under the Certifying Agency of India. Details of RAs will be available on www.cca.gov.in. Once, the DSC is obtained, bidders have to register on www.etenders.kerala.gov.in website for participating in this tender. Website registration is a one-time process without any registration fees. However, bidders have to procure DSC at their own cost.

Bidders may contact e-Procurement support desk of Kerala State IT Mission over telephone at 0471-2577088/188/388 or 0484-2336006, 2332262 or 0497-2764788, 2764188 or 0483-273294 or through email: etendershelp@kerala.gov.in or helpetender@gmail.com for assistance in this regard.

B). Online Tender Process:

The tender process shall consist of the following stages:

i. **Downloading of tender document:** Tender document will be available for free download on www.etenders.kerala.gov.in. However, tender document fees shall be payable at the time of bid submission as stipulated in this tender document.

ii. **Pre-bid meeting:** As mentioned in the tender documents.

iii. **Publishing of Corrigendum:** All corrigenda shall be published on www.etenders.kerala.gov.in and shall not be available elsewhere.

iv. **Bid submission:** Bidders have to submit their bids along with supporting documents to support their eligibility, as required in this tender document on www.etenders.kerala.gov.in. Hard copies of all tender documents and other supporting documents shall be submitted to the tendering authority within three days of opening of the tender. However, the online submitted documents will always supersede the manually submitted hard copies of documents for tender evaluation.

(b)

v. **Opening of Technical Bid and Bidder short-listing:** The technical bids will be opened, evaluated and shortlisted as per the eligibility and technical qualifications. All documents in support of technical

qualifications shall be submitted (online). Failure to submit the documents online will attract disqualification. Bids shortlisted by this process will be taken up for opening the financial bid.

vi. **Opening of Financial Bids:** Bids of the qualified bidder's shall only be considered for opening and evaluation of the financial bid on the date and time mentioned in critical date's section.

C. Documents Comprising Bid:

(i). The First Stage (Pre-Qualification or Technical Cover based on 1 cover or 2 cover tender system):

Pre-Qualification or Technical proposal shall contain the scanned copies of the following documents which every bidder has to upload:

- i. Document 1 : Scanned copy of duly filled and signed preliminary agreement prepared in Kerala Stamp Paper worth Rs.200/-
- ii. Document 2 : Scanned copy of documents to prove eligibility criteria
- iii. Document 3: The NIT documents of the work downloaded from the website to agree with the tender conditions
- iv. Documents : Any other documents as per the requirement of the tender conditions
..... Nos (the number may vary with departments/ Tender requirement)

(ii). The Second Stage (Financial Cover or as per tender cover system):

v. The Bidder shall complete the Price bid as per format given for download along with this tender.

Kerala Rural Water Supply And Sanitation Agency doesn't take any responsibility for any technical snag or failure that has taken place during document upload.

Note: The blank price bid should be downloaded and saved on bidder's computer without changing file-name otherwise price bid will not get uploaded. The bidder should fill in the details in the same file and upload the same back to the website.

Fixed price: Prices quoted by the Bidder shall be fixed during the bidder's performance of the contract and not subject to variation on any account. A bid submitted with an adjustable/ variable price quotation will be treated as non - responsive and rejected.

D). Tender Fee and Earnest Money Deposit (EMD)

The Bidder shall pay, a tender fee and Earnest Money Deposit (EMD) or Bid Security amount as per the tender documents. The Bid security is required to protect the purchaser against risk of Bidder's conduct, which would warrant the forfeiture of security.

Online Payment modes: The tender fee and EMD can be paid in the following manner through e-Payment facility provided by the e-Procurement system:

State Bank of India Multi Option Payment System (SBI MOPS Gateway):

Bidders are required to avail Internet Banking Facility in any of below banks for making tender remittances in e Procurement System.

1	Allahabad Bank	32	Kotak Mahindra Bank
2	Axis Bank	33	Lakshmi Vilas Bank
3	Andhra Bank	34	Mehsana Urban Co-op Bank

(c)

4	Bandan Bank	35	NKGSB Co-operative Bank
5	Bank of Bahrain and Kuwait	36	Oriental Bank of Commerce
6	Bank of Baroda	37	Punjab and Maharashtra Cooperative Bank
7	Bank of India	38	Punjab National Bank
8	Bank of Maharashtra	39	Punjab and Sind Bank
9	Bassein Catholic Co-operative Bank	40	RBL Bank
10	BNP Paribas	41	Saraswat Cooperative Bank
11	Canara Bank	42	ShamraoVithal Cooperative Bank
12	Catholic Syrian Bank	43	South Indian Bank
13	Central Bank of India	44	Standard Chartered Bank
14	City Union Bank	45	State Bank of India
15	Corporation Bank	46	Syndicate Bank
16	Cosmos Bank	47	Tamilnad Mercantile Bank
17	DCB Bank	48	Tamilnadu Cooperative Bank
18	Dena Bank	49	The Kalyan Janata Sahakari Bank
19	Deutsche Bank	50	TJSB Bank (Erstwhile Thane Janata Sahakari Bank)
20	Dhanalaxmi Bank	51	UCO Bank
21	Federal Bank	52	Union Bank of India
22	HDFC Bank	53	United Bank of India
23	ICICI Bank	54	Vijaya Bank
24	IDBI Bank	55	YES Bank
25	Indian Bank		
26	Indian Overseas Bank		
27	IndusInd Bank		
28	Jammu & Kashmir Bank		
29	Janata Sahakari Bank		
30	Karnataka Bank		
31	Karur Vysya Bank		
B) Internet Banking Options (Corporate)			
1	Bank of Baroda	21	Laxmi Vilas Bank
2	Bank of India	22	Oriental Bank of Commerce
3	Bank of Maharashtra	23	Punjab & Maharashtra Coop Bank
4	BNP Paribas	24	Punjab & Sind Bank
5	Canara Bank	25	Punjab National Bank
6	Catholic Syrian Bank	26	RBL Bank
7	City Union Bank	27	ShamraoVithal Co-operative Bank
8	Corporation Bank	28	South Indian Bank
9	Cosmos Bank	29	State Bank of India
10	Deutsche Bank	30	Syndicate Bank
11	Development Credit Bank	31	UCO Bank
12	Dhanalaxmi Bank	32	Union Bank of India
13	Federal Bank	33	UPPCL
14	HDFC Bank	34	Vijaya Bank
15	ICICI Bank	35	Axis Bank
16	Indian Overseas Bank		
17	Janta Sahakari Bank		
18	Jammu & Kashmir Bank		
19	Karur Vysya Bank		
20	Kotak Bank		

(d)

During the online bid submission process, bidder shall select **SBI MOPS** option and submit the page, to view the **Terms and Conditions** page. On further submitting the same, the e-Procurement system will redirect the bidder to MOPS Gateway, where two options namely **SBI** and **Other Banks*** will be shown. Here, Bidder may proceed as per below:

- a. **SBI Account Holders** shall click **SBI** option with its Net Banking Facility., where bidder can enter their internet banking credentials and transfer the Tender Fee and EMD amount.
- b. **Other Bank Account Holders** may click **Other Banks** option to view the bank selection page. Here, bidders can select from any of the 54 Banks to proceed with its Net Banking Facility, for remitting tender payments.

**Transaction Charges for Other Banks vide SBI Letter No. LHO/TVM/AC/2016-17/47 – 1% of transaction value subject to a minimum of Rs. 50/- and maximum of Rs. 150/-.*

Any transaction charges levied while using any of the above modes of online payment has be borne by the bidder. The supplier/contractor's bid will be evaluated only if payment status against bidder is showing “Success” during bid opening

E). SUBMISSION PROCESS

For submission of bids, all interested bidders have to register online as explained above in this document. After registration, bidders shall submit their Technical bid and Financial bid online on www.etenders.kerala.gov.in along with online payment of tender fee and EMD.

For page by page instructions on bid submission process, please visit www.etenders.kerala.gov.in and click “Bidders Manual Kit” link on the home page.

It is necessary to click on “Freeze bid” link/ icon to complete the process of bid submission otherwise the bid will not get submitted online and the same shall not be available for viewing/ opening during bid opening process.

The bidders have the opportunity to revise the rates or documents uploaded by him even after submission, till the closing date of the render. Also the bidder can withdraw his offer before the closing date. Resubmission will not be possible for withdrawn bids. The option is available from "my active bids" link.



KERALA RURAL WATER SUPPLY AND SANITATION AGENCY

Name of Work : Jal Jeevan Mission – Providing Functional Household Tap Connections – Full coverage of Bellur Grama Panchayath in Kasaragod District

E-TENDER No : 001/JJM/KRWSA/RPMU/KNR/BLR/2023

**DUE DATE & TIME FOR
UPLOADING OF TENDER BY TENDERER :** 04/12/2023, 06.00 PM

TENDER OPENING DATE : 06/12/2023, 11.00 AM

NOTICE INVITING TENDER

VOLUME – I

**OFFICE OF THE REGIONAL PROJECT DIRECTOR
KERALA RURAL WATER SUPPLY AND SANITATION AGENCY**

RPMU KANNUR

KERALA STATE

TELEPHONE: 0497 2707601

Email ID : rpmukannur@gmail.com

(f)



1. E-TENDER NOTICE

The Regional Project Director, Kerala Rural Water Supply and Sanitation Agency, KANNUR invites sealed competitive electronic tenders in ~~ONE/TWO~~ level system for the following work on ~~Percentage/Item rate/Lump sum/EPCM~~ basis from Registered ~~Class A/Class B/Class C/Class D~~ contractors of Kerala Water Authority or contractors Registered in other departments in Kerala State / in other states in India/ in equivalent class and manufacturers eligible for ~~A/B/C/D~~ class license from Kerala Water Authority/PWD/CPWD/reputed contracting firms in India. The tenderers shall have experience in implementing similar works.

The tender is invited in ~~Single Cover/Double cover~~ system from the registered and eligible firms through e-procurement portal of Government of Kerala (<https://www.etenders.kerala.gov.in>). Prospective bidders willing to participate in this tender shall necessarily register themselves with above mentioned e-procurement portal.

The tender timeline is available in the critical date section of this tender published in www.etenders.kerala.gov.in.

The brief details of tender are as follows :

Tender No.	001/JJM/KRWSA/RPMU/KNR/BLR/2023
Name of Project	Jal Jeevan Mission
Name of work	Jal Jeevan Mission – Providing functional household tap connections – full coverage of Bellur Grama Panchayath in Kasaragod District.
Nature of works	Civil (Pipe line works)
Location	Bellur Grama Panchayath in Kasaragod District
Probable Amount of Contract:	Rs. 5,51,23,048/- (Tendered PAC)
Period of Completion	100 Days from date of Award of work
Source of Fund for this work:	Jal Jeevan Mission
Sale of Tender Documents	Documents are available in the site www.etenders.kerala.gov.in for free download
Tender forms received by	The Regional Project Director, Kerala Rural Water Supply and Sanitation Agency, RPMU KANNUR
Tender fee	Rs. 10,000/- + (18% GST – Rs : 1,800/- It will be paid by the contractor on reverse charge basis while filing his returns).
EMD	Rs. 2,00,000/- (Rupees Two lakhs only)
Mode of payment (Tender fee & EMD)	Online payment

Pre- bid meeting	28.11.2023 at 11.00 AM
Site visit	27.11.2023, 11.30 AM
Clarification regarding bid	All clarifications sought up to 28.11.2023 at 11.00 AM will be answered in the pre- bid meeting and published in the portal.
Corrigendum	Corrigendum if any will be published in web site
Last date and time of submission of tenders electronically to the tendering Authority	04.12.2023 at 06.00 PM
Last date and time of submission of attachments in hard copy to the tendering Authority	Within three days from the date of opening of bid electronically or such date prescribed as the date for opening of tender
Date and time of opening of tenders	06.12.2023 at 11.00 AM
Validity of Bid (Firm period)	120 days from the last date of submission of bid (electronically)
Place of execution of agreement	Office of the Regional Project Director, Kerala Rural Water Supply and Sanitation Agency, RPMU KANNUR

Interested bidders can get further details regarding the work from the office of the Regional Project Director, Kerala Rural Water Supply and Sanitation Agency, Building No.3/256, 2nd Floor, Near AKG Hospital, Talap, Kannur – 670002 (Phone : 0497 - 2707601, Email ID : rpmukannur@gmail.com).

All other relevant rules followed by KRWSA shall be applicable.

Sd/-
The Regional Project Director
RPMU KANNUR, KRWSA

KERALA RURAL WATER SUPPLY AND SANITATION AGENCY

2. DETAILED TENDER NOTICE

1. Sealed competitive tenders are invited for and on behalf of Executive Director, Kerala Rural Water Supply And Sanitation Agency, by the undersigned, from Registered **Class A/Class B/Class C/Class D** Contractors of Kerala Water Authority/Contractors Registered in Other Departments in Kerala State or other States in India equivalent class and also Manufacturers/ reputed contracting firms in India, eligible for **A/B/C/D** Class license from Kerala Water Authority/PWD/CPWD/reputed contracting firms in India, with experience in Surveying, **Designing, Supplying, Laying, testing, Trial running and Commissioning of FHTCs, pipe lines/ tanks/ WTP etc whichever is necessary as per the scope of work in volume II of NIT for the following works.**

Name of project : **Jal Jeevan Mission**

Name of work : **Jal Jeevan Mission – Providing Functional Household Tap Connections - Full coverage of Bellur Grama Panchayath in Kasaragod District**

2. Intending tenderers may enroll themselves for e-tendering in the website www.etenders.kerala.gov.in. One time registration is valid for all KRWSA tenders. The contractors who are registered for e-tendering and have valid password can only view / download the Tender Documents. The Tender Schedule shall be filled up in the prescribed format provided in tender document. For uploading the tender documents, the tenderer has to remit the amount towards cost of tender documents as well as the prescribed EMD through online payment mechanism for e-procurement system of Govt. of Kerala. Tenderers are advised to visit the “Downloads” section of e-Procurement website (www.etenders.kerala.gov.in) for detailed instructions on making online payment using **internet banking facility only**. Only those tender schedules which are downloaded from the website and uploaded after filling only will be considered. Bidders can make use of the links "help for Contractors", "FAQ", "Bidders Manual Kit" etc. in the above website for more details on registration and bid submission. For further assistance they can also contact over phone or by mail to the regional offices of Kerala State IT Mission in the addresses available in the website.

The tenders shall be submitted electronically to The Regional Project Director, Kerala Rural Water Supply and Sanitation Agency, RPMU KANNUR in the method available at the web site www.etenders.kerala.gov.in. The tenderer has to remit the amount towards cost of tender documents and EMD through online payment in time. The bid submission is allowed up to the last date and time given in this tender notice. Submitting bid documents in no way for a right or / eligibility for pre-qualification of awarding the work. The pre-qualification criteria are described in the bid document.

The bidder shall fill up the prequalification sheet, technical bid sheet and price bids in prefixed formats along with NIT, Scope of work or any other document uploaded by the Regional Project Director and upload in the website. Additional documents if any are to be scanned and uploaded in the website. The price bid shall be submitted electronically only. The tenderer shall produce before the Regional project Director, the originals of the documents uploaded including those scanned and uploaded (except price bid) with the preliminary agreement executed in the prescribed Kerala Stamp paper (Rs.200/-).

Technical Bid shall be opened in the presence of the Bidder or their authorized representative who chooses to attend the specified tender opening. After the evaluation of Technical Bid, the Regional Project Director will intimate the bidders who have qualified in Technical bid, the date and time of opening of the Price bid which will be fixed subsequently. The participating bidders can view the bid opening online and

view the rates of competitors after tender opening. Bidders are requested to furnish Telephone No/Fax No/Email ID for speedy transfer of information.

The Regional Project Director will not be responsible for any cost or expenses incurred by bidders in connection with preparation or delivery of bid or loss of any document during transit. Date extension will not be allowed without specific reasons and which is beyond the control of KRWSA. In the event of any of the specified date being declared a holiday, the event will take place at the same time and place on the next working day. All other conditions of invitation of tenders will be as per prevalent rules in Kerala Rural water Supply and Sanitation Agency.

3. Site visit: A site visit for the intending tenderers who have purchased the tender documents will be arranged by the Regional Project Director, KANNUR on **27/11/2023, 11.30 AM**. Clarifications, if any shall be asked before **18.00 PM on 04/12/2023**.
4. A pre-bid meeting will be convened by the Regional Project Director at Regional Project Management Unit, KANNUR office on **28/11/2023 at 11.00 AM** to clarify any issues raised by the intending tenderers in advance. The minutes of such pre -bid meeting shall also form part of this tender document and a copy of the same duly signed by the Tenderer /firm shall be enclosed with the tender submitted.
5. Period of completion of the work tendered will be **100 Days**.
6. The tenders shall be submitted electronically **before 04/12/2023, 06.00 PM**. The bidder shall fill up the prequalification sheet, technical bid sheet and price bids in prefixed formats along with NIT, Scope of work or any other document uploaded by the Regional Project Director and upload in the website. Additional documents if any are to be scanned and uploaded in the website. The price bids in prescribed format should be submitted electronically only. Hard copy of all other documents uploaded in original shall be submitted within three days from the date of opening of bid electronically or such date prescribed as the date for opening of tender. This shall include his pre-qualification details such as his financial standing, solvency certificate, audited statement of accounts, statement showing major projects carried out by him, income tax clearance certificate, list of his technical personnel, list of equipments available for deployment at site, certificates from reputed organizations in proof of the required experience, copy of schedule bar charts, procurement chart and CPM schedule that he has used for the completed projects, technical design and specifications of the various components he proposes to install for the present project, along with necessary drawings, specifications and literature of the machineries/equipments etc. that he proposes to supply for the project along with the procurement plan and such other details as required for this tender and as per the formats Q1 to Q8 as per Clause 7.7 and 7.8 of NIT Volume I. The cover shall also contain Preliminary agreement. The signed NIT (Volume I & II) along with copy of minutes of pre - bid meeting (signed by the tenderer), shall also be enclosed in cover together with a **checklist**. The above tender attachments shall be submitted in a single sealed cover superscripted with Tender number, Name of work and Name of contractor/ firm quoting for the work along with the covering letter. **The covering letter submitting the tender shall be in the form given in Chapter 3.**
7. The electronically submitted price bid of those contractors who have satisfied the necessary prequalification criteria as per NIT only will be opened by the Regional Project Director/Authority after giving due information about the time and date to all the selected bidders in advance and in the presence of the bidders present at the time of opening. The decision of the Regional Project Director / Authority regarding the eligibility to be selected for the opening of the financial bids will be final and **it shall not be appealable.**
8. The hard copy of tender as detailed in earlier paragraph (Para 6) should reach the office of the Regional Project Director, Kerala Rural Water Supply and Sanitation Agency, RPMU KANNUR, Bldg.No.3/253, 2nd Floor, Near AKG Hospital, Talap, Kannur - 670002 within three days from the date of submission of bid

electronically or such date prescribed as the last date for the receipt of tender. Late tenders shall not be accepted. The tenders shall be accepted only through registered post/courier service.

The tenders shall be opened electronically at **11.00 AM on 06/12/2023**. The bidders are advised to be present for the opening of tender or they can view the opening through the web site. Tenders without requisite EMD and other particulars shall not be considered further but will be retained with KRWSA.

9. The cost of tender form, for this tender is not refundable even though the tender is cancelled or rejected at any stage.
10. Those contractors who are either blacklisted or failed to complete the works, or refrain from executing the agreement and completing the work shall not be eligible to participate in this tender.

Sd/-
The Regional Project Director
RPMU KANNUR, KRWSA

3. LETTER SUBMITTING THE TENDER

(Shall be submitted in this format after filling the details along with hard copies)

Ref. No. :

Place :

Date :

From

To

The Regional Project Director
Kerala rural water Supply and Sanitation Agency
Regional Project Management Unit, KANNUR
Bldg.No.3/253, 2nd Floor, Near AKG Hospital,
Talap, Kannur – 670002.

Sir,

Sub : Submission of E Tender documents - **Jal Jeevan Mission – Providing Functional Household Tap Connections – Full Coverage of Bellur Grama Panchayath in Kasaragod District**

Ref : Your e-tender Notification No. **001/JJM/KRWSA/RPMU/KNR/BLR/2023** Dated 25/11/2023

1. I/We.....on behalf of

..... As the duly authorized person (s) in my/our official capacity as..... Of the aforesaid firm, hereby submit this tender for your consideration. I / we have read and under stood all conditions of this document in full spirit and meaning. I/We hereby agree to accept all the conditions put forth in the succeeding pages of this document without any deviations or with the exceptions, which may be expressly admitted and accepted by the tender accepting authority before the award of work. Preliminary agreement duly executed and signed in Rs. 200/- worth stamp paper is also enclosed. Copy of the specifications duly signed is also enclosed.

2. EMD for **Rs. 2,00,000/- (Rupees Two lakhs only)** has been remitted through **internet banking facility only**.
3. I / We further agree to complete the whole work in all respects within **100 Days** from the date of award of work.
4. I/We agree to keep the tender open for acceptance for a period of **120 days** from the last date prescribed for submission of tender.
5. I / We agree that Authority shall without prejudice to any other right or remedy be at liberty to forfeit the said earnest money absolutely if :
 - a) In case we fail to keep the tender open as aforesaid or make any modifications in the terms and conditions of the tender.

- b) After the Tender is accepted, I/we fail to execute the agreement as provided in the tender conditions or to commence the execution of work as provided in condition.
- 6. The tender submitted is fully in accordance with NIT and I / we agree to all NIT conditions and any other conditions prevailing in KRWSA in Toto.
- 7. I have not included any conditions in quoting for this tender.

Yours faithfully

(Office Seal)

Tenderer

4. PARTICULARS SHOWING STATUS OF TENDERER

(Shall be submitted in this format after filling the details along with hard copies)

- 4.1.1 Name of tenderer :
- 4.1.2 Address :
- Permanent :
- Present for communication :
- E-mail ID / Fax / Telephone :
- 4.1.3 Status of the tenderer/individual or Public Ltd. Co. or Private Ltd Co. or registered Partnership concern or proprietary concern :
- 4.1.4 Name and address of Chairman of Board of Directors and Managing Director/Managing Partner (in case of partnership concern) or Proprietor (in case of proprietary concern) [Memorandum of Articles and Authorization/ Partnership deed] :
- 4.1.5 Whether the tenderer is a registered Contractor of KWA/PWD/any State /Central Government Department. (CPWD, MES, Railway etc) or local bodies (ie Port Trust, District Board, Municipality or a statutory body) with Reg. No. and year, issuing authority & validity period :
- 4.1.6 Name and address of two responsible persons (preferably Senior Engineers/ Officers of a Government Department, Quasi Government organization or a local body), to whom reference can be made regarding experience and performance. :
- 4.1.7 Whether Authorization to act on behalf of the firm presented or not :

(OFFICE SEAL)

SIGNATURE WITH NAME & DESIGNATION

5. FORMS OF AGREEMENT

(A) FORM OF PRELIMINARY AGREEMENT

"Preliminary Agreement entered on this day ofTwo Thousand and Twenty Two, between the Regional Project director, RPMU KANNUR for and on behalf of Kerala Rural water Supply and Sanitation Agency of the one part and Sri.
..... (full name and address of the tenderer). Here in after called the contractor of the other part for the execution of the agreement as well as for the execution of the work of **Jal Jeevan Mission – Providing Functional Household Tap Connections – Full Coverage of Bellur Grama Panchayath in Kasaragod District.**

Kerala Rural water Supply and Sanitation Agency (KRWSA) invited tenders for the work as stated above by Notification No. **001/JJM/KRWSA/RPMU/KNR/BLR/2023** Dated **25/11/2023** in www.etenders.kerala.gov.in and the notice inviting tenders stated as follows :

Within **14 days** after the date when the acceptance of the tender has been intimated to him, the tenderer shall submit security deposit for the proper fulfillment of the same and shall execute an agreement for the work in the stipulated manner. If the contractor fails to execute the original agreement within the stipulated time, the earnest money shall be forfeited to KRWSA without any notice or in the case of the contract, fails to maintain a specified rate of progress and reason for delay is solely attributable to the contractor (to be specified in each case in the tender schedule) KRWSA shall terminate the contract as per the prevailing rules and rearrange the work at the risk and cost of the contractor and fresh tenders shall be called for or the matter otherwise disposed off.

If as a result of such measures due to the default of the tenderer to pay the required deposit to KRWSA results in any loss to KRWSA, the same will be recovered from him as arrears of revenue. The original contractor shall have no claim whatever to the sum that may be due to the contractor on this or any other subsisting contracts or under the Revenue Recovery Act or otherwise the KRWSA may decide.

NOW THESE PRESENT WITNESS AND it is mutually agreed as follows :

The terms and conditions for the said contract having been stipulated in the said tender form to which the contractor has agreed, a copy of which forms part of this agreement, it is agreed that the terms and conditions stipulated therein shall bind the part to this agreement extend to which they are abrogated or altered by express terms and conditions herein agreed to and in which accept the express provisions herein all supersede those of the same tender form.

1. The contractor hereby agrees and undertakes to perform/fulfill all the operations and obligations with the execution of the said contract work of **Jal Jeevan Mission – Providing Functional Household Tap Connections – Full Coverage of Bellur Grama Panchayath in Kasaragod District** (Here the name of the work) is awarded in favour of the contractor.
2. If the contractor does not come forward to execute the original agreement within stipulated time (maximum of 24 days, as per clause 7.22.2) after the said work is awarded and selection notice issued in his favour, the earnest money shall be forfeited to KRWSA without any notice. If the contractor commits breach of any of the conditions of the contract and not following the work schedule chart, stipulated in the NIT therein KRWSA shall terminate the contract as per the prevailing rules and rearrange the work at the risk and cost of the contractor, otherwise or loss so sustained by the KRWSA shall be realized from the contractor under Revenue Recovery Act as if arrears of land revenue as assessed, taking into consideration the prevailing PWD rate and after giving due notice to contractor. The acquisition taken by such authority officer or officers shall be final and conclusive and shall be binding on the contractor.

3. The tenderer further agrees that any amount found due to KRWSA under or by virtue of this agreement shall be recoverable from the contractor from his EMD and his properties movable and immovable as arrears of Land Revenue under the provisions of the Revenue Recovery Act for the time being or in any other manner as the KRWSA may deem fit in this regard.
4. The contractor further assures it is clearly understood that the settlement of claims either by part bills or by final bills will be made only according to the availability budget provision and allotment of funds to the Regional Project Management Unit, KANNUR under respective heads of account in which the work is sanctioned and arranged and also subject to seniority of such bills. No claim for interest or for damages whatsoever shall be made for the belated settlement of claims of bills.

IN WITNESS WHERE OF the Regional Project Director, RPMU KANNUR (here the name of the officers of the KRWSA) for on behalf of the Kerala Rural Water Supply and Sanitation Agency (KRWSA) and
the tenderer have set their hands on the day and year firm above.

Written signed by Regional Project Director, RPMU KANNUR/officers of Kerala Rural Water Supply and Sanitation Agency.

REGIONAL PROJECT DIRECTOR

In the presence of witness

- 1.
- 2.

Signed and delivered by

..... the contractor

In the presence of witness

- 1.
- 2.

Note: - The form should be presented in Rs. 200/- valid stamp paper of Govt. of Kerala.

(B) FORM OF FINAL AGREEMENT TO BE EXECUTED ON AWARD OF WORK

AGREEMENT No. :

Date :

WORKS CONTRACT

AGREEMENT entered into day of the..... Two Thousand and between of the one part and the Regional Project Director, KRWSA, RPMU KANNUR, Bldg. No.3/253, 2nd Floor, Near AKG Hospital, Talap, KANNUR – 670002 for and on behalf of Kerala Rural Water Supply and Sanitation Agency of the other part for the work of **Jal Jeevan Mission – Providing Functional Household Tap Connections – Full Coverage of Bellur Grama Panchayath in Kasaragod District** by the former for the use of the Kerala Rural Water Supply and Sanitation Agency as per accompanying, plan, specification and conditions of contract approved by the Director Technical, Kerala Rural Water Supply and Sanitation Agency.

Cost of the Contract

The total cost of the works (hereinafter referred to as the “total cost”) is Rs./- (RupeesOnly) excluding GST as reflected in accepted Bill of Quantities.

Completion time

The works should be completed within **100 Days** from the date of this Agreement. In exceptional circumstances, the time period stated in this clause may be extended in writing by mutual consent of both the parties.

Defect Liability Period

The defect liability period will be **12 months** from the date of completion and commissioning of the total works covered under this contract.

All other conditions as part of NIT document will form a part of this agreement.

Signed and delivered by the above mentioned contractor :

In presence of witness :

- 1.
- 2.

Signed and delivered by the Regional Project Director, RPMU KANNUR on behalf of the Kerala Rural Water Supply and Sanitation Agency :

In the presence of witness :

- 1.
- 2.

6. DEFINITIONS AND INTERPRETATIONS

1. '*Government*' means Government of Kerala.
2. '*Authority/KRWSA*' means the Kerala Rural water Supply and Sanitation Agency.
3. '*Project Management Unit (PMU)*' means the office of Project Management Unit, Thiruvananthapuram, Kerala Rural water Supply and Sanitation Agency. '*Regional Project Management Unit (RPMU)*' means the office of Regional Project Management Unit, KANNUR Kerala Rural water Supply and Sanitation Agency.
4. '*Executive Director (ED)*' means Executive Director (ED) at the office of Project Management Unit, Thiruvananthapuram, Kerala Rural water Supply and Sanitation Agency.
5. '*Director Technical (DT)*' means the Director Technical at the office of Project Management Unit, Thiruvananthapuram, Kerala Rural water Supply and Sanitation Agency.
6. '*Regional Project Director (RPD)*' means the Regional Project Director at the office of Regional Project Management Unit, KANNUR, Kerala Rural water Supply and Sanitation Agency.
7. '*Manager Technical (MT)*' means the Manager Technical at the office of Regional Project Management Unit, KANNUR, Kerala Rural water Supply and Sanitation Agency.
8. '*Senior Engineer (SE)*' means the the Senior Engineer at the office of Regional Project Management Unit, KANNUR, Kerala Rural water Supply and Sanitation Agency.
9. '*Project Commissioner (PC) or Engineer in charge of work*' means the Project Commissioner at the office of Regional Project Management Unit, KANNUR, Kerala Rural Water Supply and Sanitation Agency.
10. '*Departmental Officers*' mean officers of the Kerala Rural Water Supply and Sanitation Agency not below the rank of an Project Commissioner in charge of the work.
11. '*Work*' means the work / project to be done as per the description in the tender document.
12. '*Tenderer*' means person or persons, firm or partnership or company or consortium of companies submitting a tender for the work as defined under item 8 supra, either directly or through duly authorized representatives.
13. '*Contractor*' means person or persons, firm or partnership or company or consortium of companies who have entered into contract for the execution of the work.
14. '*Drawing*' means the drawing referred to in the tender documents or such other drawings as may from time to time be furnished or approved in writing by the Regional Project Director.
15. '*Site*' means lands and other places, on, under, in or through which the work is to be executed or carried out or any other place provided by the Authority for the purpose of fulfillment of the Contract.
16. '*Departmental rate*' means rate worked out by the Authority based on departmental data and Schedule of Rates plus conveyance plus 10% towards contractor's profit except on the cost of materials issued departmentally.
17. '*Specification*' means the instructions, provisions, conditions and detailed requirements contained in the tender documents.
18. '*M.D.S.S*' means Madras Detailed Standard Specifications (Latest Edition).
19. '*I.S.S*' means Indian Standard Specification, ISO means International standard Organization and BIS means Bureau of Indian Standards. '*B.S. S*' means British Standard Specifications.

20. '*Approved / Approval*' means approval in writing.
21. '*Day*' means a day from midnight to midnight. '*Week*' means seven consecutive days. '*Month*' means from the beginning of a given date of calendar month to the end of the proceeding date of the next month.
22. '*Time tested*' means the performance of an item is in such a manner that it has successfully withstood the service conditions intended originally for a continuous period of not less than 7 years in the past without having shown any unpredicted and unpleasant effect and thus has proved the worthiness beyond doubt.
23. '*Lead Partner/partner in charge*' means the partner who is authorized by an agreement executed by all partners to receive any instructions / communications/ payments from KRWSA and to attend any discussions or other activities in respect of this contract on behalf of all partners.
24. '*Testing*' when a structure / component / equipment is tested to ascertain its strength/durability /material comparison with respect to design / service loads or performance to the satisfaction of the Engineer in charge or as stipulated in the scope of work or as per ISS /BSS, or any such standards / specifications, it is defined as testing.
25. '*Trial Running*' means putting all components together with the service / design conditions so as to ascertain the individual and combined performance of all works under the scope together, with respect to the design performance for a period specified in the scope of works.
26. '*Commissioning*' means having ensured satisfaction in performance with respect to design / service conditions in testing and trial running putting the works under the scope of work into desired real service conditions from a particular moment of time continuously or otherwise as envisaged.
27. '*Training*' means imparting of training to Authority staff with sufficient practical and theoretical knowledge for the operation and maintenance of the service system/ scheme and the knowledge for attending to emergency repairs or acting appropriately on emergency situations that may arise during the life time of the system, as included in the 'work'.
28. '*Manual*' means Manual on Water Supply and treatment third edition Revised and up dated May 1999 (or the latest) of Central Public Health and Environmental Engineering Organization.
29. '*MLD/mld*' means Million liters per day. '*LPS/lps*' means Litres per second
30. '*EPCM*' means Engineering Procurement, Construction and Management.
31. '*Maintenance*' means Maintenance for specified period during the guarantee period mentioned after full commissioning of project.
32. '*ETS*' Electronic tendering system and '*E-tender*' means electronic tender.
33. '*Tender*' refers to all documents submitted by the bidder through electronic media and attachments in hard copy.
34. '*FHTC*' means Functional Household Tap Connection.

KERALA RURAL WATER SUPPLY AND SANITATION AGENCY

7. TENDER CONDITIONS : PART –I

PRE-QUALIFICATION OF TENDERERS

- 7.1 The Regional Project Director, RPMU KANNUR for, and on behalf of the Kerala Rural Water Supply and Sanitation Agency propose to arrange the following work under ~~Percentage/Item rate/EPCM/Lump Sum~~ contract basis

Name of Work : Jal Jeevan Mission – Providing Functional Household Tap Connections – Full Coverage of Bellur Grama Panchayath in Kasaragod District.

- 7.2 The successful tenderer shall be entrusted with the work of design, construction, supply, erection, pipe laying, commissioning and maintaining of all the Civil, Mechanical and Electrical components required for the completion of the project as described in the "Scope of Works" in Volume II.
- 7.3 Contractors who wish to submit their bids must have the technical knowhow, standing experience & proven reputation in the design and execution of the various works which are included in the project proposals/scope of works. They should furnish satisfactory evidence of successful completion and satisfactory performance of similar works done by them in the past (in relevant format provided in this tender document).

Engaging a consultant : In case the tenderers intend to engage a consultant for the purpose of design or any such specialized function for the contract, the name and address of such consultant together with an undertaking from the consultant shall be included in the technical bid package specifying the specialised function.

- 7.4 The tenderers who have submitted the bids, shall be considered as pre qualified for consideration of their bids further only if:

- i. The tenderer has the technical know - how, standing experience and proven reputation in similar works; the criteria for past experience counted shall be as per clause 7.17.1.2
- ii. In case of joint ventures consisting of pipe manufacturer/design consultant/and Civil / Mechanical/Electrical Engineering Contractors, where both/all are jointly and severally responsible for the proper and complete execution of the contract, the Civil Engineering Contractor shall act as the lead contractor, he shall have proven reputation in pipe laying works /construction of Water treatment Plant / similar facility and who can show satisfactory evidence of successful time bound completion and satisfactory performance of the facility as described in the scope of work. The partners shall satisfy the requirements as in clause 7.4.1.f.
- iii. The manufacturer should have adequate capacity and facility for manufacturing the required pipes, BIS certification and minimum 3 year production experience.

In case a pipe manufacturer alone is quoting for this work the firm should have the required qualification criteria among financial status and experience as stipulated in the relevant clauses.

7.4.1 In case the tender is submitted as a JOINT VENTURE:

- i. There shall not be more than four partners in a joint venture and one partner shall be designated as lead partner.
- ii. The lead partner submitting the tender on behalf of the joint venture shall (a) submit complete information pertaining to each such partner and (b) state in the covering letter attached to the

tender the name of the lead partner in charge duly authorized for submitting the tender which shall be evidenced by proper power of attorney signed by legally authorized signatories of all the partners.

- iii. Original or notary attested copy of the agreement confirming the intent of all parties to form a joint venture shall be attached with the tender. It shall also distinctly show:
 - a. The financial participation of each member of the joint venture and the responsibility of each member as regards the planning and execution of the work.
 - b. Name of the lead partner in charge who is authorized to incur liabilities and receive instructions for and on behalf of all/any of the partners of the joint venture during the entire period of the contract including any extended period, as well as for receiving payments due.
 - c. An undertaking to the effect that all the partners of the joint venture shall be jointly & severally responsible for the execution of the contract, in accordance with the terms and conditions of the contract.
 - d. A partner or a design consultant who has joined with the lead partner to compete in this bid shall not compete singly or in association with any other tenderer for this work. The tenderer while submitting his bid shall obtain an undertaking in this regard from his design consultant / partner and produce it along with the technical bid.
 - e. The aggregate of the qualification criteria of all partners together shall be sufficient to meet the requirements as if a single tender only on financial criteria.
 - f. A lead partner of the joint venture shall meet at least 40% of the qualification criteria in terms of annual turnover and net worth and any other partner shall meet at least 25% of the qualification criteria.
 - g. The extent of participation of each partner shall be specified as also experience of all such partners in the relevant field. However, a partner only for design and consultancy shall not be reckoned for the purpose of clause (f) above.
 - h. Where the tender submitted is as per clause (g) above for the purpose of attaining pre - qualification as a design and management consultant of the prime contractor, then full information shall be given on the consultancy firm's proposed participation. An undertaking from the consultant for providing professional assistance to the contractor shall accompany the tender together with the complete details regarding the technical man power and experience of such consultant.
 - i. Status of persons signing the tender on behalf of the firm in the event of the tender being submitted by a firm, the person signing the tender on behalf of the firm shall state his position in the firm as to whether he is the proprietor, partner or Manager etc. He shall also furnish with the tender, the letter or other documents (in original) authorizing him to act on behalf of the firm.

7.4.2. CHANGE IN THE FIRM'S CONSTITUTION

- 7.4.2.1 In the case of contract entered into by partnership firm, any change in the constitution of the firm shall forthwith be notified by the contractor to the Regional Project Director and to the officer with whom the agreement has been executed.
- 7.4.2.2 The contractor, shall not without the previous sanction in writing of the authority accepting the tender, execute any power of attorney in respect of any matter implying this contract and any such power of attorney executed without such sanctions shall not be recognized by or be binding up on the Authority either to grant such sanction or to refuse it or revoke a sanction once given.

7.4. 2.3 In the case of partners who are in joint venture for executing the agreement, no change in the individuals of the firm shall affect the liability of the person who may sign the agreement. Any such change shall be forthwith notified by the contractor to the Agreement Authority and the Regional Project Director for information.

7.5 TENDERS TO BE IN PRESCRIBED FORM

Tenders, which are not submitted in the prescribed form, shall be summarily rejected.

7.6 HOW TO SUBMIT THE BID

The prequalification details in FORMATS Q1 to Q8, particulars showing status of tenderer shall be submitted **electronically and in hard copy**. **The price bid in FORMATS BOQ shall be submitted electronically only**. The tenderer shall also upload all pages of the NIT in proof of the understanding and acceptance of all the tender conditions.

The tender attachment such as NIT, Formats Q1 to Q8, Preliminary agreement, solvency certificate, letter accompanying the tender, deed for joint venture/partnership firm, clarifications issued, and all other supporting documents shall be submitted in hard copy and uploaded as well.

The tender attachment shall be submitted in a single sealed outer cover super scribed with tender number, name of work and name of contractor/firm quoting the work with two inner covers marked A and B.

Cover A - This sealed cover should contain preliminary agreement, Solvency and Certificate of joint venture in original or true copy attested by a Notary

Cover B - shall contain the following information documents for prequalification (including technical bid) to be submitted as part I & II. This cover also contains a checklist of all documents containing the technical bid. All the pages in the Technical Bid shall be serially numbered for each part. The tenderer shall sign all pages of NIT in proof of the understanding and acceptance of all the tender conditions and enclosed.

Solvency certificate issued within a maximum period of six months before the date of tender from scheduled bank /Tahsildar for a minimum amount of 20% of estimated PAC subject to a maximum value of Rs. 5.00 Crores should be provided unless the Tenderer is a public Limited Company.

No opportunity shall be given for providing proof of the solvency after submission of bid. Solvency certificate shall be provided in Q4A. Solvency shall be a minimum of *Rupees 1,10,24,610/- (Rupees One Crore Ten Lakhs Twenty Four Thousand and Six Hundred Ten only)*

Part I - This part should contain NIT and relevant details as per the NIT conditions. This should also contain all information required for financial pre-qualification of the tenderer, such as copies of audited account, details of works done previously, work in hand etc. and such information should be furnished in specified formats Q1 to Q8,

Part II- shall contain Design, Product information (Specifications, Manufacturers etc.) and such other required detail satisfying the requirements in the **SCOPE OF THE WORK**.

7.7 HOW TO SUBMIT PRE - QUALIFICATION BID

7.7.1 It is mandatory that each pre-qualification application shall contain the following.

- A Information called in formats Q1 to Q8 in section 7 with supporting documents submitted through electronic media.

B Annual account statement of the applicants for the three consecutive years certified by registered independent auditors prior to the financial year of this tender. If the audit report for the year is not available, the latest audit report for the three consecutive years just previous to last year shall be considered.

- 7.7.2 All financial data/monetary values entered in the formats for the works executed /works in hand should be stated in Indian rupees. For details of contract submitted in support of past experience, the contract amount in original currency should also be stated along with Indian rupees exchange rates as applicable on 30 days prior to the last date of submission of tender and as determined by the Reserve Bank of India.
- 7.7.3 All details furnished should be complete and as applicable six months prior to the last date of submission of tender.
- 7.7.4 Applicants are particularly advised to fill the details strictly as per the enclosed formats Q1 to Q8. Applications will be rejected if required details are not furnished in prescribed form and if it do not meet the minimum qualifications/requirements mentioned anywhere in this document. **Any formats furnished in lieu of prescribed formats will not be accepted.** The applicants may furnish any additional information, which in his opinion will highlight his capacity to perform, along with the attachments. The applicant shall furnish the list and number of equipments with registration numbers intended to be deployed for this work.
- 7.7.5 While, applications are under consideration, applicants and their representatives or other interested parties are advised to refrain from contacting by any means KRWSA officers on matters related to the applications under scrutiny. Applicants will not be permitted to change the substance of their applications after they have been opened. Non compliance with these provisions shall be a cause for disqualification.
- 7.7.6 No firms/ partner of any firm, consultant including design consultant or individual be, who have submitted the tender for a work shall associate with any other bidder in the particular tender. EMD in such cases shall be forfeited and both the tenders will be treated as rejected.

7.8 HOW TO SUBMIT THE TECHNICAL BID (Cover – B Part II)

- 7.8.1 There shall be a brief description of the systems offered as a prelude to the bid under the title "Brief description of the systems offered" and numbering each of the paragraphs. This shall be followed by details of the civil structures under the title "Particulars of civil works." This shall contain the particulars regarding length, breadth, total height, water depth and sizes of the different components and the specifications of the materials proposed for construction of the various parts of these components and the method of execution. The civil structures shall be deemed to include all pipelines in case of Treatment plants/ Reservoirs. The tenderer is bound to execute all the works described in NIT even though if it is not expressed in brief description of systems offered by the contractor.

The particulars of the civil structures shall be followed by details of the electrical and mechanical equipments giving a clear picture as to (i) number of each equipment /components / valves offered (ii) quoting relevant standard specifications to which the materials conform (iii) manufacturers of the various items (iv) full size capacity of the equipments (v) locations where they are proposed and so on in as much details as possible.

- 7.8.2 The details shall, wherever possible, be furnished in the form of rows and columns (Tables) for enabling a quick evaluation of the offer,
- 7.8.3 A preliminary design substantiating the above shall be enclosed.

- 7.8. 4 Drawing required for explaining any of the items above shall be prepared to scale and appended.
- 7.8. 5 deleted
- 7.8. 6 Any other information the tenderer feels essential for a better evaluation of his tender shall also be appended after the drawings.
- 7.8.7 The documents of the Technical bid as per Clause : 7.8.1 to 7.8.6 shall be arranged in the same order.
- 7.8.8 In case of pipeline work the MOU signed with the pipe manufacturers shall be enclosed
- 7.8.9 In case of work which involves supply of materials/equipments, the proposed vendors list shall be appended. The selection of vendor shall vest with the tendering authority.
- 7.8.10 The itemized schedule of works explained under the scope of works shall be prepared and a copy of the same without the rates and cost shall be furnished in the technical bid. Detailed design for construction shall be furnished after the award of the work. **The cost or rate shall not be disclosed any where in this sheet, as it shall render the tender invalid.**

7.8.11 ALTERNATE OFFERS AND DEVIATIONS

Any alternative offer deviating from the scope of work and specifications provided in the NIT will not be entertained and shall render the tender invalid.

7.9 HOW TO SUBMIT THE PRICE BID

- 7.9. 1 The price bid in format BOQ should be submitted electronically only. The cost or rate shall not be disclosed anywhere in this sheet, as it shall render the tender invalid. The price Bid shall be submitted only in the format specified for that purpose (Form BOQ).
- 7.9.2 The price bid shall not be used for expressing or putting forth any techno commercial conditions of the tender. Violation of this stipulation shall result in rejection of the tender after the opening of the price bid even if it may happen to be the lowest.

7.9.3 VARIATION OF PRICE BID

The tenderer is bound to carry out the work as per the specification at the quoted rate. Nothing inferior to specification as per the scope of work included as part of this NIT shall be acceptable. Price variation on any account shall not be permitted if not explicitly specified otherwise in this NIT and the tenderer is expected to follow sound engineering practices in his designs and cost calculations. Changes in statutory taxes/levies, if any, shall be applied on cost of pipe in case of pipeline works, involving pipe supply. In all such cases the duties, levies, and taxes in percentage that he has considered in the quoted amount and the cost of pipes shall be declared by the tenderer while submitting his price bid. Any escalation/ reduction in statutory duties and levies will be applied only on the basic price of pipes and specials. No escalation in statutory taxes, duties and levies etc. shall be allowed beyond the approved period as per the procurement schedule, accepted and included in the agreement.

7.10 ATTESTATION OF CORRECTIONS AND ADDITIONS

Care shall be taken to prepare the tenders without corrections/over writings / erasing etc. However, if any corrections, additions or pasted slips shall become necessary, the same shall be signed by the tenderer.

7.11 LANGUAGE OF THE TENDER

Tenders shall be submitted in English and all information in the tender shall be in English. Information in any other language shall be accompanied by its translation in English. However, the details as read in the English text will be governing. Failing to comply with this direction may be considered as a sufficient reason for disqualifying a tender. Any communication should be in writing. Tenderers can make correspondence with the tendering authority through E mail, by fax, or by post.

7.12 CERTIFICATE OF NON - RELATIONSHIP

1. Persons related to any officer of the Kerala Rural water Supply and Sanitation Agency, who is in charge of or having control over the work, are strictly prohibited from tendering for the work. Relationship in this respect is restricted to father, mother, husband, wife, son, daughter, brother, sister, nephew, father -in-law, brother in-law, mother- in-law, sister- in-law and first cousin of the officer concerned. The tenderers shall declare that they are not related to any officer of the Kerala Rural water Supply and Sanitation Agency who is in charge or having control over the work. Model format is attached as Annexure 1.
2. If at any stage, the above condition is found to have been contravened, the earnest money /security deposit of the tenderer shall be forfeited and contract entered into shall be cancelled and the work arranged at his risk and cost.

7.13 FIRM PERIOD OF TENDER

Tenders shall be firm for acceptance for a period of **120 days** from the last date prescribed for submission of tender. No tender can be withdrawn or altered before the firm period is over. Any tenderer who withdraws or alters the tender before the expiry of the firm period shall do so at the risk of the tenderer and the earnest money will be forfeited to KRWSA.

7.14 PERIOD OF COMPLETION

The work shall be completed in all respects within **100 Days** from the date of award of work. This period of execution is inclusive of monsoon season. The Contractor shall follow the work schedule prepared by the Tendering Authority in CPM / PERT or manually, which will be made available to the contractor in the form of Gantt chart/ AON diagram/ table format provided with the bid document to complete the work within the stipulated time period. The execution of work shall be done in monsoon season also by taking all necessary precautions.

7.15 AUTHORITY ACCEPTING THE TENDER

The final acceptance of the tender vests with the Regional Project Director, RPMU KANNUR, KRWSA which is not bound to accept the lowest tender or assign any reason for rejecting any tender. The Authority reserves to itself the right of re-advertising the tender for the work for carrying out the work in any manner that may be deemed fit, subsequent to this invitation of tender. GO (P) No. 54/2019/Fin dated 04/05/2019 will be applicable in this tender.

7.16 EVALUATION OF TENDER

The tender submitted by a tenderer/firm shall be evaluated in two phases.

Phase I : Pre – qualification of tenderers

First stage : Pre-qualification of tenderers based on :

- (a) Financial Standing
- (b) Past Experience and

(c) Organizational Capacity.

Second stage : Evaluation of technical particulars and designs as submitted for the present project according to scope of work described.

Phase II : Evaluation of price bid of the pre qualified tenderers.

7.17 EVALUATION OF PREQUALIFICATION APPLICATION

All formats, Q1 to Q8 shall be furnished with all required particulars.

7.17.1 MINIMUM ELIGIBILITY CRITERIA FOR PREQUALIFICATION.

The applicant must be a well - established contractor/ reputed firm/ manufacturer with experience and capabilities in executing works similar to the work tendered. The applicant can either be a single or a joint venture as per clause 7.4.1 of this NIT. The minimum qualification expected for eligibility for pre qualification will be based on the following.

1. Financial standing
2. Past experiences
3. Organizational capacity
4. Technical capability

7.17.1.1 FINANCIAL STANDING

In case of joint venture/ partnership, financial standing of all partners may be added together for explaining the capacity for pre -qualification subject to clause 7.4.1 of this NIT. It should be ensured by the tenderer that all the documents furnished are duly verified and authenticated by him. No additional documents will be called for or accepted after the submission of the tender to prove financial standing. (A) Net worth

1. For all works above 300 lakhs, net worth alone shall be the main criteria for qualifying the tenderer financially irrespective of the bid capacity. From certified annual accounts for the previous financial year submitted by the contractor, his net worth shall be evaluated based on what he owns and owes. The amount owned consists of total assets in the form of fixed and current assets and the amount owed are the total liabilities. The details shall be furnished in the format Q4.

The net worth of the applicant shall be more than 15 % of annual turnover (taken as average over the preceding 3 years). Also the net worth shall not be less than 10% of the average annual estimated cost of this contract. Minimum period of calculation of net worth shall be considered as one year even if the time of completion of work is less than one year. For time of completion more than one year, the net worth calculation shall be done proportionate to the actual period.

Example :

PAC - 6,00,00,000 Completion period 18 months

(A) NetWorth

1. 10% of annual estimate cost = $(6,00,00,000 / 1.5) \times (10/100) = 40,00,000$

2. 15% of the annual turn over

Minimum turn over as per clause B = 1,20,00,000

Minimum net worth = $1,20,00,000 \times 15 / 100 = 18,00,000$

Maximum of the two, Rs. 40,00,000

2. The net worth of the applicant shall be more than **Rs. 55,12,304/- (Rupees Fifty Five Lakhs Twelve Thousand and Three Hundred and Five only)**
3. In the case of joint venture, every member shall furnish credit rating from a scheduled bank, which shall be equivalent to a minimum of 10% of the estimated cost.
4. If the Net worth is less than the required amount but greater than two third of the same, then there should be an over draft facility available from a scheduled Bank amounting to twice the amount by which the net worth is less which is to be submitted in format Q.4B.

(B) Annual Turn Over

The minimum average annual turnover of the tenderer submitting this bid shall be greater than 20% of the estimated cost of the work subject to a maximum requirement of Rs. 500 lakhs.

Example:

PAC = 600,00,000 Completion period = 18 months.

Minimum annual turnover = 20% of the PAC subject to a maximum of 500 lakhs i.e.,
 $600,00,000 \times 20 / 100 = 1,20,00,000$

1. The minimum average annual turnover of the tenderer submitting this bid shall be greater than **Rupees 1,10,24,610/- (Rupees One Crore Ten Lakhs Twenty Four Thousand and Six Hundred Ten only)**
2. The average annual turnover of the tenderer shall be calculated from the certified annual accounts of the preceding 3 financial years.

Or

From the certified annual accounts of the bidder who is having the required average annual turnover for the preceding two years and turnover along with one year good financial standing during the last 5 years.

7.17.1.2 PAST EXPERIENCE

7.17.1.2.1 No experience is insisted for any components of the work costing less than 10% of the TPAC

7.17.1.2.2 A bidder who has lagged in two or more works, for which Liquidated Damages (LD) were impose in the ten year period prior to tender date, shall not be considered for pre-qualification.

Contractor shall submit an undertaking stating the details of delayed works if any, clearly certifying that he has not delayed two or more works, for which Liquidated Damages (LD) had been imposed in the past five years prior to the date of tender.

7.17.1.2.3 For any specialized nature of work (like SCADA/Telemetry/HDD/Micro Tunneling/Smart Meter etc) which is not covered under the qualification requirement, to ensure quality and better competition in tendering. The tender inviting authority can stipulate qualification requirement with the written approval of the concerned Director technical.

7.17.1.2.4 Experience of joint venture does not pre-qualify any of its partners individually. In the case of dissolution of JV a partner can claim experience only for that part of the scope of work for which he was responsible as a partner in the JV, as certified by the Agreement Authority.

It was not compulsory to mention the responsibility of a JV partner in his experience certificate in previous KRWSA contracts (prior to 28/09/2018). Hence, experience certificates issued by

the agreement authority to a JV partner as per previous KRWSA contracts shall also be considered for pre- qualification.

Past experience certificate of his own can be considered for sole/ partner of joint venture subject to clause 7.4.1 and 7.17.1.2.4 of NIT.

Experience of Joint Venture can be considered only for the same JV.

Experience as a partner of one joint venture can be considered for sole/partner of another joint venture subject to clause 7.4.1 and 7.17.1.2.4 of NIT.

7.17.1.2.5 Construction of civil structures except Water Treatment Plant (WTP) and Sewage Treatment Plant (STP):-

- a. The bidder must have experience of having successfully completed a single work (which includes any RCC structure like Overhead water tank, Ground level tank, Sump / Weir / Intake well / Framed RCC buildings / Stadium, Godowns, Subways, Tunnels, Underpass, Warf, Jetty / Bridges / Aqueduct / Culvert / Retaining wall / Water Treatment Plant / Sewage Treatment Plant, etc.) worth minimum 40% cost of major civil component included in the particular tender for his Sole / Joint Venture / Partner of the Joint Venture within the last ten years.

Annual escalation @ 5% (simple interest) will be allowed for the cost of works completed in the previous years

- b. No experience is required for components in the scope of work of projects costing less than 10% of the Tendered PAC.

7.17.1.2.6 Construction of Water Treatment Plant upto 5 MLD output capacity.

Must have constructed a Water Treatment plant in the past with any technology for a minimum of 1 MLD output capacity for his sole/Joint Venture/Partner of the Joint Venture.

7.17.1.2.7 Construction of Water Treatment Plant above 5 MLD output capacity

Must have constructed a Water Treatment Plant in the past with any technology for a minimum of 40% output capacity subject to a maximum of 40MLD for his sole/Joint Venture/ Partner of the Joint Venture.

7.17.1.2.8 Construction of water treatment Plant with modern technology (except Conventional Filters, Lamella, Plate settler, Tube settler)

- a. Must have constructed a Water Treatment Plant in the past with any Technology for minimum of 40% output capacity subject to a maximum of 40MLD for his sole/Joint Venture/ Partner of the Joint Venture.
- b. In addition to the above, Must have constructed a Water Treatment Plant in the past with similar Technology for minimum of 10% output capacity of the proposed treatment plant for his sole/Joint Venture/Partner of the Joint Venture.(If the bidder has 40% experience in the same innovative technology, no further experience in conventional technology is required).

7.17.1.2.9 Rehabilitation work of Water Treatment Plant.

Must have constructed/rehabilitated Water Treatment Plant in the past with similar Technology for minimum of 25% output capacity for his sole/Joint Venture/Partner of the Joint Venture.

7.17.1.2.10 O&M work of Water Treatment Plant.

Must have constructed/rehabilitated/Operated & maintained Water Treatment Plant in the past with similar Technology for minimum of 25% output capacity for his sole/Joint Venture/Partner of the Joint Venture.

7.17.1.2.11 Construction of Sewage Treatment Plant upto 5 MLD capacity

Must have constructed a Sewage Treatment Plant in the past with any technology for a minimum of 0.5 MLD capacity for his sole/Joint Venture/Partner of the joint Venture. Experience Certificate issued by Agreement Executing Authority of registered private firms will also be considered.

7.17.1.2.12 Construction of Sewage Treatment Plant of capacity above 5 MLD

Must have constructed a Sewage Treatment Plant in the past with any technology for a minimum of 10% capacity for his sole/Joint Venture/Partner of the joint Venture. Experience Certificate issued by Agreement Executing Authority of registered private firms will also be considered.

7.17.1.2.13 Supplying and laying of Water Supply pipes upto and including 400mm diameter pipes of any material.

For pipe laying works of any type of pipe of diameter upto 400mm, no experience will be insisted upon.

7.17.1.2.14 Supplying and laying of Water Supply pipes above 400mm and up to and including 800mm diameter pipes of any material.

- a) Experience will be insisted with respect to the highest diameter of the pipe in the scope of the work. Irrespective of its length in the scope of work, but subject to the general condition that no experience is required for components costing less than 10% of the Tendered PAC
- b) Subject to the criterion (a) above, for works with the total length of laying greater than 1000m- Must have supplied and laid a total of 1000m of 300mm or higher sized pipes of any material in the past in a single work for his sole/Joint Venture/Partner of Joint Venture.
- c) Subject to the criterion (a) above, for works where the total length of pipe line to be laid is less than or equal to 1000m- the experience is supplying & laying of 500m of 300mm or higher sized pipes of any material in the past in a single work for his sole/Joint Venture/Partner of Joint Venture is enough.

7.17.1.2.15 Supplying and laying of Water Supply pipes above 800mm diameter any material.

- a) Experience will be insisted with respect to the highest diameter of the pipe in the scope of the work, Irrespective of its length in the scope of work, but subject to the general condition that no experience is required for components costing less than 10% of the Tendered PAC
- b) Subject to the criterion (a) above, for works with the total length of laying greater than 1000m- Must have supplied and laid a total of 1000m of 500mm or higher sized pipes of any material in the past in a single work for his sole/Joint Venture/Partner of Joint Venture.
- c) Subject to the criterion (a) above, for works where the total length of pipe line to be laid is less than or equal to 1000m- the experience is supplying & laying of 500m of 500mm or higher sized pipes of any material in the past in a single work for his sole/Joint Venture/Partner of Joint Venture is enough.

7.17.1.2.16 Supply and Installation of Pumps & Motors, Transformer and other electrical equipments.

MoU with Manufacturer/Authorized Dealer and a MOU with “A Class Electrical Licensee is required.

7.17.1.2.17 Supplying and laying of sewerage pipes upto and including 400 mm diameter pipes of any materials.

The Tender Inviting Authority shall fix the experience with the approval of the Technical Sanction issuing Authority based on the requirements and local conditions so as to ensure competence.

7.17.1.2.18 Supplying and laying of sewerage pipes above 400mm and upto including 800 mm diameter pipes of any materials.

The Tender Inviting Authority shall fix the experience with the approval of the Technical Sanction issuing Authority based on the requirements and local conditions so as to ensure competence.

7.17.1.2.19 Supplying and laying of sewerage pipes above 800mm diameter pipes of any materials.

The Tender Inviting Authority shall fix the experience with the approval of the Technical Sanction issuing Authority based on the requirements and local conditions so as to ensure competence.

7.17.1.2.20 The tenderer shall submit sufficient testimonials from the clients for whom he has executed similar type of work during the past ten years. The tenderer shall also furnish past performance data of the works carried out by him in format Q1 and Q3. The tenderer shall also furnish his commitments in respect of work in hand on the date of pre-bid meeting of this tender in format Q2.

7.17.1.2.21 Certificates of experience issued by the Agreement Executing Authority or an Officer in Charge of the plant/pipeline work not below the rank of Regional Project Director of Central/State Govt/Public Sector undertakings only will be considered for evaluation. In the case of subcontractors/sublet works, experience will be reckoned only if there is provision in the original contract for subletting/subcontracting and such sub contractors are approved by the original client. Also in such cases certificates issued by original client (Not by the contractor) shall only be considered towards experience. The date of award of such works, date of agreement and period of completion as per agreement and actual date of completion should be mentioned. The certificates furnished will be verified. If required in case any poor/false performance in the work undertaken by the tenderer is evident on verification, the offer will not be further considered/processed.(In case of construction of Sewage Treatment Plant, experience certificate issued by agreement executing authority of registered private firms will also considered as provided in clauses 7.17.1.2.11 & 7.17.1.2.12.

7.17.1.3. ORGANISATIONAL CAPACITY

The Organizational Capacity of a tenderer will be judged based on data furnished by him in respect of the personnel and experience in the design of the project components, planning of project, implementation, execution of project, number & capacity of construction plants, equipment and vehicles in good working condition which he shall deploy for the project implementation in case the work is awarded to him, the details should be furnished in formats Q5 & Q6. The tenderer shall also deploy adequate number of supporting staff and any

additional plant and equipment other than those mentioned in the list as and when required for successful completion of the project.

The tenderer shall employ Technical personnel in addition to other supporting staff as detailed below for tenure of the contract for works supervision depending upon the cost of work.

a) For works, Estimated cost from Rs.5 crores to Rs. 20 crores :

1. Works Manager – 1 No. (Civil Engineering Graduate with minimum 3 years experience)
2. Site Engineer – 2 Nos. (1 No. for supervision and 1 No. for Quality Control) – (Civil Engineering Graduate with minimum 1 year experience)
3. Site Engineer – 2 Nos. (Civil Engineering Diploma holder with minimum 1 year experience)
4. Supervisor (Mechanical) (if required) -1 No. (Mechanical Engineering Diploma holder with minimum 1 year experience)

b) For works, Estimated cost above Rs. 20 crores :

1. Works Manager – 1 No. (Civil Engineering Graduate with minimum 5 years experience)
2. Site Engineer – 3 Nos. (2 No. for supervision and 1 No. for Quality Control) – (Civil Engineering Graduate with minimum 3 year experience)
3. Site Engineer – 4 Nos. (Civil Engineering Diploma holder with minimum 2 year experience)
4. Supervisor (Mechanical) (if required) -1 No. (Mechanical Engineering Diploma holder with minimum 2 year experience)

7.17.1.4 TECHNICAL CAPABILITY

(A) TECHNICAL PARTICULARS AND DESIGN

The technical particulars such as structural design of civil works/design and selection of pipes, design and selection of electrical/mechanical equipments, and their proposed suppliers/manufacturers etc. shall be in conformity with the requirements of the scope of work and technical bid package.

(A) PROJECT MANAGEMENT STRATEGY

The Contractor shall follow the work schedule prepared by the Tendering Authority in CPM / PERT, which will be made available to the contractor in the form of Gantt chart / AON diagram / table format provided with the bid document to complete the work within the stipulated time period.

7.17.1.5 All formats, Q1 to Q8 shall be furnished with all required particulars.

7.17.1.6 In case of joint venture partnership, bid capacity and financial standing and machinery and personnel of all partners may be added together for explaining the capacity for pre-qualification. It should be ensured by the tenderer that all the documents furnished are duly verified and authenticated by him. No additional documents will be accepted after the submission of the tender.

7.18 Offers are liable to be rejected if

- 1) The information given in formats Q1 to Q8 is incomplete / misleading or false (such application will be considered as non -responsive)
- 2) The facts are miss-represented. (In this case the EMD is liable to be forfeited).
- 3) The records of poor performance are found out at any time after submission of bid.
- 4) The contractors who are blacklisted or failed to complete the works, or refrained from executing the agreement and completing the work which they had agreed in the tender.

7.18.1 Tenders will be rejected if

- 1) EMD is not proper and sufficient
- 2) NIT is not accepted in Toto
- 3) If the tender is conditional
- 4) If the formats Q1 to Q8, and BOQ are not submitted.

7.19 The successful bidders who are qualified in the pre-qualification evaluation will alone be invited for attending the opening of the price bid.

7.19.1 WITNESSING OF TENDER OPENING

Only one authorized representative will be permitted to witness the bid opening at both the occasions as in clause 7 of Detailed Tender Notice in Chapter 2.

7.20 FINAL DECISION MAKING AUTHORITY

The Authority reserves the right to accept or reject any of the applications for pre qualification without assigning any reasons thereof and Authority's decision shall be final.

7.21 PERFORMANCE GUARANTEE AND ADDITIONAL PERFORMANCE GUARANTEE

Performance guarantee, the amount collected at the time of executing contract agreement, will be 5% of the contract value (agreed PAC) and the deposit will be retained till the expiry of Defect Liability Period + 28 days. At least fifty percent (50%) of this deposit shall be collected in the form of Treasury Fixed Deposit and the rest in the form of Bank Guarantee or any other forms prescribed in the revised PWD Manual

Additional Performance Guarantee will be required in all cases where quoted rate falls below 10% of the estimate cost but the maximum permissible lower limit is 25% below the estimated cost. The 10% standard exemption will be applicable to all estimates quoted below estimate cost upto 25%. If the rate quoted by the contractor is "x%" below estimate cost (where x lies above 10% and upto 25%) the performance guarantee for an amount equal to (x-10)% of the estimate amount shall be obtained from the contractor.

The tender with lowest quoted rate less than 75 % of the estimated PAC (below 25 % of estimated PAC) shall not be rejected if sufficient competition is ensured and the rate quoted by the second and third lowest bidder are also comparatively nearer the lowest bidder. The tender inviting authority shall obtain a statement from the lowest bidder quoting rates below PAC regarding the reasonableness of the rate quoted to assess that whether the quoted rates are workable. If the contractor quotes less than 75% of the estimated PAC and variation with all other quoted rates are much higher, the Tender accepting authority shall take appropriate decision based on merit.

7.22 EXECUTION OF AGREEMENTS

7.22.1 Preliminary agreement in Rs. 200/- Kerala Govt. Stamp Paper duly filled up and signed is to be enclosed in Cover A.

7.22.2 The successful tenderer shall before commencing the work, execute an agreement within **14 days** from the date of award of the work in Kerala State Government stamp paper of the required value for the due fulfillment of the contract. He shall pay for stamps, forms and legal expenses incidental thereto. Before executing the agreement, the contractor shall finalize his procurement, which shall form part of the agreement. The contractor shall also produce an MOU signed between him and the suppliers/ manufacturers of the equipments / pipes in order to prove and ensure the availability of the materials required for the work and this shall also form part of the agreement. In case the tenderer fails to execute the agreement within 14 days, fine at the rate of 1 % of contract amount subjected to a minimum amount of Rs. 1000/- and maximum amount of Rs. 25,000/- shall be levied for entering into agreement within the next 10 days after the notified period of 14 days. Tenders will be rejected and selection notice issued shall be cancelled and EMD shall be forfeited if agreement is not executed within **24 days** and work will be awarded to the next lowest tenderer. Any work recorded as done during the period between the award of work and the end of period allowed to execute agreement will be treated as an asset to KRWSA and no claim will be allowed for the selected tenderer. If the successful tenderer fails to deposit the security amount and execute the agreement as specified above, the EMD of the tenderer shall be forfeited to Authority and the work shall be arranged otherwise. If as a result of such measures due to the default of the tenderer to pay the requisite security deposit, sign contracts and take possession of the worksite, the Authority incurs any loss, the same shall be recovered from him, but it should be a savings to the Authority, the original contractor shall have no claims to the difference. Recoveries on this or any other account shall be made from the sums due to the contractor on this account or otherwise as the Authority may decide, including Revenue Recovery Proceedings, as if the loss is arrears of land revenue

7.23 COMMUNICATIONS TO BE IN WRITING

All notices, communications, references and complaints issued or made by the Authority, the Director Technical or by any such officers of the Authority and by the contractor with regard to this work shall be in writing and no notice, communications, reference of complaint not in writing shall be valid. All complaint notices, communications and references shall be deemed to have been duly made, given or sent to the Contractor, if delivered to the Contractor or his authorized agents in person with acknowledgement or posted to the address given by the Contractor or his authorized agent and such communication, if sent in service by post shall deemed to have been received by the addressee on the date on which the same should have reached such address in the ordinary course of transmission by post and in other cases, on the day on which the same were delivered or left.

7.24 ORAL AGREEMENTS NOT BINDING

The terms of contract cannot be added to varied or reduced by any oral agreements previous or subsequent to its signature. The Authority will repudiate any such oral agreement.

Regional Project Director

KERALA RURAL WATER SUPPLY AND SANITATION AGENCY

8. TENDER CONDITIONS: PART –II

8.1 TENDERS ARE TO BE IN PRESCRIBED FORM

All the submittals under this tender shall be in the prescribed form. Tenders which are not submitted in the prescribed form shall be summarily rejected.

8.2 PURPOSE OF THE CONTRACT

All the works executed/ facilities installed under this contract shall perform the services they are intended to do to the utmost satisfaction of Kerala Rural Water Supply and Sanitation Agency, without any defects whatsoever for a minimum period of **100 Days** from the date of completion and commissioning of the total works covered under this contract.

8.3 ALTERATION IN DRAWINGS SPECIFICATIONS ETC

8.3.1 The preliminary drawings and connected details enclosed are only for the reference of the tenderer. The tenderers shall conduct their own specific studies and detailed investigations based on the scope of works before offering the bid amount.

8.3.2 The Authority shall be at liberty to shift the location of structure or component of work within the periphery of the site shown in the site plan at any stage before the commencement of the actual execution of the work and the tenderer shall have no claims for any extra or enhanced rate on this account.

8.4 EXAMINATION OF THE SITE CONDITIONS, DRAWING ETC

8.4.1 The Authority does not accept any responsibility for the correctness of the description of the preliminary drawing and specifications. These are liable to alterations by omissions, deductions or additions as set forth in the conditions of contract.

8.4.2 The attached preliminary sketches, drawings, specifications, contours etc may become liable to changes at the present situation. The tenderer should verify and ascertain the correctness of these. The submission of the tender shall deem to be prima -facie proof that the tenderer has made such an examination and that this tender is based on the actual situations.

8.4.3 The tenderer shall examine carefully the proposal, drawings and specifications. They shall satisfy themselves as to the character, quality and quantities of the work to be performed, the materials to be supplied and the requirements of the contract with reference to the site and soil conditions. If the tenderer finds any discrepancies or omissions in the drawings, specifications or the tender documents or he should be in doubt as to the true meaning of any part thereof he shall make a written request to the Tendering Authority at least 15 days prior to the last date fixed for the receipt of tenders or during the pre bid meeting whichever is earlier for necessary clarifications. Clarifications, corrections or modifications considered necessary in the tender documents shall be issued by the Tendering Authority to all intending tenderers who had purchased the tender form. The last date for issuing such clarifications, corrections or modifications shall be 10 days prior to the last date for receipt of tender. The scope of works provides the requirement of Authority in this work. The information on the site conditions, sub soil investigation reports etc. as available with the Authority at present are furnished with the tender documents. The soil investigation reports, information as to maximum water level, minimum water level etc. if furnished in the scope of work have been collected from reliable sources. But the Authority does not certify the correctness of the information. The tenderers shall examine this information critically and ascertain the correctness to their satisfaction. Relying on any information without verifying the correctness/authenticity and

thereby leading himself to any loss shall be at the risk of the tenderer. Authority shall not bear any responsibility on such accounts.

8.4.4 The tenderer shall specifically note that the bearing capacity and other details of soil and sub soil indicated in Appendices is only approximate and that the Authority does not give any guarantee regarding their present accuracy. The tenderers shall carry out their own tests visual and field to ascertain the bearing pressure and other details of soil and sub soil at various points before submitting the tender, if they so desire. The Authority shall in no way be liable for payments of any extra amount on account of any variation in the actual bearing capacity or other details of soil and sub soil resulting in any changes in design of foundation of structures etc.

8.4.5 The contractor shall produce total design which should be prepared in association with any leading consultants in the field who have previous experience in handling comparable works of similar nature. However, the final concurrence/approval of the design shall vest with the Authority. The competent authority providing the design for and on behalf of the contractor shall authenticate the same in writing. The Authority by the provisions of the contract reserves the right to return the design/drawing(s) after award of work for resubmission after incorporating necessary corrections as found necessary. Any delay on account of the above shall not affect final completion period initially agreed upon.

8.5 SITE VISIT FOR INTENDING TENDERERS

The Authority shall arrange a visit to the site of the project works on a prefixed date. The intending tenderer can either select this date for his site visit or do the same according to his choice. If the tenderer intends to avail this facility he shall intimate the same to the Engineer in charge at least 3 days earlier to the proposed date of site visit. Late requests may not be entertained. The Manager Technical, Kerala Rural Water Supply and Sanitation Agency, RPMU KANNUR in charge of the work can be contacted over phone at his office in telephone number 0497 – 2707601 provided in the tender notice. His postal address is Manager Technical, Kerala Rural Water Supply and Sanitation Agency, Bldg.No.3/253, 2nd Floor, Near AKG Hospital, Talap, KANNUR – 670002.

8.6 PRE BID MEETING

A pre bid meeting will be conducted by the tendering authority on the date mentioned in the tender notice. Any queries/doubts, which the tenderers may have on the scope of work or tender conditions, shall also be cleared by e-mails / correspondence up to **06.00 PM on 04.12.2023**. Any decision regarding changes in NIT conditions / scope of work taken in the pre-bid meeting shall be final and the same will surpass the original conditions.

8.7 SELECTION OF LOCATIONS IN THE SITE

- a) In respect of structures/works other than pipeline works the proposed structures at the site shall be located in such a manner that the different structures form a compact unit leaving maximum possible area at the site to facilitate future expansion. However, there shall be adequate passage facilities in between, as the circumstances or surrounding areas may demand. Notwithstanding the above condition the tenderer is liable to make essential alterations in the layout during the time of actual execution as may be deemed fit by the Engineer in Charge at no extra cost.
- b) In case of pipe laying works along a public road, the alignment of the pipe line shall be selected giving prime importance to the following points over economy for technical advantages due to the hydraulics or other similar advantages.
- c) The various traffic along the road shall not be blocked except under unavoidable conditions, if necessary, work should be arranged at night without extra cost.

- d) Every possible effort shall be taken to see that the traffic is normal and be permitted with minimum constraints at unavoidable circumstances and need not be blocked.
- e) When blocking of traffic is unavoidable the work shall be arranged in such a manner that blockage can be lifted/relaxed in the shortest possible time under all probabilities.
- f) The alignment runs along the sides of the roads through the berm/close to one side and intrusion to the hard surface/tarred surfaces of pathway to the barest minimum extent only if unavoidable.
- g) Wherever blockage of traffic / imposition of constraints in traffic is unavoidable, prior sanction of the concerned Authority / Department shall be obtained. The contractor shall do all liaison works in such cases.
- h) Giving prior information to police / traffic department, display of caution and notice boards at appropriate places, lighting watching etc. shall be the responsibility of the contractor, but all such information shall be given through the engineer in charge of the works.
- i) Caution regarding existing underground cables of electricity, telecom and other on - ground structures like electric poles, telephone junction boxes, water pipe lines etc. shall be the contractor's sole responsibility.

8.8 MOBILISATION ADVANCE

No mobilization advance shall be paid to the contractor. However the contractor shall raise a claim for 80% of the value of the tested materials he has supplied at site, at the estimate rate or at his quoted rate whichever is less and in accordance with the breakup of payment approved as secured advance, which shall be considered by the authority in accordance with the relevant provisions of the rules for release of secured advance in KRWSA. Sanctioning of such secured advances shall be at the discretion of the agreement authority and shall not be taken as a right of the contractor.

8.9. INCENTIVE

If the works under this contract are completed ahead of the initially agreed period of completion the contractor shall be eligible for an incentive of one percent (1.0%) of the actual cost (accepted PAC) of works for every month saved subject to an overall ceiling of Rs.3.00 Lakhs. For the purpose of calculation of incentive, part of a month, if less than 28 days, shall not be considered. However no incentive shall be considered beyond the original period of completion, irrespective of the grounds on which such extension is ordered. All other conditions are as per G.O (P) No.84/97/PW&T dated 19.8.97.

8.10 PENALTY

The contractor for the work shall be liable to pay penalty for the delay in executing the agreement, commencing work etc. as per the provisions of G.O (P) No.84/97/PW& T dated 19.8.97. The Engineer in charge shall also have power to measure up the work of the contractor and later such part as shall be unexecuted out of his hands, and to give it to another contractor to complete, in which case, any expense which may be incurred in excess of the sum which would have been paid to the original contractor, if the whole work had been executed by him (of the amount by which it exceeds, a certificate in writing of the Regional Project Director, shall be final and conclusive) shall be borne and paid by the original contractor and may be deducted from any money due to him by Authority under the contract or otherwise, or from his security deposit or the proceeds of sale thereof, or a sufficient part thereof. In position of penalty shall be, no waver, without prejudice to the rights of Kerala Rural water Supply and Sanitation agency to terminate the contract as per the provisions of the agreement. All other conditions are as per G.O, (P) No.84/97/PW&T dated 19.8.97.

8.10.1 LIQUIDATED DAMAGES

Liquidated damages shall be levied at the rate of 0.5% of the cost of balance works for every one week of delay occurred in completing the whole work subject to a maximum of 10% of the contract value. Further, to ensure good progress during the execution of work, the contractor shall be bound, unless the contract provides otherwise, in all cases in which the time allowed for the work to reach any of the set stage of completion/ milestones as per the agreed time schedule of the work, exceeds one month, the contractor shall be liable to pay damages at the rate of 0.5% of the cost of balance works that should have been completed by that time, provided always that the entire damages to be paid under the provision of the 'clause shall not exceed 10% of the contracted value of work which should have been completed by then. All the damages payable under the provision of this clause shall be considered as liquidated damages, to be applied to the use of the Authority without reference to the actual loss sustained owing to the delay. Any appeal of the contractor against the liquidated damages charged against such lapses on his part shall be placed before and disposed of by the Authority.

8.11 EARNEST MONEY DEPOSIT (EMD)

A. EMD shall be in the form of DD/Call deposit from a Scheduled Bank drawn in favour of the Regional Project Director, KRWSA, RPMU KANNUR (Tendering Authority).

The EMD for this particular work is **Rs.2,00,000/- (Two Lakh only)**. No exemption shall be allowed for Govt/ Quasi govt. undertakings unless there is specific order from government / KRWSA to that effect for this particular work. Any such order received from KRWSA, if exists, shall be submitted.

Earnest Money Deposit (EMD) is collected to ensure serious participation in the bidding process and this amount will be returned soon after finalizing the lowest bidder. Taking into consideration of the fact that fixing higher amount will reduce competition the rates of EMD has been revised as follows:

Cost of work	Amount of EMD
i) Upto Rs.2 Crore	i) 2.5% of project cost, subject to a maximum of Rs.50,000
ii) Above Rs.2 Crore upto Rs. 5 Crore	ii) Rs. 1 lakh
iii) Above Rs. 5 Crore upto Rs. 10 Crore	iii)Rs. 2 lakh
iv) Above Rs. 10 Crore	iv) Rs. 5 lakh

B. FOREFEITING OF EMD

Authority shall without prejudice to any other right or remedy be at liberty to forfeit the said earnest money absolutely if :

1. In case the tenderer fail to keep the tender open as aforesaid or make any modifications in the terms and conditions of the tender which are not acceptable to the Authority.
2. After the Tender is accepted, if the tenderer fail to execute the agreement as provided in the tender conditions.

C. REFUND OF THE EARNEST MONEY DEPOSIT TO UNSUCCESSFUL TENDERER

The earnest money deposit of the unsuccessful tenderers shall be refunded after the tenders are disposed of.

D. Deleted

8.12 INITIAL SECURITY DEPOSIT AND RETENTION AMOUNTS

(Performance Guarantee, Additional Performance Guarantee, Performance Security Deposit)

The successful tenderer shall within **fourteen days** of receipt of the order of award of work (selection notice), shall deposit a sum equal to 5 (Five) percent of the contract value as security for the proper fulfilment of the work. At least fifty percent (50%) of this deposit shall be in the form of treasury fixed deposit and the rest in the form of bank guarantee and or any other forms prescribed in the revised PWD manual.

8.12.1 The Performance guarantee, Additional performance guarantee and Performance security deposit shall be applicable to this tender as per GO (P) No.429/15/Fin dated 28/09/2015, GO(P) No.19/2016/Fin dtd.03.02.2016, GO(P) No.124/2016/Fin dtd.29/08/2016, GO(P) No.168/2018/Fin dtd.02.11.2018, and GO(P) No.1/2019/Fin dtd.10.01.2019 (*Copies of GOs given separately*).

8.12.2 No exemption shall be allowed for initial security deposit and retention amounts for Govt/ Quasi Govt. undertakings unless there is specific order from government to that effect for this particular work and approved by the Authority.

8.13 INTEREST ON SECURITY AND RETENTION

8.13.1 No interest shall be payable upon the security deposit, or amounts payable to the contractor under the contract. 8.13.2 The Authority shall have the exclusive right to collect interest on all Govt. Securities or National Savings Certificates endorsed as aforesaid and all interest collected shall be credited to the accounts of the contractors and the contractor shall not be entitled to claim any sum by way of interest or profit on the said securities or National Savings Certificate, save the amount actually collected by the Authority. The interest so collected may either be refunded or adjusted against the contractor's security at the end of each financial year.

8.13.3 The Authority shall not be liable for any depreciation in the value of securities while at its charge nor for any loss of interest thereon.

8.14 REPAYMENT OF SECURITY DEPOSIT

8.14.1. For pipe laying works alone, the work will be treated as 'completed' when it is ready for commissioning of all allied civil works with anchor blocks and thrust blocks including fitting of all valves, specials etc. without any gap closing works in the pipeline alignment and after completion of testing of pipeline laid. Then completion certificate will be issued by the Engineer in charge of the work within one month. Release of performance guarantee, additional performance guarantee and performance security deposit will be as per GO(P) No.429/15/Fin dated 28/09/2015, GO(P) No.19/2016/Fin dtd.03.02.2016, GO(P) No.124/2016/Fin dtd.29/08/2016, GO(P) No.168/2018/Fin dtd.02.11.2018, and GO(P) No.1/2019/Fin dtd.10.01.2019 (*Copies of GOs given separately*).

8.14.2. If there is any reduction in the value of the security deposit by reason of any depreciation in the value of Government Securities, the contractor shall within thirty days of such reduction, make good, in cash or in pledge able securities of National Savings Certificate which shall be suitably endorsed as aforesaid any sum of sums which may be have been deducted from or realized from the Sale of his security deposit held in Government securities or any part thereof or from the security deposit held in cash, or any such by which the value of Government Securities has depreciated.

8.14.3 The refund of the security deposit as stated above shall however be, subject to the condition that if such time, where shall remain to be executed by the contractor any work as per the agreement or for the proper functioning of the system ordered during such period, the

Authority shall be entitled to withhold payment until the completion of such work, so much of the security deposit as shall in the opinion of the Agreement executing authority, represent the cost of the work so remaining to be executed.

8.14.4. Even when various deductions is made against the bank guarantee it shall be the responsibility of the contractor to attend at his cost, works which are essential to make the scheme functional.

8.15 ~~LUMPSUM AMOUNT/ITEM RATE/PERCENTAGE RATE~~ TO BE QUOTED FOR THE WORK

8.15.1 Bidders shall quote ~~lump sum amount /percentage rate/~~ Item rate for the work in the prescribed form provided in the tender document and shall be uploaded electronically. There shall not be any indication of the bid amount in any of the documents/papers of technical bid uploaded in which case the tender shall be rejected outright.

For payment purposes, upon execution of agreement by the successful bidder a payment schedule (Billing breakup) shall be prepared by the agreement authority in accordance with the sanctioned estimate of Kerala Rural Water Supply and Sanitation Agency and shall form the basis for billing.

8.15.2 GST will be applicable for this contract.

All bidders should have a valid GST registration. The rates quoted by the bidders shall include all taxes and duties, construction workers welfare fund contribution, etc. except the GST. The rate quoted **shall be exclusive of GST** which may be paid or become payable on the completed work within the scope of this tender. In other words the amount quoted shall be exclusive of GST prevailing as on the due date of the tender and other taxes at applicable rates shall be deducted from the payments to the contractor as per rules without further correspondence. Separate column is provided for quoting the applicable percentage of GST in price bid. The deductions from contractor's payment shall include Income Tax, and Labour welfare fund as per the rate in force. However this shall not mean that only this amount shall be deducted. The payments and deductions shall be made as per Circular No. 18/2019/Fin dated 01/03/2019 of the Finance (Industries and Public Works –B) Department, Government of Kerala. (*Copy of the circular is attached for reference.*). Any tax rules issued by Govt. as and when will be applicable to this tender.

8.16 PAYMENTS TO THE CONTRACTOR

8.16.1 The tenderers shall furnish a break -up for interim payments in line with form BOQ limiting the amounts of such interim payments to the actual cost of work at the various stages, along with the tender itself. The break - up of interim payments approved by the Regional Project Director shall form part of the agreement. The break - up shall be furnished in Cover B in the following manner.

- a) The breakup of payments shall be expressed as percentage of the total contract value.
- b) The breakup of payments of each individual component and sub break up for various stages of a component of the work shall be given.
- c) An amount of at least 5% of the total contract value shall be set apart for trial running and commissioning. If the trial running and commissioning is delayed, not due to the fault of contractor, after six months from the date of completion the above 5% can be released against Bank Guarantee.
- d) An amount equal to 1% of the total contract value shall be set apart for one year of maintenance period, commencing after completion and commissioning.

All such interim payments shall be in line with the percentage progress indicated in the schedule of bar chart and as achieved at site from time to time. The Authority reserves the right to

modify the percentage weight of each component of the project with respect to the total project cost based on the physical and financial implication of each of the components before the award of contract and this modified schedule, approved by the Regional Project Director shall form part of the agreement and this approved break up of cost of the project shall form the basis for part payments to the contractor. [Item No.8.1, 8.2 and 8.3 as per BOQ should be done at first along with retrofitting FHTCs for claiming 1st Part Bill as detailed below]

8.01	Surveying with Electronic total station with single prism in normal terrain and normal traffic
8.02	Identifying the existing distribution main and locating its position including earth work excavation for exposing the pipelines and back filling the trenches after inspection in the original position as per the direction of departmental officers including all labour and hire charges etc. complete.
8.03	Conducting field inspection, analysing the survey results and other data collected during field inspection, designing the pipeline network using EPANET for providing hydraulically feasible FHTCs by engaging technically qualifying experts including cost of all conveyance, hire and labour charges for computer software, printing charges etc. complete.

8.16.2 For the purposes of payments the bills are categorized into five as:

- a) Part-Bill - Running Account Bill - Work in progress.
- b) Part - Bill - Running Account Bill - Work completed commissioning pending.
- c) Part - Bill - Running Account Bill - Testing and commissioning completed.
- d) Part - Bill - Running Account Bill - Part Maintenance Period
- e) Part and Final Bill/Final Bill - Contract scope completed.

8.16.3 Part bills of categories (a) and (b) shall be paid in accordance with the accepted break up of payments after deducting the statutory deductions as sale tax, works contract tax, income tax or such other dues livable by the Government at source as per the laws prevalent from time to time during the tendency of the contract and other deductions as per the contract agreement.

8.16.4 There shall be no deductions due to retention amounts on bills of category (d) and (e).

8.16.5 Bills of category (e) shall be treated as final bill and shall be paid as per rules prevalent in the Authority after effecting the deductions of taxes, duties etc.

8.16.6 The contractor shall prepare and submit the bills for payment with details of measurements for the quantum of work done. The measurements will be verified by competent Engineer in charge of the work and transfer to Measurement Book issued by authority for this purpose and submitted to the Manager Technical in charge of the work. No work will be paid for unless thoroughly good and fully in accordance with the specifications. Should through inadvertence bad works be passed and paid for, it will nevertheless be perfectly competent, for the Regional Project Director to strike the same out of the account at any future time and recover the value at any date previous to or at the time of granting the final certificate. The Authority, however, reserves the right to decide and allow/pass the bill submitted by the contractor for payment based on the overall priorities and the delay / non - payments of part bill by the Authority within 30 days of its

submission by the contractor shall not entitle him for any compensation against the delayed payments nor shall it be taken as a reason for not maintaining the progress of the work.

- 8.16.7** Bills of value less than 10% of the total amount of the contract shall not be presented unless they are of categories c and e. There shall be a minimum period of 30 days between two consecutive bills raised by the contractor. The maximum number of on account bills including the 90% bill shall be 10 nos.
- 8.16.8** Break up for interim payment, vide Clause 8.16.1 shall form the basis of all “on account” payment, but if in the opinion of the Authority the break up furnished by the contractor is not in keeping with the proportionate value of the work at different stages, the authority may make their own assessment of the proportionate value of the work at the various stages and limit the interim payment to such assessed value.
- 8.16.9** Bill may be submitted by the contractor as soon as the stage of the work as per the break up for interim payment is completed and Engineer in charge shall take the requisite measures for having the same evaluated and the admissible claim as far shall be allowed as per Clause 8.16.5. Certified progress report of the Regional Project Director shall be an accompaniment to the bill.
- 8.16.10** From the "on account" payment full deduction shall be made for materials if any, issued by the Authority and any other dues from the contractor. The contractor shall furnish along with such bill detailed measurements and specifications of all items involving the use of cement and M S rods or steel to enable the departmental officers to check and admit the issue of the departmental materials.
- 8.16.11** "On account payments made to the contractor shall be without prejudice to the final making up of the accounts (Except where measurements are specifically noted in the measurement books as final measurement and as such have been signed by the contractor) and shall neither be considered nor used as evidence of any fact stated in or to be inferred from such accounts nor of any particular quantity of work having been executed nor of the manner of its execution being satisfactory.
- 8.16.12** From the "On account" payments, deductions shall, be made by the Authority at the rate of 1 % of the amount of bill, excluding cost of departmental material if any supplied, towards contribution to the Kerala Construction Workers Welfare Fund Board.
- 8.16.13** In case of any dispute arising out of the supply of ISO marked pipes, the Kerala Rural Water supply and Sanitation Agency shall be indemnified by the contractor, to the effect that all liabilities shall be borne by the selected contractor and the Kerala Rural Water supply and Sanitation Agency’s responsibility shall end with the payment for the measured quantities in accordance with the agreement for the work.
- 8.16.14** Interest for delayed payments: The tenderer/contractor must clearly understand that the settlement of claim either by part bill will be made only according to the availability of budget provision and allotment of funds made with the RPMU Office under the respective head of account in which the work is sanctioned and arranged and also subject to the seniority of such bills. No claim for interest or for damages whatsoever shall be made for the belated settlement of claims of bills. No such claims shall be admitted by the Authority.
- 8.16.15** As built drawings of the facilities installed shall be a prerequisite for the payment of 90% bill which will be paid on completion and testing of all the work but for trial run.
- 8.16.16** Checklist before making payment which would ensure quality of pipes and quality of work and workmanship should be adopted and its tracking should be done.

8.17. FINAL BILL

- 8.17.1** The final bill shall be submitted by the contractor within one month of the completion of the work as otherwise the Engineer in charge's measurement shall be accepted as final and binding.
- 8.17.2** The contractor shall prepare and submit detailed as laid/ built drawings of all structures, and pipelines, plants and machinery constructed/installed by him in proper scale and clearly marking all the dimensions, levels, chain ages etc. of all such structures and such as built drawings shall invariably accompany the final bill of the contractor and without such detailed as built drawings the contractors work as per this tender will not be considered as complete. The final payment shall be released only after approval of such drawings and submission of 5 (five) additional copies of such approved drawings properly prepared and bound in satisfactory manner together with two soft copies in compact discs for preservation.
- 8.17.3** If any amount which by virtue of this contract, may become due to the contractor be not claimed for payment within three months from the date on which it falls due, the same shall be placed in deposit account and if the amount as placed remains for three years thereafter, the contractor or others to whom it may be legally due shall forfeit the same and it shall be finally credited to Authority.
- 8.17.4** On no account the final payment shall be made to the contractor before production of clearance certificate of taxes and proof of submission of Income Tax returns. The contractor shall produce document of remittance of GST before final payment. The Taxes as per prevailing rate shall be deducted from the Contractor's bill. Tenderers are however advised to collect necessary clarifications from the authorities concerned for ensuring the extent of various taxes applicable to the work before quoting their rate.
- 8.17.5** The release of amounts shall not be made if there is litigation with the contractor.

8.18 PAYMENT FOR EXTRA ITEMS

Over and above the scope of the work, the agreement executing authority shall order, in writing, to the contractor to do any extra items of work and the contractor shall be bound to comply with such orders of the Agreement Executing officer. The Authority shall pay the contractor for such extra items of work at the departmental rates prevailing at the time of the execution of original agreement. If there is no departmental rate, prescribed for such extra items of work, the rate payable to the contractor for the particular items shall be the market value of the materials plus the cost of labour actually engaged for the extra items for the work at departmental schedule of rate plus the contractor's profit of 10%.

8.19 (A) PAYMENTS WHEN ALTERATIONS ARE INVOLVED

No authorized variation shall vitiate the contract. The Authority shall have the right to make any alteration in the original project proposal/designs during the progress of the work and the contractor shall be bound to carry them out. The amount agreed to for the work shall be varied by adding to or deducting there from as the case may be, the value of all authorized alterations, additions, or omissions, the valuation being made on the same basis as for the extra items.

8.19 (B) Variation in quantity:

When there is variation in tender quantity, the rate quoted in form BOQ shall be for the specific quantity as per the NIT and scope of work. However, this quantity may increase or decrease by a maximum extent of 25%. In case of the quantity increase, the contractor will be paid at the rate as given in the accepted BOQ schedule. In case of the quantity decrease, the quantity of pipe not laid thereby (i.e. the difference between the scheduled quantity and actual quantity) shall not be taken into consideration and payment will be made only for actual quantity used at site.

8.20. PRICE ESCALATION

This contract does not have provision for price escalation under any circumstances except in the case of variation in statutory taxes and levies as noted in Clause 7. 9.3. Even if extension of time of completion has been granted under this contract, under any relevant provision, no escalation in price shall be admissible.

8.21. NO CLAIMS ON ACCOUNT OF FLUCTUATION OF RATES, IDLING OF LABOUR ETC.

8.21.1 No claim shall be entertained on account of fluctuation of rates of labour and materials, railway freight, income tax etc. at any stage.

8.21.2 No claim for idle labour, due to non -supply of materials by the Authority or for any other reason shall be entertained.

8.22. TESTING OF COMPLETED WORK

All tests necessary to ensure that the structure, equipment, pipe lines and fittings which form part of the work, comply with the specifications, shall be carried out at the site at the contractor's cost. First 200m laid will be tested first in order to check the quality of pipes and work executed. After that testing can be done as per the instruction of Kerala Rural water Supply and Sanitation Agency officials. Such tests shall be carried out within one month of the completion of the work and shall satisfy the requirements included under the Technical Specifications. If the completed work or any portion thereof is found to be defective before the works executed by the contractor are taken over by the Authority, the Regional project Director will give the contractor a notice in writing setting forth the particulars of such defects, and the contractor shall forthwith make the defective part, good or replace the same for satisfying the requirements of the contract. Should he fail to do so within the time specified by the Regional project Director, the Regional project Director may make good the defective part or replace the same at the cost of the Contractor and such replacement shall be carried out by the Regional project Director to the same specifications as in the contract. In the event of contractor refusing to comply with the instructions of the Regional project Director within the specified period, the contractor is liable to be penalized as per clause 8.10 above.

8.23 GUARANTY PERIOD

8.23.1 The guarantee period for the work is 12 months after successful completion, testing, trial running and commissioning of the work.

8.23.2 If it becomes necessary for the contractor to replace or renew any defective portion of the work, the provision of this clause shall apply to the portion of the work so replaced or renewed until the expiration of 12 months from the date of such replacement or renewal or 12 months from the date of completion whichever is earlier. If the defects are not remedied within the notified time, the Regional project Director may proceed to do the work at the contractor's risk and expense, but without prejudice to any other right, which the Regional project Director may have against the contractor in respect of such defects. Until the final certificate of having completed the warranty period successfully has been issued, the contractor shall have the right of entry at his own risk and expenses by himself or duly authorized representatives whose names shall have previously been communicated in writing to the Regional project Director, at all reasonable working hours for the purpose of inspecting the work and taking notes there from and if he desires, at his own risk and expense, making any tests, subject to the approval of the Regional project Director.

8.23.3 Any defects noticed during the warranty period shall be properly rectified to the satisfaction of the Authority by the contractor at his own risk and cost.

8.24 MAINTENANCE PERIOD AND TRAINING OF THE OPERATIONS

After the completion of the work and issue of completion certificate by the Engineer in charge, the system shall be run, operated and maintained by the contractor for a period of **12 months**. The satisfactory and efficient functioning of all the components installed by the contractor for this project should be conclusively proved to the satisfaction of the Regional Project Director. During the period of maintenance, the chemicals and all other consumables and the required staff for the operations shall be supplied by the contractor at his cost. Only power charges shall be borne by the KRWSA. The contractor shall also train the Authority staff during the period of maintenance in running and maintaining the system independently and in an efficient manner i.e. during **the 12 months** maintenance period the Authority staff and contractors personnel shall be simultaneously engaged in the operation of the system.

8.25 EXTENSION OF TIME OF CONTRACT

Time is considered as the essence of this contract. Any delay due to exceptionally adverse climate conditions or other special circumstances of any kind other than default on the part of the contractor shall fairly entitle the contractor for consideration of extension of time of completion for the work without any extra claim. However, such extension shall be at the sole discretion of the employer and without prejudice to the rights of the Authority to terminate the contract treating time as the essence of the contract. The Authority is not bound to take into account any extra ordinary circumstances unless the contractor has submitted full and detailed particulars within 15 days of the incident, which affected the progress of the work. Further, any such extension granted shall not relieve the contractor from the interest on the advance, if any, drawn by him. Nor shall he be eligible for the incentive for earlier completion of the works during the extended period. All other conditions are as per G.O (P) No.84/97/PW&T dtd 19.8.97)

8.26. HANDING OVER OF WORK AND CLEARANCE OF SITE

The maintenance period shall start after successful completion and commissioning and the handing over shall be after one year of operation and maintenance period.

8.26.1 The contractor shall hand over all works executed under the contract to the Authority complete in all respects and to the satisfaction of the Regional Project Director at the end of satisfactory completion of the maintenance period.

8.26.2 The Regional Project Director shall determine the date on which the work shall be regarded as having been completed as contemplated in sub clause above and shall, in support of his determination, grant a certificate to the contractor on an application being so made to him, that the work was duly executed and completed in all respects, on a date to be specified in the certificate and such certificate shall for all purposes be deemed to be the conclusive proof of the date on which the work was so completed. The Regional project Director shall also from time to time determine the date on which any particular stage of the work shall have been completed and shall, on application, grant a similar certificate to the contractor who shall be bound to follow all such determination in all subsequent dealings with the Authority on the subject matter of the contract in regard to the work.

8.26.3 On completion of the contract, the contractor shall clear away and remove from the site all construction plant, surplus material, rubbish, debris and all temporary works of every kind and leave whole of this' site and work in a neat and clean condition to the satisfaction of the Regional Project Director. No final payment in settlement of the account of the work shall be made to the contractor until, in addition to any other condition necessary for such final payment, the site

clearance shall have been effected by him, and in the event of the failure of the contractor to comply with the provision of this Sub Clause within 7 days after receipt by' him of a notice to that effect, such clearance may be made by the Regional Project Director at the expense of the contractor and in all such cases the Authority shall not, in any way be liable for any loss or damage to any property of the contractor left at the site caused by such removal, there from and such removal may without prejudice to any other mode of removal be effected by means of public sale of such materials and property or by such other means as may be deemed fit and convenient to the Regional Project Director.

8.26.4 The contractor shall also furnish the following on instructions from the Regional Project Director :

1. Photographs of different stages of all components and special type of works taken during the course of execution (at least at ten instances and not less than a total of 60 photos)
2. Video taken at different stages during progress of works (at least thrice during the critical execution events and completion period).
3. 3-Dimensional models (1 set) and perspective drawings (5 copies) prepared for the entire scheme.
4. 4 Colour copies of as laid maps of pipe lines and also it's soft copy saved in DVD.

8.27. SETTLEMENT, ARBITRATION OF DISPUTES AND NON APPLICABILITY OF ARBITRATION

8.27.1 Settlement of disputes by Arbitration shall not be applicable to this contract.

8.27.2 In the case of any disputes arising between the parties to this contract on any of .the matters covered under this contract, the same shall be settled solely by a competent court having jurisdiction within the State of Kerala, and by no other Court.

The Regional Project Director

KERALA RURAL WATER SUPPLY AND SANITATION AGENCY

1. TENDER CONDITIONS: P ART – III

CONTRACT CONDITIONS

9.1 LAW GOVERNING THE CONTRACT

- 9.1.1** All contracts or terms thereof entered into between the Authority and the contractor under these conditions of contract shall be governed and regulated in general by the relevant laws in force in the territory of India relating to contracts.
- 9.1.2** The contractor shall strictly conform to the provisions, for the time being in force, of any laws relating to works or any regulations and bye-laws made by any local authority or any water and lighting companies or any undertakings within the limits of the jurisdiction of which it is proposed to execute the work or to obtain connection with their systems or undertakings for the purpose of such work, and where the contractor considers that variations in the drawings or specifications of such work are necessary to enable him to comply with the provisions of the law or regulations or bye-laws, as aforesaid, he shall give to the Agreement Executing Authority and the Regional Project Director a notice in writing specifying the variations, and no action in this behalf shall be taken by the contractor until he receives instruction in writing from the Regional project Director in respect thereof. The Contractor shall be bound to give to the authorities concerned such notices as may be provided in the law, regulations or bye-laws as aforesaid, and to apply all fees and taxes payable to such authorities in respect thereof.

9.2 COMMENCEMENT OF WORK

- 9.2.1** The contractor shall commence the work within 20 days after the receipt, by him, of an order in writing to this effect from the tendering authority and shall proceed with the same with due expedition and without delay, except as may be expressly sanctioned or ordered by the tendering authority or be wholly beyond the contractors' control. If the contractor fails to start work within the time specified by Kerala Rural Water Supply and Sanitation Agency after signing the agreement or fails to maintain the specified rate of progress, the security deposit shall be forfeited to Kerala Rural Water Supply and Sanitation Agency and the matter will be disposed of suitably by the Authority. If such measure results in any loss to Authority, such loss shall be recovered from the contractor as arrears or revenue but should it be a savings to the Authority, the original contractor shall have no claim whatsoever to the difference. Recoveries on this or any other amount will be made from the sum that is already due or may become due to the contractor on this or any other existing contracts or under the Revenue Recovery Act, or otherwise as the Authority may decide.
- 9.2.2** It shall be the joint responsibility of KRWSA and the contractor to get appropriate sanction from the related authority.

9.3 OCCUPATION OF LAND

No land belonging to or in possession of the Authority shall be occupied by the contractor without the permission of the Authority. The contractor shall not use or permit to use such land occupied by him for the purpose other than the execution of the works.

9.4 WATER, POWER AND APPROACH ROAD

The contractor shall, at his own cost, make arrangements for obtaining supply of water and power necessary for the work.

- 9.4.1** The contractor must arrange his own supply of water at his own expense, for the whole execution of the work

- 9.4.2** The Authority shall render necessary assistance to the contractor for obtaining the power connection, but the expenses for such connections and Electrical Energy charges shall be borne by the contractor.
- 9.4.3** For testing of pipelines and water retaining structures during the progress of work, the contractor must arrange his own supply of water.
- 9.4.4** The Authority does not undertake to construct or make available any approach road or other means of approach to the proposed work site and the tenderer shall get acquainted with the available means of approaches to the proposed site and quote for the various items. The Authority shall not be liable for any claim raised later, on the plea of non – availability or non-access to the site.

9.5 TEMPORARY SHEDS AT WORKSITE

- 9.5.1** The contractor shall at his own expense, provide himself with site office sheds, store ho use and yard in such situations and in such number as is requisite, in the opinion of the Regional project Director, for efficiently carrying out the work and the contractor shall keep at each of such sheds, store houses and yards, sufficient quantity of materials and plant in stock so as not to delay the carrying out of the work with due expedition and the Regional project Director and his assistant shall have at all reasonable times, free access to the said sheds, store houses and yards for the purpose of inspecting the stock of materials and plant stored therein, and any materials or plant objected to by the Regional Project Director shall be forthwith removed from the shed, store house or yards by the contractor. The contractor shall at his own expense provide and maintain suitable arrangements and equipment as may be deemed necessary by the Authority for the proper execution of the work.
- 9.5.2** When temporary sheds, stores etc. Put up by the contractor are no longer required in the opinion of the Authority, the contractor shall remove them at his own expense and in such manner as the Regional Project Director may direct. In the event of any failure on the part of the contractor to remove any such temporary work, the Regional Project Director shall cause the same to be removed and all the costs of such removal including the cost of supervision and other incidental charges shall be recovered from the contractor.
- 9.5.3** If temporary huts provided by the contractor on the land of the Authority for the accommodation of labour engaged by him in connection with the work are no longer required after the completion of the work, it shall be the duty of the contractor to hand over to the Authority vacant possession of the said land, and if the contractors labour refused to vacate and has to be evicted by the Authority, all expenses incurred by the Authority in connection therewith shall be met by the contractor or be recovered from him.

9.6 SETTING OUT

- 9.6.1** The contractor shall be responsible for the true and proper setting out of the works and for the correctness of the position, levels, dimensions and alignments of all parts of the work and for the provision of all necessary instruments, appliances and labour in connection therewith. If at any time during the progress of the work, any error shall app ear or arise in the position, levels, dimensions or alignments of any part of the work, the contractor on being required to do so by the Regional Project Director shall at his own expense rectify such error to the satisfaction of the Regional Project Director. The checking up of any setting out or any line or level by the Regional Project Director or his assistant shall not in any way relieve the contractor of his responsibility for the correctness thereof and the contractor shall carefully protect and preserve all bench marks, site and rails, pegs etc. used in setting out the work.

9.6.2 The contractor shall keep at his own cost all portions of work free from water or dampness due to spring, seepage or inclement weather and in a neat and sanitary condition.

9.7. EXECUTION OF WORK

9.7.1 The decision of the Regional Project Director shall be final, conclusive and binding on all questions relating to the meaning of drawings and specifications and to the quality, workmanship and materials used on the work.

9.7.2 The whole of the work shall be executed in perfect conformity with the specifications and drawings of the work approved by the Authority. If the contractor performs work in a manner contrary, to the specifications and drawings or any of them, he shall bear all costs arising or ensuing there from and shall also be liable to the Authority for any loss.

9.7.3 The whole of the work specified and provided for in the contract or that may be necessary to be done in order to form and complete any part thereof shall be executed in the best and most substantial workman like manner with materials of the best and approved quality of their respective kinds, according to the particulars contained in or implied by the specifications and as referred to in any additional particular instructions and drawings as may be found requisite to be given during the execution of the work and to the entire satisfaction of the Regional Project Director.

9.8. WORK DURING NIGHT AND SUNDAYS AND HOLIDAYS

9.8.1 The contractor shall not carry out any work between the hours of sunset and sunrise without the previous permission of the Regional Project Director or his assistant in writing.

9.8.2 No work shall be done on Sundays and holidays without the permission of the Regional Project Director or his assistant.

9.8.3 However, when work is unavoidable or necessary for the safety of life, property or works, the contractor shall take necessary action forthwith and report to the Regional Project Director immediately.

9.9 FACILITIES OF INSPECTION

9.9.1 The contractor shall afford the Officers of Kerala Rural Water Supply and Sanitation Agency every facility for entering in and upon any portion of the work at all hours for inspection or for any other purpose and shall provide all labour, materials, planks, ladders, pumps, appliances and things of every kind required for the purposes aforesaid and the Director Technical or his assistant shall at all the times have access, free of cost, to every part of the work and to all places at which materials for the work are stored or being prepared.

9.9.2 The contractor shall give at least seven days notice in writing to the Regional Project Director and his Assistant whenever any work or materials are intended to be covered up in the earth in bodies or walls or otherwise to be placed beyond the reach of measurements so that the work may be inspected or the correct dimensions thereof may be taken before the work is so covered or placed beyond the reach of measurement and where the contractor defaults to give such notice the same shall at the opinion of the Regional project Director or his assistant be uncovered and measured at the expenses of the contractor or in the alternative, no payments shall be made for such work or materials.

9.9.3 Should the Director Technical or any other Engineer / Supervisor authorized in writing by him to supervise the work, at times, consider it necessary for the purpose of enabling him to make any inspection or tests or analysis or to verify or ascertain the quality or strength of any part of the

work or of any materials the contractor shall if and when so required to do by the Regional Project Director or the person authorized as aforesaid, open up the work or the materials for inspection or testing or analysis, or pull down, or pull out the work into any number of parts and make such openings into, under or through any part of the work, as may be directed and provide all things which in the opinion of the Regional project Director or the person authorized as aforesaid, may find necessary to enable the inspection or tests or analysis of the work or any part thereof or of the materials or workmanship to be made and the contractor shall close up, cover, re-build, and make good the whole at his own cost, as and when directed by, and to the satisfaction of the Regional project Director, provided always that the work, in the opinion of the Regional project Director is found to be satisfactory and in accordance with the contract, the expenses incurred by the contractor for such examination, inspection or test shall, upon a certificate in this behalf by the Regional Project Director, be borne by the Authority.

9.10 SUSPENSION OF WORK

- 9.10.1** The contractor shall not suspend any work without the prior written permission of the Regional project Director in charge of the work under any circumstances. Any such suspended work shall be treated as incomplete and abandoned by the contractor and the Authority shall have the right to get such works completed through any other manner at the risk and cost of the contractor.
- 9.10.2** The contractor shall, on an order issued by the Regional Project Director that for any reason the work shall not be commenced or shall be suspended or stopped before completion, the contractor shall be paid for the work actually done and materials actually supplied up to the date of stoppage but the Authority shall be held in no way responsible for any further liability.

9.11 ALTERATION IN THE WORK TO BE AUTHORISED

- 9.11.1** No alteration in, or additions to, or omissions from or abandonment of any part of the work shall be deemed to be duly authorized except under written instructions from the Regional Project Director and it shall be the duty of the contractor to obtain in time such written instructions in every case.
- 9.11.2** If any work over and above that in the contract is required to be executed at the site the contractor shall have no right to be entrusted with the execution of the work and the same may be carried out through another contractor or contractors or by other means at the discretion of the Authority.
- 9.11.3** The Regional Project Director shall have full powers to send persons upon the premises to execute fittings, other works etc., not included in the contract for whose operations the contractor shall afford every reasonable facility during ordinary working hours, provided that such operations shall be carried out in such a manner as not to impede the progress of the work, included in the contract, but the contractor shall not be responsible for any damage which may happen to or be occasioned by any such fittings or other works, provided that he complies with the Regional Project Director's instructions in connection there with and provided that the damage is not caused by himself or his employees. The contractor shall, at all times, cooperate, assist, attend on, and afford facilities for such specialists, as may be employed by the Regional Project Director or other works, in connection with the work. The contractor shall also cause such special work or protect it as instructed to avoid injury during progress of the work. For failure, so to protect, the contractor must make good any damage caused. If any part of his work depends for proper execution upon or results from the work of the other contractor, the former shall inspect and promptly report to the Regional Project Director any defect in the work of the latter

likely to render it unsuitable for proper execution and results. The failure of the contractor entrusted with the work so to inspect and report shall, for all purposes be deemed to constitute an affirmative approval of the work of the other contractors as being fit and proper for the receipt of his work, except as to defects which may develop in the work of the latter contractors after the execution of his work.

9.12 PRECAUTIONS DURING PROGRESS OF WORK

- 9.12.1** The contractor shall be responsible to see that the levels, profiles, bench marks, masonry pillars or other marks set up by the Authority for guidance in the execution of the work are not disturbed, removed or destroyed and if any such marks as in the opinion of the Regional Project Director or his assistant, found disturbed, removed or destroyed, they will be replaced by the Authority at the cost of the contractor.
- 9.12.2** During the execution of the work, the contractor shall at his own cost provide adequate materials for all works relating to shoring, timbering, strutting, scaffolding etc. and execute the same in such a way as to ensure, in abundant measure, the stability and safety of all structures, excavations and works and further ensure that no physical injury or harm is likely to be caused to any person or no damage or loss is caused to any property. When two or more contractors are engaged on work in the same vicinity, they shall work together in a spirit of co-operation and accommodation. The contractor shall not take or cause to be taken any steps or action that may cause disruptions, discontent or disturbance to the works, labour and arrangement of other contractors in the neighboring or other project localities. In case of any difficulties amongst the contractors, the Regional Project Director shall conduct his work so far as it affects the others.
- 9.12.3** Existing roads or water courses shall not be blocked, cut through, altered, save to the extent permitted by the Regional Project Director. All compensation claimed by the authorities concerned for any unauthorized closure, cutting through, alteration, diversion or obstruction to such roads or water courses by the contractor be deducted from any sums which is due to or may become due to him in terms of the contract, or otherwise according to law.
- 9.12.4** The contractor shall be responsible for taking all precautions to ensure the safety of the public, whether on the property belonging to the Authority or others and shall post such look-out men, as may in the opinion of the Regional Project Director, be required to comply with the regulations pertaining to the work.
- 9.12.5** The contractor shall be responsible for safety arrangement of all equipment used for construction and shall employ trained workmen conversant with the safety regulations. The contractor shall employ only tested equipment and tools for safety and shall periodically repair them to the satisfaction of the Regional Project Director. All test certificates shall be made available to the Regional Project Director. If at any time, in the opinion of the Regional Project Director or his assistant, this provision is not complied with the contractor shall forthwith replace equipment and tools.
- 9.12.6** The contractor shall display notices and arrange for proper fencing at such places where hazardous work is being carried out. The contractor shall provide at his own expense on the work to the satisfaction of the Regional Project Director proper and sufficient firefighting equipment, first aid appliances etc. which shall at all times be available for use.
- 9.12.7** The contractor shall at all times comply with all rules and regulations made by the Government, local bodies and such directions as may be issued by the Authority from time to

time in regard to safety, first aid and health measures. The contractor shall be legally and financially liable for any lapse in taking precaution during execution of works.

9.13. PROCEDURE TO RECTIFY DEFECTIVE WORKS

- 9.13.1** If it shall appear to the Regional Project Director or his assistant, at any time during the progress of the work or at any time prior to the expiration of the guarantee period of the work, that any work has been executed with unsound, imperfect or unskilled workmanship or with materials of inferior description, or that any materials or articles provided by the contractor for the execution of the work are unsound or of a quality inferior to that contracted for, or otherwise not in accordance with the contract, the contractor shall, on demanding in writing by the director Technical or his assistant to specify the work, materials or articles, complained of and within the period of time mentioned in the demand, pull down, take up, or take out the work so complained of or objected to, remove from the site or separate from other materials or sort out the materials or articles or part thereof shall have been included any (on account) payment to the contractor, the same shall be taken in to account and deducted from any subsequent payment due to the contractor. The contractor shall also remove from the work and site any equipment fixed or otherwise objected to by the Regional Project Director or his assistant or any other persons authorized in writing by him.
- 9.13.2** The contractor shall forthwith rectify or remove and reconstruct the works so specified either in whole or in part, as the case may require, or as the case may be, and provide proper and suitable materials or articles for material or articles complained of or objected to. If the contractor fail to remedy any defect within the period specified in demand mentioned in sub clause above and in the manner required, or if he shall fail to remove from the site any materials or articles condemned as unsound or otherwise not in accordance with the specifications or to substitute suitable articles for the materials complained of or objected to, the Regional Project Director or his assistant may cause such work to be carried out and such material s or other articles to be replaced b y such means as he think fit, and all expenses consequent thereon, or incidental thereto, auxiliary thereof, shall be met by the contractor and borne by him and shall be recoverable from him by the Authority or may be deducted by the Regional Project Director from any moneys due or that m ay thereafter become due to the contractor.
- 9.13.3** Should the Regional Project Director consider that the work, although not executed in strict accordance with the specifications may be allowed to stand, payment for the same shall be made at such reduced rate as may be fixed but this procedure is quite optional on his part and shall have the concurrence of the Director technical.
- 9.13.4** In case of quality of work done is found to be poor, contractor will be liable to compensate for cost of rectification/replacement, and shall be blacklisted from participating in future tenders

9.14 SUPPLY & TESTING OF MATERIALS

- 9.14.1** The Contractor shall supply all the materials including pump sets, compressors, electrical panel boards, electrical and wiring materials, pipes and specials covered under the contract at his own cost. The pipes, specials, pumps etc. should be tested at the factory by one of the Third party inspection agencies acceptable to KRWSA and witnessed or by the technically qualified officers of KRWSA if the contract value exceeds Rs. 100 lakhs and by departmental officer deputed by KRWSA if the contract value is less than Rs. 100 lakhs. Inspection certificates should be produced along with the materials. This third party inspection is mandatory for all pipes, specials and pumping and electromechanical equipments supplied by the contractor. Also ISI/ISO marked materials should alone be accepted, wherever ISI/ISO specifications are available for such

item. In respect of ISO marked pipes the contractor shall furnish third party inspection certificates from internationally recognized inspection agencies at no extra cost to the KRWSA. Any disputes between the contractor and the supply in fixing the inspection agencies shall be a matter for settlement among themselves and the KRWSA shall not be a party to such disputes. The amount quoted shall be inclusive of the cost of all materials and inspection as specified herein. Qualified officers/Agency engaged by Regional Project Director according to KRWSA norms will be engaged for pre delivery inspection of materials conducted at the manufacturing unit.

9.14.1.1 All materials shall be supplied by the contractor in a phased manner as per the phased supply schedule prepared by the agreement executing authority. Quantity and time of each supply shall be specifically mentioned in this schedule in tune with the time of completion.

9.14.1.2 Schedule for phased supply of pipes and specials shall be prepared by the agreement executing authority based on the following criteria:

- a) Targeted progress of pipe laying works
- b) Availability of permission from other agencies (PWD, NH, NHAI, KSTP, KRFB, Corporation, Panchayath, etc.) for laying pipes

9.14.1.3 Each supply of material shall be done by the Contractor only after getting written instruction from the Engineer in charge concerned.

9.14.1.4 The Regional Project Director in - charge shall direct the Contractor to place supply order in each phase after evaluating actual progress of laying of pipes supplied in the previous phase.

9.14.1.5 Agreement executing authority shall have the authority to modify the schedule for phased supply of remaining materials during the progress of work, if there is variation from the targeted progress.

9.14.1.6 On each supply, Contractor may submit bills for materials supplied not exceeding 80% of estimate rate /quoted rate of materials, whichever is less.

9.14.2 Before using any material for the work, the contractor at his own cost, shall submit to the Regional Project Director for his approval such samples of materials as are proposed to be used. The materials shall strictly conform to the specifications approved by the Authority. Notwithstanding anything contained in this clause, the contractor shall be held fully responsible for the quality and soundness of all the materials and machinery that are supplied by him for execution of the work and completion of the project and the Regional Project Director's approval and inspection by third party inspection agency before delivery shall not in any way absolve him of his responsibility in this matter.

9.14.3 The contractor shall test or obtain the approved analysis of or weigh all materials required by the specification to be tested or analyzed or weighed where so required by the Regional Project Director and shall, if any when so required to do, test the whole or each part of the work or the materials in such manner at such times and such place or places, whether before or by the specifications or as may be directed by any of the persons aforesaid.

9.14.4 The contractor shall, if and when so required by the Regional Project Director to do, prepare and /or submit samples of works and materials for the approval of the Regional Project Director such samples shall be retained by the Regional Project Director and no materials which are required to be tested or analyzed or weighed or of which samples have to be submitted, shall be used in the work, until tests, analysis, weights or samples as the case may be shall have been approved in writing by the Regional Project Director.

9.14.5 All materials for the work must comply with the requirements or specifications laid down in the tender form and must satisfy the tests and / or analysis laid down in the specifications of the Bureau of Indian Standards/International Standards Organization or such other recognized specifications as the Regional Project Director may direct as being equivalent thereto, and in either case, with such additional tests and I or analysis as the Regional Project Director may order or in the absence of such standards or specifications, with such requirements, tests and analysis as in the opinion of the Regional Project Director, are fair and suitable.

9.15 TOOLS AND PLANT SUPPLIED BY AUTHORITY

9.15.1 It shall be the duty of the contractor to provide adequate tools and equipment needed to do the work efficiently and expeditiously.

9.15.2 No extension of time will be granted for delay in the procurement of construction equipment and / or spare parts by the contractor.

9.15.4 The contractor shall take responsible care of all tools and plant belonging to him and the Authority shall not be liable for any damage or loss caused at the time of work.

9.16 SUBLETTING OF CONTRACT

The contractor shall not at any time assign, sublet his contract or any part thereof to any person or allow such person to become in any way interested therein in any manner what so ever without the prior permission in writing of the Regional Project Director in charge of the work. Any contravention of this condition shall entitle the Authority to rescind the contract and shall also tender the contractor liable for payment to the Authority in respect of any loss or dam age arising out of or ensuing from such recession of the contract. Provided further that where the subletting of the work by the contractor, in any case, is permitted' by the Authority, the contractor shall not, at any time, be absolved of any obligation or responsibility under the contract or any part thereof and shall continue to be responsible for all acts or omission and com missions of the sub contract, his agents, servants or workmen as fully and effectually as if the same were acts of omissions and commissions of the contractor, his agents, servants or workmen, as the case may be.

9.17 CONTRACTOR'S AGENT:

9.17.1 The contractor shall, when he is not personally present at the site of the work invariably place and keep at such site a properly qualified agent, duly authorized and empowered to act on his behalf and to receive on his behalf the orders and instructions required or permitted under the contract to be given to the contractor by the Regional Project Director or his subordinates to supervise the work. All such orders and instructions given to, and all acts done by agents shall be binding on the contractor as if such orders and instructions were given to him or, such acts had been done by him.

9.17.2 Before absenting himself, the contractor shall furnish the name, the designation and the address of the Agent.

9.17.3 Prior to the appointment of such agent, the contractor shall submit to the Regional Project Director the name and other relevant details of the person intended to be appointed as his agent and no appointment shall be made until the Regional Project Director has approved the same and notified his approval in writing to the contractor and whenever the contractor desires to change his agent the same procedure as for the appointment of a new or fresh agent shall be followed.

9.17.4 From the moment the agent so approved and appointed takes charge of the work, he shall be held to be fully authorized and empowered to present and act for and on behalf of the contractor for all or any of the purpose of the contract, and notwithstanding the absence of any formal authority or definite' instructions from the Contractor to the said agent or any defects therein, or the imposition of any restrictions or limitations on the power or authority of such agent by the contractor, nothing whatsoever shall in any way affect, qualify or limit the full authority or power of such agent, or absolve the contractor of his liabilities or obligations under the contract.

9.17.5 The contractor shall forthwith remove from the site and works and not to re – employ without the written permission of the Regional Project Director, obtained in his behalf, any agent whose removal the Regional Project Director have asked for in writing, or any assistant whom he may consider incompetent or is sufficiently qualified or to have been guilty of misconduct or negligence and whose removal the Regional Project Director may have asked f or in writing.

9.18 SUPERVISORY STAFF OF THE CONTRACTOR

9.18.1 The contractor shall not employ any person who was in the service of the Authority or the Government without definite written sanction of the Authority. The staff employed at the site by the contractor shall be the same as he has agreed for in the relevant format included in this tender document. Any change from the same shall have proper written acceptance of the Regional Project Director.

9.18.2 The contractor shall at all times place and keep on the work an adequate number of efficient and competent staff to give necessary directions to his workmen in the execution of the work and to see that the workmen execute the work in a sound and proper manner and shall employ only such supervisors, workmen and laborers in or about the execution of the work, as are careful and skilled in their various trades and callings.

9.18.3 The contractor shall forthwith remove from the work any supervisor, workmen or laborer objected to by the Regional Project Director, and if and whenever so required by the Regional Project Director the contractor shall submit the correct return showing the name of all staff and workmen employed by him or about the work.

9.18.4 If, in the opinion of the Regional Project Director, the contractor is not employing on the work such number of staff and workmen as is reasonably necessary for the, proper completion of the work within the time prescribed he shall forthwith communicate his o pinion in writing to the contractor, and the contractor shall within seven days of the receipt of the said communication, employ such additional staff and labour as may be required by the Regional Project Director and any failure on the part of the contractor to comply with such instructions shall entitle the Authority to rescind the contract.

9.18.5 The contractor shall engage not less than one Engineering Graduate and one Engineering Diploma holder at the work site at his cost and any failure in this regard will be treated as breach of contract and shall entitle the Authority to penalize the contractor/rescind the contract.

9.19 DAMAGES PAYABLE BY THE CONTRACTOR

9.19.1 DAMAGE TO PROPERTY AND PERSON

1. The contractor shall, at his own expenses and to the satisfaction of the Regional project Director, reinstate and make good or be liable for any compensation for any injury, loss or damage occasioned to any property or right whatsoever, including the property and right of the Authority, servants or employees of the Authority, being injury, loss or damage arising out of or in

any way connected with, the execution or purported execution of the contract, and further the contractor shall indemnify the Authority, private person, in respect of any such injury including, any injury resulting in death or disability to person or property, including all claims which may arise under the Workmen's Compensation Act, or under any other law for the time being in force or otherwise.

2. The contractor shall (except if and so far as the specifications otherwise provide) indemnify and keep indemnified the Regional Project Director for all losses and claims for injuries or damages to any person or property whatsoever including surface or other damage to land being or crops being on the site suffered by tenants and occupiers which may arise out or in consequence of the construction and maintenance of the works and against all claim, demands, proceedings, damages, costs charges and expense whatsoever in respect thereof or in relation thereto, provided always that nothing therein contained shall be deemed to render the contractor liable for or in respect of or to indemnify the Authority against any compensation or damages for or with respect to
 - a. The permanent use or occupation of the land by the work or any part thereof (save in respect of damage to crop as aforesaid).
 - b. The right of the authority to construct the work or any part thereof on, over, under in or throughout the land.
 - c. Interference whether temporary or permanent with any right of light, airway or water or other easement or quasi-easement which is the unavoidable result of the construction of the work in accordance with the contract.
 - d. Injuries or damages to person or property resulting from any act or neglect done or committed during the currency of contract by the Authority /Departmental officers, servants or other contractors (not being employed by the contractor) or in respect of any claim demand, proceedings, damage, cost, charges and expenses in respect thereof or in relation thereto.
3. If compensation has to be paid to court attachment or judgment etc. due to damage of person or property, such amount will be recovered from the contractor / tenderer.
4. The contractor shall insure all the employees employed in the work site as per rules against any accidents and further claim. KRWSA will not be responsible for any such accidents/claims of employees of the contractor.

9.19.2 METHOD OF RECOVERY

1. Damages payable by the contractor under the terms of the contract may be deducted by the Regional Project Director from part of his security deposit or from any other sums due, or which may become due to him from the Authority or through revenue recovery proceedings.
2. In every case in which under any clause or clauses of this contract, the contractor shall have rendered himself liable to damages amounting to the whole of his security deposit, the Regional project Director shall have powers to rescind the contract altogether and to have the work completed without further notice, at the contractor's risk or expense as the Agreement Authority/ Regional Project Director may deem best suited to the interest of the Authority and the contractor shall have no claim to compensation for any loss that may accrue from any material he may have collected or engagements he may have entered into, on account of the work and the Regional Project Director shall have powers to deduct whatever amount may be expended on the completion of the work, from any sums that may be due or become due from the Authority to the contractor on account of this or any other work or recover such sums from him and his

assets, movable and immovable under the provision of the Revenue Recovery Act for the time being in force, as if they were arrears of land Revenue or otherwise as the Authority may choose. And in case the contract shall be rescinded under the provision afore said, the contractor shall not be entitled to recover or be paid any sum of any work actually performed under this contract unless and until the Regional Project Director shall have certified the performance of such work and the value thereof and he shall only be entitled to be paid the value so certified.

3. In the event of the Regional Project Director 's putting in force the powers vested on him under the preceding clause, he may, if he so requires it, take possession of all tools, plant, materials and stores or any portion thereof, on the place where the works were to be performed or on other land of the Authority adjoining thereto, paying or allowing for the same in account, at the contract rates, or if not specially provided for therein at current market rates, otherwise the contractor may be required to remove such tools, plant and materials or stores from the premises, and in the event of his failing to do so, the Regional Project Director may remove them at the contractors expense or sell them by auction on account of the contractor. The Regional Project Director may devote all, or such portion as may be requisite, any guarantee or reserve fund or any moneys due to or become due to the contractor for this or any other work to make good, bad or indifferent work, on the part of the contractor in such manner as he may think desirable.
4. If it shall appear to the Regional Project Director or his subordinate in charge of the work, that any work has been executed with unsound imperfect or unskilled workmanship, or with materials of an inferior description, the contractor shall on demand in writing forthwith rectify, relay, remove or reconstruct the same in whole or in part, as the case may require, at his own cost, and in the event of his refusing to do so within a period to be specified by the Regional Project Director or his subordinate or if he shall fail to remove, from the site of the work within a specified period any material or article which is considered by the same officers as unsound or of bad quality or not agreeable to the terms of the contract and to provide immediately suitable materials or articles in lieu of these condemned, then the contractor shall be liable to pay damages at the rate of one percent on the amount of the estimate for every day not exceeding ten days that he fails to comply with the written demand of the Regional project Director or his subordinates. And in the event of non – compliance of the written demand even after the lapse of ten days the contract is liable to be terminated at the risk and cost of the contractor without further notice.
5. All compensations or other sums of money payable by the contractor to the Authority under the terms of this contract with the Authority or under any other contract with the Authority, shall without prejudice to any other mode of recovery, be recoverable from the contractor by way of deduction or payment, out of the sale proceed of a sufficient part of the security deposit held in Government Securities or in National Savings Certificate or out of the interest accrued thereon or out of the said security deposit held in cash or out of any sums which may be due or may subsequently become due, to the contractor from the Authority, on any account what so ever and in the event of the value of his security deposit being reduced by reason of any such deductions the shortage shall be made up by effecting extra recovery from subsequent bills or sales.

9.20 RELICS AND EXCAVATED MATERIALS

- 9.20.1** All gold, silver and other materials of any description and all precious stones, coins, treasures, relics, antiquities and other similar things which shall be found in or upon the site shall be the property of the Government and the contractor shall duly preserve the same to the satisfaction of

the Authority and shall, from time to time, deliver the same to such person or persons as the Authority may appoint to receive the same.

9.20.2 The contractor shall not sell, or otherwise dispose of or remove, any sand, stone, clay, ballast, earth, rock or other substances or materials which may be obtained from any excavation made in or upon the site, or any building or produce standing upon the site at the time of obtaining the delivery or possession thereof and all such substances, materials, buildings and produce shall be and shall continue to be the property of the Authority provided that the contractor may, with the permission of the Regional Project Director use the same for the work at such cost as may be determined by the Regional Project Director.

9.21 REPORTING OF ACCIDENT

The contractor shall be responsible for the safety of all employees or workmen employed or engaged by him on and in connection with the work and shall forthwith report to the Regional project Director or his assistant all cases of serious accidents/injuries to any of them, however caused and whatever occurring on the work and shall make adequate arrangements for rendering all possible aids to the victims of the accidents.

9.22 WORKMEN'S COMPENSATION ACT

In every case in which, by virtue of the provisions of Sub Section (1) of Section 12 of the Workmen's Compensation Act 1923, if the Authority is obliged to pay any compensation to a workman employed by the contractor in the execution of the work, Authority shall recover from the contractor the amount of the compensation so paid and, without prejudice to the rights of the employer under Sub Section (2) of Section 12 of the said Act, the Authority shall be at liberty to recover such amount or any part thereof by deducting it from the security deposit or from any sum due from the Authority to the contractor, whether under these conditions or otherwise. The Authority shall not be bound to contest any claim made against him under Sub Section (1) of Section 12 of the said Act except on the written request of the contractor and upon his giving to the Authority full security for all the costs for which the Authority may become liable in consequence of contesting such claim.

9.23 WAGES TO LABOUR

9.23.1 The contractor shall comply with the provisions of the Minimum Wages Act and the rules made there under in respect of all employees or workmen employed or engaged by him on road construction or in building operations or in stone breaking or stone crushing for the purpose of carrying out the contract.

9.23.2 If, in compliance with the terms of the contract, the contractor supplies any Labour to be used wholly or partly under the direct orders and control of the Authority whether in connection with the work being executed by the contractor or otherwise for purposes of Authority such Labour for the purpose of this clause, be deemed to be persons employed by the contract.

9.23.3 If any money shall, as a result of any claims or applications made under the said Act, be directed to be paid by the Authority, such moneys shall be deemed to be moneys payable to the Authority by the contractor , and on failure of contractor to repay the Authority any moneys as aforesaid within 7 days after the same shall have been demanded, the Authority shall be entitled to recover the same from any money due to the contractor under the contract or any other contract with the Authority.

9.23.4 The Authority shall also be entitled to deduct from any money due to the contractor (whether under the contract or any other contract with the Authority) money paid or payable by the Authority by way of any compensation under the said Act or on account of costs or expenses in

connection with any claims thereto and the decision of the Regional Project Director on any question arising out of the application of this clause shall be final and binding upon the contractor.

9.23.5 In respect of all labour directly or indirectly employed, in works for the performance of the contract as part of this agreement, the contractor shall comply with or caused to be complied with all rules framed by the Authority from time to time for the protection of health and sanitary arrangements for the workers employed by the Kerala Rural Water Supply and Sanitation Agency and its contractor.

9.24 LABOUR RETURNS

Monthly labour returns shall be submitted by the contractor to Regional Project Director in the proper forms so as to reach him not later than the first of every month. In addition to the above, the contractor shall also maintain daily and weekly returns of labour employed by him and these shall be made available for verification by the officers of Kerala Rural Water Supply and Sanitation Agency as and when called for.

9.25 CONTRACT DOCUMENTS AND MATTERS TO BE TREATED AS CONFIDENTIAL

All documents correspondences, decisions and orders concerning the contract shall be considered as confidential and / or restricted in nature by the contractors and he shall not divulge or allow access to them by any unauthorized person.

9.26 MATERIALS TO BE SUPPLIED BY THE AUTHORITY

It shall be the responsibility of the contractor to arrange for materials and the Authority shall not issue any material to the contractor.

9.27 CONTRACTOR'S RESPONSIBILITY FOR STORES

The materials such as Cement, MS Rods, tor steel and other materials including pipes and specials required for the work shall be procured by the contractor and the amount quoted should be inclusive of the cost of cement, steel and all other materials. The cement supplied for use shall be as per ISS 269/1976 and steel as per ISS 1786/1985 with latest amendments, if any. The materials should bear the relevant ISI/ISO certification marks. Before using any material for the work, the contractor, at his own cost, shall submit to the Regional Project Director for his approval such samples of material as are proposed to be used. The materials shall strictly conform to the specifications approved by the Authority. Notwithstanding anything contained in this clause, the contractor shall be held fully responsible for the quality and soundness of all the materials and machinery that are supplied by him for the execution of the work and completion of the project and the Regional Project Director's approval shall not in any way absolve him of his responsibility in this matter. The standard tests as per ISS to ensure the quality of cement, steel and other construction materials shall be got done by the contractor at their cost as per the direction of the officers of Kerala Rural Water Supply and Sanitation Agency to ascertain the quality. The Authority reserves the right to super check the results. If the materials supplied are found to be not passing the tests, the same shall be rejected by the Regional Project Director and the contractor shall be bound to dismantle and remove such constructions already made using such sub standard quality materials if found during the erection of the work and the contractor shall be fully responsible and liable for such losses to the Kerala Rural Water Supply and Sanitation Agency.

9.28 MATERIALS AND PLANT AT WORK SITE

All materials and plants brought by the contractor in or upon the site or on the land occupied by the contractor in connection with the work and intended to be used for the execution thereof shall not be removed from the site of work without the permission of the Regional Project Director.

9.29 GENERAL

All other conditions shall be as in force in the Kerala Rural Water Supply and Sanitation Agency, if it is found relevant to explain any clause of this N.I.T. Otherwise the conditions are strictly independent.

Regional Project Director

KERALA RURAL WATER SUPPLY AND SANITATION AGENCY

10. GENERAL TECHNICAL SPECIFICATIONS

10.1 GENERAL

10.1.1 Generally, the specifications of all materials and work pertaining to this contract shall be governed by the relevant Indian Standards and by MDSS. In the absence of Indian Standards, the British Standard Specifications shall be followed. The specifications furnished hereunder are only to enlighten the tenderer on the requirements of Kerala Rural Water Supply and Sanitation Agency and are not intended to be against any other specifications stipulated by BIS or other standards and common practices widely adopted in the country at present. In case of a doubt regarding the specifications, the Engineer in charge will clear the doubts and give final decision based on the written request of the contractor. The decisions intimated in writing shall be binding on the contract work.

10.1.2 The successful completion of this contract calls for site surveys, investigation, planning, hydraulic and structural design of the components, assessment of capacity/standard of mechanical, electromechanical and electrical items to be procured, preparation of procurement schedule, preparation of implementation schedule etc. The tenderer shall see that he always sticks on to conservative designs based on time tested and well accepted practices as per the guidelines and norms prescribed by BIS, CPHEEO or such other institutions.

10.1.3. REPORTS, DESIGNS AND DRAWINGS

1. Reports, designs and drawings etc. connected with the work shall be furnished by the contractor for approval, minimum in triplicate copies or as called for by the Engineer in charge.
2. Contractor shall prepare and submit to the approving authority seven additional copies of the approved drawings immediately on receipt of approval for transmission to various field offices.
3. On completion of approval of all items connected with the project, the contractor shall prepare three copies of bound volumes of the approved documents and furnish to the approving authority. The preparation and binding of this document should be in such a manner that during the long period of future reference and recorded life, it shall not get disintegrated nor legibility lost.

10.1.4 ECO -FRIENDLY SYSTEM OFFER

The system offered and as completed shall be environment friendly and shall not affect /alter the environment beyond any permissible limits stipulated by concerned institutions.

10.1.5 MAN MADE STRUCTURES, OTHER UTILITIES - AFFECTING THE WORK

1. When the works under this contract are executed situations may arise when the works are affected by other manmade structures either in service or abandoned. It is also likely that other utility services installed by various Government bodies are affected by the works under this contract. It shall be the duty of the contractor to ensure whether adequate sanction has been obtained from the authority concerned for the work with the help of Kerala Rural Water Supply and Sanitation Agency before the works of such affected portions are undertaken. Any damage caused to any of the manmade structure or any of the utility services will have to be made good by the contractor at his cost. The contractor has to restore the original position if he has to demolish any structure like culverts, compound walls etc during the course of work at his own cost.

2. However, restoration of PWD roads is exception to this. The KRWSA will bear the cost of such restoration of roads provided damaging of the road was essential for the execution of works under this contract. However the contractor should make the road trafficable as far as possible to the maximum extent after the work of laying pipes as per the direction of Engineer in charge.

10.2 EARTHWORK EXCAVATION

Earthwork excavation means earthwork in all classes of soils / rocks whenever removal shall be not by blasting. Earthwork excavation shall be done with adequate care so that underground service lines or adjacent structures are not damaged and appropriate protective measures such as shoring / strutting / sheet piling etc. are adopted for such items as required and approved by the Engineer in charge of the work. The width of trench should be as per the requirement and as per standard data book and a minimum cover above crown of pipe should be maintained as per clause 10.13. If the width of trench exceeds the minimum requirement as noted above, due to faulty workmanship /protection/shoring etc. the additional payment for the extra damaged road width payable to PWD/NH local bodies etc. shall be recovered from the contractor's bill. Excavation by blasting shall be got done only through persons holding valid license for use of explosive material and for blasting purpose. Further all rules prescribed by the Inspectorate of Explosives shall be strictly adhered to whenever blasting is resorted to. Blasted material like the excavated rock shall be the property of Government of Kerala. Disposal of the materials up to a distance of 10 km from the site as well as cartage of excavated material during excavation and back filling up to a maximum distance of 5.0 km will have to be done whenever essential by the contractor at no extra cost.

10.3 FILLING / BACK FILLING

Filling / back filling shall be done only with approved materials. It shall be compacted to get the following results. The density of the filled materials at different depths shall not be less than 95% of the natural field density in case of back fill and shall not be less than 95% of maximum dry density obtained in proctor compaction test or such other approved tests whenever filling is done to get the desired formation ground level. It shall be ensured that the density thus obtained under compaction is uniform at all depths of the fill. The contractor is bound to bear the cost of any test conducted to ascertain the above condition in case of doubt. The filling/backfilling done along PWD roads or such properties owned by other department/institutions, the same shall be further governed by specifications of such owner.

10.4 SHORING

Shoring shall be essential in excavation in all classes of soils whenever depth of excavation exceeds 1.50m and labourers have to work in trenches or close to edges of trenches as per the direction of Engineer in Charge. In ordinary soils and loose soils, shoring shall be done for trenches of shallower depths also considering the chances of collapse of sides. Shoring shall be done as approved/directed by the Engineer in charge of work.

10.5 FENCING

Fencing shall be done in the approved manner along the side of pipeline trenches on roads or other places for preventing accidents on both sides, if required in the opinion of the Engineer in charge.

10.6 FORMATION OF ROADS

Formation of roads shall be done as per IRC rules and regulations for the use of desired class of vehicles mentioned in the scope of the work. Whenever road formation comes in the scope of the work, it shall be

understood that all cross drainage work, side drain works, radius of curvature and super -elevation etc. are included in the scope.

10.7 RUBBLE MASONRY

Rubble masonry works using approved quality blasted rubble either as random rubble masonry or coursed rubble masonry shall be permitted. Minimum width of the random rubble masonry shall not be less than 450mm in any case. Only cement mortar 1:6 or richer shall be used for such works. Mixing by weight at the above ratio for mortar shall be permitted only when the fine aggregate is in dry condition. Exposed surfaces of rubble masonry shall be pointed using 1:3 cement mortar to have a pleasing appearance provided it is left un-plastered with cement mortar.

10.8 BRICK WORK

Brick masonry using wire cut bricks / first class country burned bricks having a minimum crushing strength of 35 Kg / cm satisfying other tests specified by BIS and least dimensions not less than 70mm in any case shall be permitted. Brick masonry works shall be of minimum 200 mm width, constructed in English bond with cement mortar 1: 6 or richer and plastered with cement mortar 1: 4 or richer in all cases. However, in each case of parapets or other dwarf walls of height less than 700 mm, thickness of masonry can be reduced from 200mm provided pilasters of minimum 200 x 200 mm are constructed monolithic with such walls at a center to center spacing of maximum 3000mm.

10.9 PLAIN AND REINFORCED CONCRETE

10.9.1 DESIGN ASSUMPTIONS

IS 3370 Code of Practice for concrete structure for storage of liquids

Part I : 1965 (or latest edition) General requirements

Part II : 1965(or latest edition) Reinforced concrete structures.

Part IV : 1967(or latest edition) Design tables

IS 2502/1963 (or latest edition) Code of practice for bending and fixing of bars for concrete reinforcement. All RC C/Steel structures shall be based on the relevant IS Codes. Strict adherence must be established to accepted codes of Practice relating to design. Minimum cover to reinforcement of RCC work shall be provided as per IS 456 -2000 (or latest edition). The effect of seismic forces shall be taken into account in the design as per the relevant code of practice.

10.9.2 CEMENT

The contractor will have to procure the cement for the work. The cement used in the work of plant or water front structures should be sulphate resistant - Portland cement of reputed companies having ISI mark. The KRWSA will have the option of rejecting the cement procured by the contractor and ask for replacements, in case of any doubt on quality and age of cement supplied at site. Random /grab sampling and test of the cement will be got done as per the norms of KRWSA.

10.9.3 REINFORCING STEEL

Only Corrosion Resistant Steel (CRS) is to be used for the steel structures. The contractor has to procure all the steel required for the work. The steel so procured should be from reputed companies like SAIL, TISCO etc. and the KRWSA will have the option to select the brand and to ask for replacement, if the material is found not having adequate quality. The MS/T OR rods supplied for the work shall be cleaned and scrapped to be free of scales rust etc., before placing in forms for R.C.C work.

10.9.4 AGGREGATES

The coarse and fine aggregates shall comply with IS 388 -1980 or latest edition and may be used after sufficient tests have been carried out and approved by the Regional Project Director. All aggregates shall be stored on hard impervious surface to ensure exclusion of all foreign materials.

10.9.5 WATER

The water for mix shall be clean and free from harmful matter as per IS standards and taken from a source approved by the Regional Project Director.

10.9.6 ADMIXTURES

Only where a beneficial effect is produced shall any admixture to be used and that too after tests have been carried out to convince the Regional Project Director that no harmful effect will be produced by the use of such admixture and after approved by the Regional Project Director. Time tested admixtures shall be permitted to be used for concrete based on testimonial of performance to improve the quality of concrete with respect to its strength, water tightness or for other specified purposes as required for the work.

10.9.7 MIXING

The grade of concrete shall be as per IS 456:2000 or its latest revision. All water retaining or water front structures and machine foundations shall be made in RCC mixes not leaner than M25. The mixing time shall be between 2 to 4 minutes. The contractor should produce mix design for all grades of concrete to be used for the work and get approval from the Regional Project Director before commencement of concreting.

10.9.8 CONCRETING

The concrete mix shall be in specified proportions satisfying the maximum aggregate size/water cement ratio and required cube strength and workability. Such concrete must be adequately vibrated to form solid mass without voids. External vibration by the use of pneumatic hammers shall be deemed adequate except for thin sections.

10.9.9 TRANSPORTATION AND PLACING

Transportation and deposition of concrete mix shall be done rapidly and accurately with minimum re-handling. The mix must not be dropped from such a height as may cause segregation and air entrapment. When the mix is placed in position, no further water shall be added to provide easier workability. No concrete mix shall be used for the work if it has been left for a period exceeding its initial setting time before deposited and vibrated into its final position in the member. Sufficient number of cubes must be made for testing as per the relevant BIS code specifications. It shall be tested as per the specification and a complete register of entries shall be maintained by the contractor. It shall be brought to the notice of the Engineer in charge as and when directed by the departmental officer. The cost of all such testing shall be borne by the contractor.

10.9.10 CONSTRUCTION JOINTS

Construction joints shall be avoided wherever possible, and if found necessary, should be of such form to encounter direct compression. A stepped joint being preferred in such a case.

10.9.11 CURING

Curing shall be done as per relevant provisions in the IS code to allow the concrete attain strength through normal hydration and to avoid excessive shrinkage or harmful effect to the member. The method adopted shall be effective and any special method used must be approved by the Regional project Director.

10.9.12 REMOVAL OF FORM WORK

Removal of form work shall be done as per the provisions in the BIS and as per direction of the Regional project Director and in such a manner that no damage is caused to the deflection to minimum deflection, when unsupported and as per the direction of the Regional project Director.

10.10 DOORS, WINDOWS AND VENTILATORS

10.10.1 Wooden doors and windows and ventilators shall be made as per the approved DATA only and the size of doors, frames, shutters etc shall be not less than the sizes specified in MDSS, PWD standard data book etc. All parts of the door shutter or frame shall contain only hard wood seasoned. Wooden doors and shutters shall be provided for interior doors of office room s/private rooms etc.

10.10.2 Steel doors, windows and ventilators shall strictly conform to the specifications of BIS. Steel doors, windows and ventilators shall be permitted only for locations where aggressive conditions damaging the doors do not exist and when appearance of the same do not adversely affect the pleasing appearance of the main view and aesthetic condition of the structure. Steel windows and ventilators shall have crossbars for preventing through passage of solid materials of least dimension of 120mm in open position provided in aesthetically pleasing manner.

10.10.3 For areas directly facing the main views of the structure, aluminium doors, windows and ventilators shall be provided for improving the front view of the structure so far as there are no aggressive surroundings damaging the life or the pleasing appearance. All aluminium Sections shall be anodized as per ISS.

10.10.4 PVC doors of specifications conforming to those of BIS or of better quality may be used for water closets, bathrooms or other locations where splashing of water may affect the life of other type of doors.

10.11 PLASTERING OF EXPOSED SURFACES

All exposed concrete surfaces shall be plastered with cement mortar 1:4 or richer mixes. Exposed surface means exposed to air or water or any other gaseous or liquid medium. Surfaces of concrete structures other than water retaining structures can be permitted to be left unflustered under the following conditions:

- a) The surface left unflustered is perfectly even without markings of form work or undulations or unevenness greater than 0.5mm.
- b) The surface texture is perfectly uniform and the appearance is pleasing.

10.12 TESTING OF WATER RETAINING STRUCTURES

All water retaining structures shall be filled with water and tested for water tightness before the commencement of plastering. For water retaining structures the requirement of the test shall be deemed to be satisfied if the external faces show no sign of leakage and remain apparently say, over a period of observation of seven days after filling up to maximum water level and allowing seven days period for absorption, if the structure does not satisfy the condition of the test and the daily drop of water level is decreasing, the period of test may be extended for a further period of seven days, and, if the specified condition of the tests are satisfied, the structure shall be considered to have withstood the test.

10.13 PIPES AND PIPE LAYING

The material and class of pipes used for the contract shall be as specified in the Scope of Works or tender drawings in the "Scope of Works." In case the pipes have not been specified for an item of work, the contractor shall put forth his proposal in accordance with CPHEEO guidelines and rules of BIS and get prior approval from the Engineer in charge. Pipe laid underground shall have a minimum earth cover of 1.00 m above its crown and in such a manner that the bedding angle is not less than 120, and the loads of pipe carrying liquid and the overlaying substance transmitted to the soil uniformly through the entire barrel of the pipe. For AC pipes, such cover above the crown shall be 1.20m at the alignment over which heavy traffic is expected. Whenever special fill materials are required to achieve this goal, sandy soil / river sand shall be provided at no extra cost by the contractor and on the approval obtained from the Engineer in charge. Wherever the cover for the pipe is less than 1.00 m, approved protective measures shall be taken and necessary works executed to see that the pipes are not damaged due to any external loads. In cases where the pipes are laid at ground level, adequate protective works ensuring the safety, serviceability and durability of pipes as approved by the Engineer in charge shall be undertaken as part of the contract. When pipes are over the ground; the support shall be designed and spaced in such a manner that the total stress induced in the pipe shell material at any section does not exceed the safe permissible values. In no case, the socket or spigot shall be allowed to transmit weight of other parts. For design purposes, minimum vertical and horizontal loads of 150 kg/m shall be assumed to act on the pipeline over and above the other known loads. Pipes rising vertically or at angles greater than 20° to the horizontal and which cannot carry / transmit the load through the shell of the barrel uniformly shall be only of flanged pipes. These pipes shall be supported appropriately both vertically and horizontally to ensure the positional fixity in the desired axis in such a manner that no part of shell of the barrel is subjected to stresses above safe permissible values.

During lying of pipe line, the open end of pipes shall be kept closed with dummies, blank flanges or end plugs at closure/suspension of work to prevent entry of soil, or, other unwanted material inside the pipe. No pipe shall be left open for period exceeding 30 minutes even in the presence of responsible personnel. Lying of pipes should be done in accordance with relevant IS codes with its latest amendment and revisions.

GENERAL

This specification covers supply, testing and delivery of **DI, GI & PVC pipes** of required length. The pipes are to be designed to withstand the effect of internal water pressure, external loads and surge pressure.

The intending tenderers should produce an undertaking with the manufacturers of pipes and specials regarding the capability to cope up with the contract, specification /quality etc. and submit it along with the tender.

Quality of materials and manufacture

Quality of materials and manufacture of pipes and specials should confirm to the relevant BIS or ISO Specification and shall have the respective certification marks of the Standard organization

Marking on Pipes

Each pipe shall be legibly marked with the following details :

- i. Manufacturer's name or trade mark
- ii. Nominal size (as per relevant ISS) Pipe description - class and grade.
- iii. Relevant ISI/ISO Certification markings

All dimensions and specifications shall strictly adhere to the relevant I.S codes/ISO Standards and as amended up to date.

Testing of pipes

The field test pressure to be applied shall not be less than the greatest of the following.

1. 1.5 times the maximum sustained operating pressure
2. 1.5 times the maximum pipeline static pressure
3. Sum of maximum sustained operating pressure and maximum surge pressure
4. Sum of the maximum static pressure and surge pressure subject to a maximum for any pipe and fittings incorporated.

SURGE PRESSURE:

The maximum surge pressure should be analyzed based on the data supplemented and in no case the sum of maximum operating pressure and the calculated surge pressure should exceed the allowable field hydrostatic test pressure. Computer model analysis shall be got done for the pumping line right from the pump's delivery point up to the exit point of water by any reputed institutions approved by the Authority and detailed reports of the institutions shall be furnished to the Authority.

HYDRAULIC DESIGN OF PIPE LINES

Hydraulic design of pipelines etc. where design based on Hazen William's formula as recommended by the Water Supply Manual is used, selection of the formula shall be done to get the higher design values.

Design of fittings

The following information shall be clearly marked on each fitting.

- (1) Nominal size and weight / wall thickness
- (2) Classification based on pressure
- (3) Manufacture's name.

10.14 SUPPLY OF MATERIALS

10.14.1 SUPPLY OF PIPES

All pipes as per the scope of the work supplied should be factory tested and test certificate as per relevant specification/latest code of practice should be produced along with the pipe supplied. The testing of pipes and the authentication of test certificate should be done by an approved third party inspection agency agreeable to KRWSA and witnessed by the technically qualified officers of KRWSA, if the contract value exceeds Rs.100 lakhs and by a Departmental Officer deputed by KRWSA if the contract value is less than Rs. 100 lakhs. In case the pipes are imported from abroad, samples for metallurgical and mechanical tests shall be taken from pipes selected at random and the final acceptance of the pipes will be based on the results of such tests conducted at any of the reputed laboratories.

10.14.2 SUPPLY OF M.S PIPES: LINING

MS pipes are to be lined at the contractors own arranged site located in or around the project area in the presence of Authority Officers. Shop lined pipes will not be accepted. Lining should conform to IS 1916 - 1989 or its latest edition. Minimum lining thickness, cement content, Characteristic compressive strength etc. should be as per the IS specifications. River sand used should be properly

cleaned and sieved and only aggregates conforming to IS 383 (or latest edition) and with required uniformity coefficient shall be used.

(a) INSIDE LINING

Clean the surface of the pipe for removing rust and other unwanted matter by sand blasting or other approved methods. Mound the pipe on the spinning machine and get the cement mortar of 1:2 applied and compacted uniformly by centrifugal action over the entire area. The line pipes shall have a smooth surface inside it and shall be free from rakes and patches after curing. At joints the pipes should be given lining of minimum thickness as per IS specification with CC 1:1 using wire mesh of approved gauge.

(b) OUT SIDE LINING WITH CEMENT MORTAR:

The surface shall be cleaned as in (a) above. A wire mesh of 50 x 50 x 3 mm or nearest size approved by the Engineer in charge shall be wound over the pipe keeping a uniform gap of 13mm from surface of pipe and fix the same by use of spacers, welding etc. in the approved manner. Cement mortar 1:3 shall be applied by gunning or other approved techniques to attain minimum thickness as per IS specifications and cured appropriately. The surface so finished shall have a fairly uniform finish and shall be free from cracks and patches.

(c) OUTSIDE LINING WITH COALTAR etc.

Outside lining with hot applied coal tar / as phaltic enamel reinforced with fiber-glass fabric yarn as per IS 10221 -1982 or its latest edition or relevant American / British standards shall be provided based upon the observed soil receptivity in Ohms -cm.

(d) ALL TENDERERS SHOULD QUOTE FOR INSIDE LINING WITH CEMENT MORTAR

Tenderers who have quoted only for lining with cement mortar inside and outside lining with hot applied coal tar (alternate offer) will not be considered.

(e) After inside lining, pipes should be cured in a curing pond for a minimum period of 7 days or as provided in the latest IS 5822. Minimum cover of pipe as per IS / Manual shall be provided. The detailed specification of site welding of joints should be furnished by the contractor with relevant IS / British / American standards. The welding electrodes used should also conform to relevant IS / British /American Standards.

10.14.3 SUPPLY OF SPECIALS

The supplied specials should be tested as per relevant specification and latest code of practice. The certificate of testing should be authenticated by the technically qualified officers of KRWSA or a third party agreeable to KRWSA.

10.14.4.SUPPLY OF EQUIPMENTS

The works to be executed under this contract shall call for procurement of a number of mechanical items and equipments. The contract or shall procure any equipment / item only after the Authority has approved the manufacturer of the same. Any item / equipment procured and used shall, as far as possible bear certification marks of BIS, BSS or such other standard institutions of international repute and shall be brand -new only. Further care shall be taken that any part / component of such equipment, which require periodic replacement, shall be readily available in the market. Equipments requiring periodic replacement of nonstandard, unpopular or odd items shall not be procured or used for

the fulfillment of this contract. Equipments requiring periodic maintenance shall be identified and a preventive maintenance schedule prepared for such equipments and handed over to the Authority.

10.14.5 ELECTRICAL INSTALLATIONS:

All electrical installations shall be done as per the IE rules and with the concurrence of the Electrical Inspectorate and /or Kerala State Electricity Board. All electrical works shall be done only through approved / licensed persons having qualification, experience and expertise to do the work. It shall be the contractor's sole responsibility to get any clearance from the Electrical Inspectorate.

10.14.6 ELECTRICAL AND ELECTRO - MECHANICAL ITEMS

All electrical and electromechanical items shall be procured from the manufactures approved by the Authority. Any item procured shall bear certification marks of BIS / BSS or another institution of international repute. For any equipment / system requiring periodic maintenance, preventive maintenance schedule shall be prepared and handed over to the Authority as part of fulfillment of this contract.

10.14.7 VALVES

- a. Valves shall be as per IS Specification. Valves shall be double -flanged valves unless specifically permitted by the Engineer in charge. It is permitted to use valves of small diameter than the pipe diameter where it is used provided the valve diameter is not less than 67% of the pipe diameter and approved tapers are provided on both sides to ensure that the changes in the cross sectional area is attained gradually. Valves shall have hand wheel except where provisions of hand wheel shall hinder some other specifications requirements. Valves of diameter 400 mm and above shall be geared / butterfly valves. Valves shall be provided with an appropriate seating so that weight is not transmitted to the adjacent pipe body. Anchoring of pipes at bends or such other locations shall be done in such a manner that the joints of the bend with the straight pipes are not embedded in concrete and easy working of the joints is possible. Scour valves shall be as per the standard specification.
- b. Zero velocity valves / pressure relief valves / surge arrestors etc. shall be used wherever necessary for ensuring the safety of the pipelines. The tenderer should do the water hammer analysis of pumping main and provide appropriate water hammer devices. The system and location proposed should be specifically mentioned in technical bid. The provision of such installations shall be subject to the condition that (i) the hydraulic design of these item are approved by KRWSA (ii) the particular brand valve proposed to be used is a time tested one as per the testimonials furnished, (iii) the guarantee card of the system issued by the manufacturer is handed over to the Engineer in charge (iv) such guarantee issued by the manufacturer / tenderer is valid for a period of not less than 5 years of service and (v) the terms and conditions of the guarantee are accepted to KRWSA / Engineer in charge. Fabricated pipes and specials shall be permitted to be used, provided (i) they shall have definite advantages at the particular place proposed, (ii) they satisfy all design requirements for the efficient and long lasting performance of both hydraulic and other functions and (iii) fabrication shall be attained by the seamless continuous welding.

10.14.8 AIR VALVES

Suitable air valves shall be as per standard specifications conforming to relevant G& K catalogue. Air valves shall be invariably provided at essential locations inside a valve chamber and all Air valve shall be supported with same size of control valve below it. For more details in scope of work may be referred.

10.14.9 BENDS & SPECIALS

Bends may be in horizontal plane, vertical plane or in both planes and at angles varying from 11 1/4 ° to 90°. Care must be taken to avoid 90° bends as far as possible and in case it becomes inevitable, permission for the same must be obtained from the Engineer in charge, before laying of pipeline at that section. Bends and specials shall be procured from manufacturers whose products are time tested and have the approval of BIS. The name of manufacturer/or registered trademark and hydraulic proof test shall be marked on all such specials/fittings. As a special case, non-standard MS fabricated bends/specials will be permitted according to site conditions for non -standard bends with the approval of the Engineer in-charge of the work.

10.14.10 CAST IRON MANHOLE COVERS AND FRAMES

The basic requirements of the manhole covers to be used shall be of Heavy Duty grade and Square shape for water supply and circular for drainage work. The manhole covers shall be that manufactured from appropriate grade of cast iron, which shall not be inferior to FE 150 conforming to IS 210 (1978) or latest edition. The manufacture and workmanship shall conform to clause 5 of IS 1726 -1991, IS 210 -1978 & IS 4905 -1968 or their latest versions. Suitable locking devices including that with a Galvanized chain and lock or any such foolproof devices as approved by the Engineer before the supply and erection, the manhole cover/frame shall be provided. The minimum dimension of the manhole cover shall not be less than 60 cm and shall be coated with approved quality of materials as per IS 1726-1991. Each manhole cover and frame shall have embossed on them an identification mark i.e., the mark "KRWSA" to denote Kerala Rural Water Supply and Sanitation Agency together with the manufacture's name /trade mark.

10.14.11 MECHANICAL EQUIPMENT

The mechanical equipment to be installed in intake structures are as noted below:

(i) Sluice Gates

Sluice gates on the water front side of the intake structure at minimum 3 levels so as to draw the raw water from the surface of river during flood, normal and drought seasons. The sluice gates must have facility to operate from the deck slab of the pump house and necessary gear and wheel arrangements must be provided. The opening in the intake structure (the sluice gate) must be provided with cast iron gratings so that the solid or floating material will not enter inside the intake. Such grating or screens shall be easily cleanable of the debris adhering to them.

(ii) Float & Scale Type Water Level Indicator

Water level indicator of float and scale type fabricated with corrosion resistant material approved by the Engineer in Charge must be provided in the Intake well. The location of the indicator and its design etc. must have the approval of the Engineer before its fabrication / installation. The details must be furnished before the Engineer as a submittal with detailed drawings and specification of construction. The float shall be of Copper, Brass or other corrosion resistant material approved by the Engineer, floats shall have appropriate guide for vertical movement, which shall facilitate easy vertical sliding. The guides shall be corrosion resistant material and fixed in such a manner that the floats in case of nay repair, can be removed and kept back in position without disturbing the guides or easy and quick dismantling and refitting is possible.

(iii) Over head gantry crane

The pump house shall be equipped with gantry cranes of appropriate capacity and as per Volume II (scope of work). The gantry crane with pulley block shall have sufficient freedom of movement so that

the entire pump house area can be covered by it. The design and other particulars of the gantry crane must be furnished to the Engineer in charge as a submittal before its procurement and got approved by him.

(iv) Pumps and Motors

The pumps and motors supplied and installed at intake structures and at any pumping stations of the project shall be of reputed make. The design of pump set shall be in such a way that energy consumption during the starting and operating conditions are minimum. Pumps shall have optimal efficiency for the specified / desired discharge as per tender throughout the design life of pump set. The selection of number of pump sets shall be made in such a way that at least 50% stand by is available at any time if the number of pump sets required at each station is not otherwise specified. In case of more than one pump working in combination, either in parallel or series, the different working conditions shall be separately studied and the best energy – economy condition shall be selected. The analysis on operation conditions, the design and the performance characteristics of the pump sets shall be furnished to the Engineer in Charge as a submittal and his prior approval of the same is essential before the actual procurement and installation. In case the tenderer is not the manufacturer of a particular item, he shall disclose the manufacturer of each and every item he proposes to procure for the project. In every such case, he shall present a list of not more than two manufacturers from whom he is planning to procure the items in the order of preference. For preventive maintenance of the pumps, motors and switch gears, consumable spares for the next two years after the completion and commissioning of the work shall be provided by the contractor. The contractor shall also furnish the list of vendors from whom such spares can be procured in future.

(v) Motors, Gears etc.

Motors, gears or such other equipments having constantly moving parts while in service, if installed out door, shall invariably be kept only in metallic boxes / other protective enclosures to protect the equipment from intense sun light, rain and dust. Such items should be quite durable and free from deterioration due to environmental conditions.

(vi) Electrical Panel Boards & Switch gears

It shall be the responsibility of the contractor to supply and install suitably designed electrical panel boards, which shall have necessary provision for taking the power supply from KSEB. All such panel boards shall satisfy and comply with the rules and regulations of the Electrical Inspectorate. The contractor shall carry out all such electrical works through a licensed electrical contractor as per the requirements of I E rules. The design and details of the electrical system at each station together with the specifications of the proposed panel board, circuit breakers, fuse units etc, shall be submitted to the Engineer in charge for his approval, before actual commencement of work and submission to the Electrical Inspectorate. All such items shall be of reputed make and the manufacturer /supplier of each item shall be specified in the submittal along with all other relevant details. The panel boards shall be painted with anticorrosive epoxy paint of approved colour and each installations shall be suitably indicated with name plated on the panel boards. The electrical panels, motors etc. shall be suitably indicated with name plates on the panel boards. The electrical panels, motors etc. shall be suitably indicated with name plates on the panel boards earthed as per IE rules. It shall also be the duty of the contractor to obtain necessary clearance and approval of the electrical inspectorate in all the electrical and electro-mechanical equipments provided for the project as a part of this contract. Instances may occur when it may become necessary for providing transformers for drawing power from KSEB and in all such cases, the supply and erection of transformers, yard structures, switchgears and panel boards shall have to be done as a part of this contract as per IE Rules and Regulations. The contractor

shall fully envisage these things and shall have to execute all such works through licensed personnel and obtain the clearance of Electrical Inspectorate for the proper commissioning and functioning of the system.

(vii) Spares and Consumables

The contractor shall supply the following while handing over the system at the end of one year maintenance period.

- a) Disinfecting agent for a period of one month use.
- b) Chemicals or other similar daily consumable for three month use.
- c) Reagents for the Laboratory for three months.
- d) Spare pipes and fittings etc.
 - For CI/DI/PVC/HDPE pipes the quantity spares to be supplied are,

Pipes up to 300mm diameter	- 3%
Pipes of diameter 300mm and above	- 2%
 - Standard specials – The estimate sanctioning Authority can fix the minimum requirement of specials as per site conditions subject to a maximum of 3% of the cost of specials
 - For MS pipes, no provision for the purpose of the maintenance needs to be included.
- e) Two sets of essential tools that will be required for maintenance and urgent repair works except lifting tools as pulley blocks.

10.15 VALVE CHAMBERS

Valve chambers shall be constructed as per the dimensions provided on the Scope of Work. The construction shall be done only as per the drawing approved by the Engineer in charge. The material used for construction shall be best quality wire cut bricks and both sides plastered / RR with inside plastering / RCC depending upon the design load conditions, availability of space environmental impacts etc. Underground valve chambers along motor able roads shall be of RCC. The design of the valve chamber including that of the cover slab indicating the location, size and class of the manhole cover etc. must be furnished to the Regional Project Director before the actual construction, and, his approval must be received before the commencement of the work at site.

10.16 ANCHOR BLOCKS

All the bends in pipelines (from 11 1/4) shall be provided with suitably designed Anchor blocks. The design of Anchor blocks shall be prepared as per the Water Supply Manual and relevant I.S. Codes and got approved by the Engineer in charge before execution.

10.17 DISCHARGE OF EFFLUENT

Discharging any effluent which may either be a by product of the system or waste from the system, as a result of trial run or otherwise, shall be done carefully not inviting opposition / resistance / objection from any corner. If such discharge requires any form of treatment or any type of civil or other structures for the preservation of original environment conditions, the tenderer shall include such works also in his of forever though such a work has not been envisaged in this document.

10.18 ARCHITECTURAL FEATURE

Architectural features of the structures constructed shall be pleasing, attractive and matching to the site conditions. Selection of colour combinations, ornamental works, materials used for such ornamental works etc. shall be done bearing in mind the following properties as (1) fading phenomenon, (2) resistance to severe climatic conditions (3) strength to withstand unexpected forces that may act on the material / member etc.

10.19 NON DESTRUCTIVE TEST FOR STRENGTH:

Any constructed structure or erected equipment shall be subject to a non destructive test to ensure or certify about its capacity to yield the desired service if required by the Engineer in charge. Such tests shall be the ones specified by the ISS / BSS / CPHE EO Manuals or a more severe test. An equipment / component shall be deemed to have satisfactorily passed such a test only if the Engineer in Charge of the works is satisfied on the performance under test conditions.

10.20 TRAINING TO AUTHORITY STAFF

The Engineer in charge will furnish a list containing the names and designations of the various staff to whom the training in the operation, maintenance and attending to emergent situations are to be given. When the contractor is satisfied that sufficient training both in theoretical and practical aspects have been imparted to the staff thus deputed, shall issue a certificate in that respect which shall be forwarded to the Engineer in Charge. The training shall preferably be in the place of the project work. However, if requested, the contractor shall be permitted to give part of the training to the Authority staff at his place of choice after due consideration of all aspects.

10.21 If any of the conditions above are in contradiction to any of the clauses in the scope of Work, the clause/conditions of the Scope of Work shall prevail

10.22 Contractors/Firms shall not appoint/employ directly/indirectly the retired employees of Kerala Rural Water Supply and Sanitation Agency within 3 years of their retirement/Voluntary retirement/ contract termination.

Regional Project Director

KERALA RURAL WATER SUPPLY AND SANITATION AGENCY

FORMAT Q1

**PARTICULARS OF MAJOR WORKS COMMENCED AND COMPLETED BY
THE TENDERER AND HIS PARTNERS / ASSOCIATES DURING THE PAST TEN
YEARS INCLUDING WORKS IN KRWSA**

USE SEPARATE PHOTOCOPIED SHEET FOR EACH PARTNER

Sl. No	Full particulars of works similar to the present tender	Contract amount as per award	Date of agreement	Actual amount on completion	Original completion Time (as per agreement)	Actual completion time (Certificate or completion from the authority concerned showing relevant details to be enclosed)	Name and address of the authority for whom the work was carried out	The exact nature of association of the tenderer with the contractor who carried out the work
1	2	3	4	5	6	7	8	9

Name of Tenderer :

TENDERER

REGIONAL PROJECT DIRECTOR

KERALA RURAL WATER SUPPLY AND SANITATION AGENCY

FORMAT Q 2

PARTICULARS OF MAJOR WORKS IN HAND WITH THE TENDERER AND HIS PARTNERS /ASSOCIATES /CONSULTANTS INCLUDING WORKS IN KRWSA

USE SEPARATE PHOTOCOPIED SHEET FOR EACH PARTNER

Sl No	Name of Work	Accepted PAC (Rs. in lakhs) and date of agrt.	Date of completion as per agrt	Anticipated date of completion	Cost of completed work (Rs. in lakhs)	Cost of remaining work (Rs. in lakhs)	Name and address of the authority for whom the work is done	Other information if any
1	2	3	4	5	6	7	8	9

Name of Tenderer :

TENDERER

REGIONAL PROJECT DIRECTOR

KERALA RURAL WATER SUPPLY AND SANITATION AGENCY

FORMAT Q 3

STATEMENT SHOWING THE VALUE OF WORKS TAKEN UP, COMPLETION TIME OF WORKS DURING THE PAST TEN YEARS INCLUDING WORKS IN KRWSA

USE SEPARATE PHOTOCOPIED SHEET FOR EACH PARTNER

Sl No	Name & Nature of Work	Place and location of work	Agency /Authority for whom work was done (give also designation of the officer tendering the work and order No:	Date of agreement.	Value of completed work	Period of completion as per agreement.	Actual period of completion -	Other relevant details if any
1	2	3	4	5	6	7	8	9

Name of Tenderer :

TENDERER

REGIONAL PROJECT DIRECTOR

KERALA RURAL WATER SUPPLY AND SANITATION AGENCY
FORMAT Q4
IDENTIFICATION AND FINANCIAL DATA SHEET

- 1 Name of tenderer/ firm :
- 2 Nationality /Country of incorporation :
- 3 Type of incorporation
(Necessary documents duly attested should be attached as proof of registration) :
- 4 Year of incorporation for registered firms
(In case of individuals, date of obtaining **A/B/C/D** class license required to carry out the work.) :
- 5 Registered office / Head office Address :
- 6 Local office address :
- 7 Principal officers who manage the work from head office :

No.	Name	Title / Position	Date appointed

- 8 Principal Officers in Local / Site Office

No.	Name	Title / Position	Date appointed

- 9 Local associate firms or agents :
- 10 Total liabilities : Rs.
- 11 Total assets : Rs.
- 12 Current liabilities : Rs.
- 13 Bank overdrafts (Current) : Rs.

- 14 Net worth (from latest balance sheet) : Rs.
- 15 Annual turnover for last three years(to be given separately for each year)
- Financial Year : Rs.
- Financial year : Rs.
- Financial Year..... : Rs.
- a) Average Annual Turn over : Rs.
- 16 Share holders / own funds : Rs.
- 17 Liquid assets : Rs.
- 18 Stock outstanding : Rs.
- 19 Current assets : Rs.
- 20 Bank reference (attach separately) : Rs.
- 21 Current credit resources /OD facility : Rs.
- 22 Solvency amount : Rs.
- 23 Bonding capacity
- Name of institution(s) :
- Bondable amount : Rs.
- 24 Member of consortium from Republic of India, if any Date of establishment of consortium :
- 25 Value of usual contracts for which firm would tender :
- Maximum : Rs.
- Minimum : Rs.
- 26 Signature :
- 27 Date :

Note: 1. In case the tenderer is not a public limited company, solvency certificate from a Nationalized / Scheduled Bank shall be furnished in Q4A

Note: 2. All the data furnished above shall be as at 30 days or less number of days prior to the last date of submission of bid.

TENDERER

REGIONAL PROJECT DIRECTOR

KERALA RURAL WATER SUPPLY AND SANITATION AGENCY
FORMAT Q4 A
SOLVENCY CERTIFICATE

No. :

Date :

Based on the collateral security produced on movable and immovable property of following descriptions appended to this certificate, I (name),
..... (designation) of
Bank (place) hereby certify in my official capacity that Sri./
Smt. (name and address)
..... registered as class contractor
of as per the certificate of registration
produced by him before me is solvent for an amount of Rs./- rupees
(R u p e e s
.....Only) (in words) as on today. He is enjoying an OD facility up to a
maximum of Rs...../- of which he has availed OD facility of Rs...../- as
on today.

Acc.

(office seal)

Signature :

Name :

Designation :

Counter signed by the tenderer :

Note: the list mentioned above shall be attested by the signatory of bank and countersigned by the tenderer.

TENDERER

REGIONAL PROJECT DIRECTOR

Tenderer

Tendering Officer

KERALA RURAL WATER SUPPLY AND SANITATION AGENCY

FORMAT Q.5

DETAILS OF CONSTRUCTION PLANT AND EQUIPMENTS WHICH SHALL BE USED FOR THIS WORK

Sl. No:	Description of the equipment	Reg. No:	Manufacturer, capacity and year of make	Nos. proposed to be used for this work	Present status of the equipment
1	2	3	4	5	6

The tenderer hereby confirms that the quantity and type of equipment he shall deploy for construction shall not be less than listed above, and agrees to bring more equipment, if so warranted in the opinion of the Engineer in charge, at no extra cost to the KRWSA.

Date:

TENDERER

REGIONAL PROJECT DIRECTOR

KERALA RURAL WATER SUPPLY AND SANITATION AGENCY

FORMAT Q 6

DETAILS OF PERSONNEL WHO WILL BE EMPLOYED BY THE TENDERER FOR THIS WORK

Sl. No:	Name and address	Qualifications	Experience	Specific work in respect of this contract
1	2	3	4	5

The tenderer hereby confirms that the above personnel shall be employed for the purpose of this work and also any additional staff, which in the opinion of the Engineer in charge, shall be employed by the contractor for the satisfactory completion of this work.

Date:

TENDERER

REGIONAL PROJECT DIRECTOR

KERALA RURAL WATER SUPPLY AND SANITATION AGENCY

FORMAT Q7

**PROJECTWISE EXPERIENCE OF WATER TREATMENT PLANT /SEWERAGE
TREATMENT PLANTS**

Name of the Project and location	Name and address of the client (with contact No:)	Name and address of the financing authority (with telephone no: and fax no:)	Scheduled time of completion (months)	Starting date and completion date	Contract value as constructed value (lakhs)	Key persons Who executed the project on behalf of the applicant	Construction plant & equipment used by the applicant in the execution of the project

Notes:

1. Information to be furnished shall include sewerage / water treatment plants of 3 mld or higher capacity. It may include water retaining structures, mechanical / electrical equipments of comparative magnitude.
2. Details to be incorporated may include works completed as well as works in hand.
3. In respect of works in hand, indicate the percentage of completion as on the date of tendering.
4. Separate sheets shall be attached to cover details in the above format for individual numbers.
5. Details of treatment plants shall be furnished separately, indicating clearly the type of process description of units etc.

TENDERER

REGIONAL PROJECT DIRECTOR

KERALA RURAL WATER SUPPLY AND SANITATION AGENCY

FORM Q8

**RECORD OF ARBITRATION &
LITIGATION**

(The applicant shall record chronologically any dispute he had with any of his previous clients during the last 10 years, whether arbitration or litigation and also indicate the nature, duration and amount of claim involved in such cases.)

Sl. No:	Project identification and location	Name and address of the client	Description	Name of	Dispute	Award in favour of client / contractor
				Period of arbitration / litigation from - to	Amount claimed Rs. Lakhs	

Seal of the Company

**Signature
DIRECTOR**

REGIONAL PROJECT

Designation



KERALA RURAL WATER SUPPLY AND SANITATION AGENCY

**Name of Work : Jal Jeevan Mission – Providing Functional Household Tap
Connections – Full Coverage of Bellur Grama Panchayath in Kasaragod District**

E-TENDER No : 001/JJM/KRWSA/RPMU/KNR/BLR/ 2023

**DUE DATE & TIME FOR
UPLOADING OF TENDER BY TENDERER : 04/12/2023, 06.00 PM**

TENDER OPENING DATE : 06/12/2023, 11.00 AM

NOTICE INVITING TENDER VOLUME – II SCOPE OF WORKS

**OFFICE OF THE REGIONAL PROJECT DIRECTOR
KERALA RURAL WATER SUPPLY AND SANITATION AGENCY
RPMU KANNUR
KERALA STATE
TELEPHONE: 0497 2707601
Email ID : rpmukannur@gmail.com**

Price Bid - BoQ

Separately attached

CONTENTS

Sl. No.	Description	Page no.
1	General information about the project and works	80
1.1	Introduction	80
1.2	Community Contribution	81
2	General Scope of the tender	81
3	Site conditions	82
4	General Condition and specification of work	82
4.1	Providing FHTC	82
4.2	Preperation of FHTC file and remittance of fee	83
4.3	Trenching and back filling	83
4.4	Supply of pipes, specials and valves	84
4.5	Pre-delivary inspection of pipes and other materials	85
4.6	Laying of pipes and specials	85
4.7	Hydrostatic pressure testing of pipe line at field	86
4.8	Providing Valves, Mechanical flow meters and Valve chambers	86
4.9	Road restoration	87
4.10	Safety at site	87
4.11	Third party inspection	87
4.12	Maintenance	88
4.13	Handing over of completed work	89
4.14	Assessment of cost of work	89
4.15	Fund flow	89
4.16	Payment	90
4.17	Implementation schedule	90
4.18	Liquidated damages and fine	90
4.19	Providing project information	91
5	Detailed scope and specification of work	91
	APPENDIX – I to III	93
	ANNEXURES – I to III	96

1. GENERAL INFORMATION ABOUT THE PROJECT AND WORKS

1.1 Introduction

Govt. of India have launched Jal Jeevan Mission (JJM) which aims at providing Functional Household Tap Connection (FHTC) to every rural household by 2024. The programme focuses on service delivery at household level, i.e. water supply on regular basis in adequate quantity and of prescribed quality. This necessitates use of modern technology in planning and implementation of water supply schemes, development of water sources, treatment and supply of water, empowerment of Gram Panchayat/ local community, focus on service delivery, partner with other stakeholders, convergence with other programmes, methodical monitoring of the programme and to capture service delivery data automatically for ensuring the quality of services. This will help in achieving the goal of Jal Jeevan Mission in its true letter and spirit. JJM was launched in Kerala by the Hon'ble Chief Minister on 18.06.2020. JJM is envisaged to provide Functional Household Tap Connection (FHTC) to every rural household with 50:50 cost sharing between Central and State Government and the State share includes 15% contribution from Grama Panchayats and 10% contribution from Beneficiaries.

The broad objectives of the Mission are:

- to provide FHTC to every rural household;
- to prioritize provision of FHTCs in quality affected areas, villages in drought prone and desert areas, Sansad Adarsh Gram Yojana (SAGY) villages, etc.;
- to provide functional tap connection to Schools, Anganwadi centres, GP buildings, Health centres, wellness centres and community buildings;
- to monitor functionality of tap connections;
- to promote and ensure voluntary ownership among local community by way of contribution in cash, kind and/ or labour and voluntary labour (shramdaan);
- to assist in ensuring sustainability of water supply system, i.e. water source, water supply infrastructure, and funds for regular O&M;
- to empower and develop human resource in the sector such that the demands of construction, plumbing, electrical, water quality management, water treatment, catchment protection, O&M, etc. are taken care of in short and long term; and
- to bring awareness on various aspects and significance of safe drinking water and involvement of stakeholders in manner that make water everyone's business.

There is a felt need to have community participation, ownership and contribution in all decisions pertaining to water supply systems. Thus, community led partnership with State will be the strategy for achieving the objectives of JJM. The 73rd Amendment to the Constitution of India devolved the responsibility of drinking water supply to local self-governments and provides the constitutional mandate to manage drinking water. To implement the mission, institutional arrangements like Water and Sanitation Mission at National, State and District levels and Water and Sanitation Committees/ Sub committees at Panchayat/ Village level have been made vide Government Orders (**Annexure - III**). Communities can make the best of this opportunity and ensure that every rural household has FHTC delivering water in adequate quantity (minimum 55 lpcd) of prescribed quality (BIS:10500) and on regular basis as may be decided by the Grama Panchayat and/ or its subcommittee, i.e. VWSC/ Paani Samiti/ User Group, etc.

Further, it is necessary that within the villages, local community/ Gram Panchayat and/ or its sub-committee, i.e. VWSC/ Paani Samiti/ User Group, etc. plays the key role for O&M, cost recovery, and good governance. A sense of ownership has to be instilled in the village community as they are at the centre of this mission by way of contributions from Panchayat and Beneficiaries. However, the approach has been predominantly engineering/ construction oriented. This has resulted in limited involvement of communities in design, planning and implementation and KRWSA has to play a critical role in this area. KRWSA has to help Grama Panchayat and/ or its subcommittee to plan, implement, manage, operate and maintain its in-village water supply systems.

1.2 Community Contribution

For in-village piped water supply infrastructure and related source development to be implemented by Gram Panchayat and/ or its sub-committee, i.e. VWSC/ Paani Samiti/ User Group, etc., communities will contribute 5% of the capital cost in cash and/ or kind and/ or labour in villages having more than 50% SCs and/ or STs population; and 10% of the capital cost in other villages. Willingness of the community and contribution as mandated under JJM from at least 80% households of the village is a pre-requisite for taking up water supply scheme. Gram Panchayat and/ or its sub-committee, i.e. VWSC/ Paani Samiti/ User Group, etc. may consider exempting individual contribution from poor, infirm, divyangjan or widow with no source of steady income. However, this is an exception rather than a rule. In order to reduce the burden of community to make upfront contribution in cash, Gram Panchayat and/ or its sub-committee, i.e. VWSC/ Paani Samiti/ User Group, etc. may allow individual households to pay in installments.

Community contribution can be in the form of cash and/ or kind and/ or labour. The contribution made in the form of kind and/ or labour will be computed and the cash equivalent of the same along with the cash contribution will be entered and maintained in a separate register by GP and/ or its sub-committee. The community contribution made in cash towards in-village infrastructure creation will be deposited in the respective Bank account of Gram Panchayat and/ or its sub-committee. This account will be operated jointly by chairperson of Gram Panchayat and/ or its subcommittee, i.e. VWSC/ Paani Samiti/ User Group, etc. and respective Panchayat Secretary. Separate ledgers have to be maintained for receiving community contribution (towards in-village infrastructure creation), incentive received and also for user fee provided by households towards meeting O&M requirements. The community contribution will be paid to Agency/ vendor as decided by DWSM.

Community contribution in the form of kind and / or labour as informed/committed by the GP and/ or its sub-committee shall be ensured during execution by the Engineer-in-charge and the cash equivalent of the same will be arrived for each kind / labour at DSR/ Department Approved Rate. Any material supplied by the beneficiary towards community contribution shall be in accordance with the specified standard approved by KRWSA. This shall be jointly authorized by Contractor, VWSM or its representative and the respective beneficiary.

2. General Scope of the Tender

This work is for providing a total number of 980 new FHTCs and allied water supply infrastructure like construction of OHSR, providing distribution pipe lines, valves, valve chambers, mechanical flow meters etc including restoration of roads after pipe laying, renovation of existing water tank, new OHSR and sump, supplying and installation of pump set and detail Engineering survey in Bellur Grama Panchayath at Kasaragod District as per the BoQ attached. FHTCs are to be provided as per the beneficiary list approved by respective Grama Panchayath. Number of FHTC provided in this Bid Document is purely notional. List of selected households will be intimated by the Grama Panchayath / Scheme Level Executive Committee Bellur. Work shall be executed based on this list and hence the actual number of FHTC will vary accordingly. The connections are to be taken from distribution pipe lines laid in earthen, concrete, tile

paved and bituminous roads (Including BM&BC roads) owned by Panchayath, PWD, KRFB, KSTP or any other agency. Restoration of road surfaces that are dismantled for this project is also included in the scope of the work.

3. Site conditions

Project area includes at Bellur Grama Panchayath at Kasaragod District, soil in this area is predominantly all classes (Ordinary, Medium and Hard rocks). Under water excavation may necessitate in some places for laying pipe lines.

Roads in the project area include Panchayath/ PWD/NH/KRFB/KSTP. Laying of new pipe lines and allied works are proposed along these roads. FHTCs are to be provided from existing and newly proposed pipe lines laid in the roads.

4. General conditions and specifications of work

All the works and materials to be procured for use in construction under this contract should adhere to relevant Indian Standards. Further type of materials to be used under different terrain/conditions should adhere to CPHEEO recommendations for such conditions as the case may be and as amended from time to time. Relevant IS codes to be followed for major items under this contract is listed in Appendix-5. For any item of work for which IS code is prevailing the same shall be followed even if it is not specifically mentioned in the list.

4.1 Providing FHTCs

- a) FHTCs are to be provided to the eligible households selected by the respective Grama Panchayath and Beneficiary Committee jointly and approved by GP. Number of FHTC provided in this Bid Document is purely notional. List of selected households will be intimated by the GP after depositing the Beneficiary contribution and Panchayath contributions to PFMS account. Work shall be executed based on this list and hence the actual number of FHTC will vary accordingly.
- b) FHTCs are to be taken from distribution pipe lines laid in earthen, concrete, tile paved and bituminous roads (Including BM&BC roads) owned by Panchayat, PWD, KRFB, KSTP or any other agency. Road surfaces if dismantled/damaged during the work shall be restored using PCC 1:2:4 immediately on completion of each FHTC. In the case of demolishing required for tile paved roads, the same shall be repacked in original condition after providing necessary compaction as directed by departmental/concerned authorities.
- c) Providing 15mm (1/2 inch) house connection with 15mm (1/2 inch) water meter from existing PVC / HDPE mains up to 110 mm dia., up to a length of 5 m using 20mm Indian Standard Class 6 uPVC pipe and uPVC / GM / Brass specials viz. brass ferrule, GM full way wheel valve, Elbow, MTA, FTA, couplers, PVC Service Saddle of suitable size etc. and connecting with the mains, testing the joints etc. complete including trenching and refilling in all kinds of soil up to a depth of 1.50m for main line tracing and trench of average cross section 0.3m x 0.75m for laying connection pipe and service pipe, fixing water meter, lighting, watching, providing caution boards, traffic control etc. complete including cost of materials, hire for tools, cost of consumables and labour charges, including the cost of tested Class B Multijet water meter with ISI mark and weather resistant PP / PE meter box of minimum size 300mm x 200mm x 150mm, stand post with 63 mm 6kg/cm² pvc pipe height of 1 mtr, concrete palform of size 60*60*7.5cm, but excluding charges for cutting the concrete / tarred / bituminous roads etc, and as per the direction of the departmental officers.
- d) **Water meter used for the work shall be multi jet class B tested satisfactorily in concerned KRWSA offices. The flow meters shall be with brass bottom and transparent top lid and inside plastic material must be in**

virgin plastic as per IS 702. The same shall have two year replacement warrantee. The water meter shall be fixed in each site only in the presence of departmental officers and as per their direction

- e) FHTC works shall be carried out as per the directions of departmental officers. The connection shall only be provided through the licensed plumbers. If the contractor is not a licensed plumber, a notary attested MoU signed between the contractor and licensed plumber / plumbers for a validity period covering the time period of contract shall be submitted to by the successful bidder on award of work for executing the agreement. The original MoU shall be submitted to the Agreement Authority and attested copy may be kept with the contractor and plumber.
- f) File for individual FHTC shall be prepared and submitted as per the prevailing practice in KRWSA with relevant documents including ownership certificate, ID proof (preferably Aadhar), property tax receipt etc. and dimensioned sketch mentioning location & size of pipe in Auto Cad along with application for installation including 2 Nos. stamped and addressed envelope. The sketches in Auto Cad in triplicate should show the plan of rooms as per water supply manual. The position of the mains to which connections are to be made shall be shown in red ink up to meter point and inside installations in blue ink.
- g) GPS position of connection point and water meter shall be marked and submitting as digital file.
- h) For providing FHTCs, KWA Technical Circular No 02/2020 dated 03.08.2020 shall be strictly followed.

4.2 Preparation of FHTC files and remitting the fee

Preparation and submission of files for providing FHTC to the beneficiaries selected by the GP and approved by KRWSA shall be accompanied by all required documents like ownership certificate, any ID proof – preferably Aadhar, property tax receipt etc. collected from the consumer by the contractor.

- a) The contractor shall capture the details of assets created and Geo-tag them and shall link the created FHTC to head of the household through Aadhar.
- b) After completing all connection works the contractor shall arrange the final soft and hard copy of ward level list of beneficiaries with name, address and contact number, category (SC/ST/GEN/Fisheries) adhar number, water meter number and geo coordinates. The list should be authorized by GP Secretary.

4.3 Trenching and Back filling

- a) Earth work excavation for laying pipes, providing FHTCs, construction of valve chambers and anchor blocks etc shall be made in all types of soil like all kinds of soil, Ordinary rock and medium rock. Tentative percentage of all kinds of soil, Ordinary rock and medium rock the project area are 43%, 43% & 14% respectively. However this is only a general assessment and the bidders shall make a detailed survey of the project area and make their own assessment of soil classification and quote the bid accordingly. No additional claim for change in soil classifications, if occurred during execution of the work shall be allowed.
- b) Excavation for laying of pipes shall have to be done in lines so as to provide a minimum cover of 90cm above the crown of pipes to be laid except for small diameter pipes (below 40mm) laid in narrow lines without vehicular traffic. The requirement of minimum cover may increase up to 120 cm above the pipe crown where the pipes are to be laid in National Highways/KSTP Roads. Also, the depth of excavation may further increase where the pipe line shall have to cross existing utilities or culvers or drains as decided by the Engineer in charge, based on specific site conditions.
- c) All necessary sanctions for Excavating and laying pipes along NH/PWD/KRFB/KSTP/Panchayat roads and related road crossings, Railway crossings shall be obtained jointly by KRWSA and Panchayat.

- c) While trenching, damages should be minimum to the roads. If concrete or bituminous surfaces are required to excavate or dismantle, the sides of the proposed alignment of trenches on such concrete/bituminous surfaces shall be cut with mechanical cutting machine for a minimum depth of 200mm before excavation in order to minimize damages to the surfaces.
- d) Care shall be taken to ensure that hindrance to vehicular and pedestrian traffic due to the work is minimum.
- e) Order No.KWA/JB/WS1/2297/11 dated 7.11.2014 issued by the MD, KWA regarding the precautions to be taken while cutting roads for laying pipes is applicable to KRWSA also and should be strictly followed.
- f) Changing the alignment of excavation towards the bituminous/concrete surfaces for the purpose of saving specials is not allowed. If such instances are noted, the additional restoration amount required to make good of such damages shall be recovered from the payments due to the contractor.
- g) Only selected fill materials free of stones and sharp aggregates shall be used for refilling the trenches to a height of 30cm from the top of pipe line. All the back filling shall be watered and compacted using mechanical compactors in layers not exceeding 20cm depth to avoid further settlement of refilled portion. Any excess of soil after refilling the trenches shall be removed from the site by the contractor and disposed off with in a distance of 10 km as directed by the Engineer in charge. For conveying and disposing excess earth, Government orders and procedures in this regard shall strictly be followed.
- h) Damages to structure like culverts, retaining walls, buildings etc caused during work shall be fully rectified by the contractor at his own cost to the satisfaction of the respective owners of the structures. Compensation, if any, for such damages shall be met by the contractor alone.

4.4 Supply of pipes and Specials and Valves

- a) Contractor shall supply all pipes, specials and valves required for the satisfactory completion of the work as part of this tender as indicated in List of pipes and specials attached to this bid document indicate only tentative quantities and the contractor shall conduct detailed survey along the proposed alignments of pipe line and assess the actual necessity at site. Supply of only required quantities are to be made after getting approval of the Regional Project Director/Manager Technical.
- b) The specials such as bends, Tees, saddle pieces, Reducers, GM valves/ ferule valves (IS Specification) etc shall be suitable for the above size pipes
- c) The cost of laying pipe shall be quoted inclusive of the cost of all specials and jointing materials and also labour charges.
- d) In case the pipe specials are fabricated, all such fabrications shall be done as per the direction of departmental officials. For fabrication of MS pipes, MS sheets of minimum 8mm thickness and for fabrication of MS flanges, MS sheets of 12mm thickness shall be used
- e) The Engineer in charge or the agreement executing authority shall have the right and authority to direct the tenderer to fabricate any specials for which standard specials are not available. Cost of all such fabrications shall be deemed to have included in the amount quoted by the tenderer. No extra claim will be admissible in all such cases.
- f) In addition to the quantities required for laying, the contractor shall supply spare pipes, specials, valves and flow meters as per the BoQ.
- g) Conveyance, loading, unloading and stacking of pipes and other materials required for the execution of the work shall be the responsibility of the contractor. The such as pipe, specials, Valves, water meter etc shall

be supplied by the contractor before starting the work and stacked in his safe custody and shall be intimated to the concerned Engineer in charge, ready for inspection at any time.

- h) Two copies of complete list of Vendors/Manufacturers from whom the valves, specials etc. can be procured, along with the product specification brochure/product identification number etc. shall be submitted by the contractor on completion of the work.

4.5 Pre-Delivery Inspection of Pipes and Other Materials

Pre-delivery inspection all pipes and valves shall be through the third party inspection agency fixed by KRWSA. The pre-delivery inspection of all pipes and valves shall also have to be witnessed by a KRWSA Engineer as deputed by the agreement authority. The cost of all such inspection will have to be borne by the contractor as per the terms and conditions.

The agreement executing authority will have the option to depute an officer of KRWSA for witnessing the pre-delivery testing by the third party inspectors. Inspection Certificate should be produced before the despatch of materials from the factory and only after written communication and verification & acceptance of the inspection report, the materials shall be despatched to the site. Third party inspection is mandatory for all pipes, specials and pumping and electromechanical equipments supplied by the contractor. Also ISI marked materials shall alone be accepted, wherever ISI specifications is available for such item. However, positive results observed during pre-delivery inspection and the acceptance of the inspection report / result by Kerala Rural Water Supply and Sanitation Agency / Agreement authority will not anyway relieve the contractor from his responsibility on the quality of materials supplied by him at the work site. The contractor is liable to replace the pipe, specials, valves, pump sets, electro mechanical equipments or any other item supplied as a part of this tender if the same is found defective/obsolete/not confirming to relevant IS standards in later stage

Any disputes between the contractor and the supplier for inspection agencies or on any subject related to the work shall be a matter of settlement among both of them and Kerala Rural Water Supply and Sanitation Agency shall not be a party to such disputes. The amount quoted shall be inclusive of the cost of all materials and charges of inspection as specified.

4.6 Laying of pipe and specials

- a) Laying of pipe lines shall be done in the roads and alignments as specified by the Engineer-in-Charge of the work
- b) Crossing of roads, bridges and culverts shall be done by providing GI covering pipes at exposed portion. The contractor shall consult with the PWD/local body authorities to finalize the alignment and method of pipe laying at culvert and bridge crossings. Protection to the exposed pipes in the form of RCC blocks or casing pipes shall be provided. The contractor shall assess the actual no. of culverts/bridges at site before supplying and laying pipes.
- c) While laying the pipe lines, if any culvert or a part of the bridge etc is getting damaged, its rectification should be done by the contractor at his cost and necessary protection of pipe laid should also be done by means of anchor block or pillars as per directions of the Engineer-in-charge.
- d) All pipe lines carrying potable water shall be properly disinfected by suitable method before commissioning. Chlorine water shall be allowed to remain in pipe lines minimum for 24 hours during which time all valves hydrants shall be operated to ensure proper disinfection. Any rectification works if needed at the time of commissioning shall be done by the contractor without extra claim.

- e) Anchor blocks should be provided wherever necessary, as per the direction of the Engineer-in-charge, to avoid dislocation of the pipes. The design of the anchor block provided should be got approved by the Manager Technical before commencement of work.
- f) Scouring the line to the nearest point of disposal may be made with pipes of respective material and class and of suitable sizes.
- g) A 20cm thick layer of red earth cushion free from Stones, boulders, sharp/angular materials etc is to be provided at the bottom of the pipe trenches where the excavated bed of trench is rocky and the pipe line shall be placed firmly over such cushion.
- h) After completion of laying work, necessary rubble packing/ cross bar if required, is to be made at sloping portions to avoid the erosion of soil from the top of the pipe as per the direction of Engineer-in-charge.
- i) If the length on actual execution is found to be at variance with length specified in the scope of work, the contract amount shall be considered to have changed proportionate.

4.7 Hydrostatic pressure testing of pipe lines at field

After laying the pipe lines, hydrostatic pressure testing shall be done in reaches of not more than 200m in length, as per the relevant IS specifications/CPHEEO manual, to or as advised by the Engineer in charge so as to ensure that the pipes and joints are sound enough to withstand the maximum pressure likely to be developed under working conditions. Contractor shall not be allowed to proceed with the pipe laying work leaving more than 2 reaches of pipe lines untested. The joints of all pipes and specials shall be kept open with necessary fencing / safety arrangements until the testing is completed satisfactorily. The water required for testing the pipe lines, the dummy pipes and test pumps etc shall be arranged by the contractor at his own cost. Contractor shall maintain a record of testing of pipeline which shall be got signed by an officer not below the rank of Project Commissioner which shall be produced along with his request for release of security deposit and shall be presented to any inspecting officer above the rank of Manager Technical. The field test pressure and duration of time shall be as per the prevailing IS specifications.

4.8 Providing Valves, Mechanical flow meters and Valve chambers

Supply and fixing Sluice valves, air valves and mechanical flow meters in the pipe line network in the points specified by Engineer-in-Charge is included in the scope of this work. Valves and flow meters shall conform to the relevant IS standards and their tentative numbers are as shown in BoQ. However, these numbers are only tentative and the contractor shall supply and fix additional numbers if the Engineer-in-Charge directs so. Body of the Valves shall be made of Cast Iron/Ductile Iron and shall be of pressure rating not less than PN 1.60. Air valves shall be equipped with Gun metal gate valves of appropriate size for the purpose of isolating the same from the pipe line in order to facilitate repair works if required in future.

Mechanical flow meters shall be of Class B, Woltman type and of ARAD/ZENNER/REYCHEM RPG/ITRON make. Flow meters shall be tested and certified by FCRI Palakad before fixing and the cost of testing shall be borne by the contractor.

RCC chambers with M25 mix shall be provided for Valves and flow meters as per the dimensions attached. Before construction, their design shall be got approved from Engineer-in-Charge of the work. Tentative numbers of Valve chambers to be provided is as specified.

4.9 Restoration of Roads

Tentative quantities of items proposed for restoring the road surfaces are included in the BoQ, this quantity may vary in accordance with site requirements and the contractor shall be bound to execute additional quantity, if any as directed by Engineer-in-Charge. Trenches shall be refilled in layers not exceeding 20cm in depth and shall be consolidated by watering and ramming. Excess earth if any shall be disposed as directed by Engineer-in-charge and all government rules and procedures in this regard shall be strictly observed.

4.10 Safety at site

Contractor shall ensure all measures at site to ensure the safety of men, machinery and property. Contractor alone shall be responsible for any damage that may occur at site due to lapses in safety measures. Contractor shall provide necessary caution boards and fencing as per the direction/specification of KRWSA for the trenches during the progress of work. Minimum 3 Nos. caution boards shall be placed in the approaching side and 2 Nos. at the leaving side at the required distances as per the relevant safety codes. They shall also provide sufficient shoring to the sides of trench to prevent collapse of trenches and consequent damages to men and materials wherever the depth of trench exceeds 1.50 m or while excavating near other civil structures. During night hours contractors shall provide sufficient lighting and watching at site.

Fencing shall be provided to the sides of pipe line trenches and around other working spaces and shall be maintained intact until the work is completed and trenches are properly consolidated so that pedestrian and vehicular traffic can be resumed as before. Under normal conditions, fencing of 1.50m high with two rows of reflecting plastic caution tape tied in vertical casuarina poles of girth 15 to 24 cm fixed at 2m interval is required. If the Engineer-in-Charge find that the site condition requires more caution, fencing of 1.50m high with two rows of casuarina poles of girth 15 to 24 cm tied in vertical casuarina poles of girth 15 to 24 cm fixed at 1.5m interval shall be provided.

In case the contractor fail to provide necessary protection work such as fencing, shoring etc. as required at the site, the Engineer in charge will have the power to deduct the charges of such work at department rates from the payments due to the contractor for the work done by him at such sections. Contractor shall arrange for necessary bailing out water for trenching and pipe laying works and the rate quoted by the contractor shall be inclusive of all incidental charges such as shoring and any other protection to the sides of trenches. Protections to the telephone and electric post, convenient re- alignment of existing utilities within the proposed alignments, taking all site safety measures such as providing fencing, lighting and watching of the work site, bailing out water etc. complete should be done by the contractor. No claim for any extra items will be entertained against any of the incidental changes that may arise out of contingencies associated with the completion of the work. The quoted rate shall be inclusive of all these incidental charges.

4.11 Third party inspection

For all works under Jal Jeevan Mission (JJM), third party inspection and certification before payment is mandatory. SWSM will empanel third party verification agencies based on the ToR issued by Department/ National Mission, to check the quality of work executed by the agencies, quality of materials used for construction and quality of machinery installed in each of the scheme

On request for release of running payment from the executing agency, a combined inspection of site will be undertaken by:

- i.) Gram Panchayat and/ or its sub-committee, i.e. VWSC/ Paani Samiti/ User Group, etc.
- ii.) KWA/ KRWSA and

iii.) Third-party inspection agency empanelled by SWSM based on criteria developed by DDWS.

The agreed discussion points will be recorded and signed in a separate 'works register' created for this purpose with Gram Panchayat and/ or its subcommittee, i.e. VWSC/ Paani Samiti/ User Group, etc. Based on this, KWA/ KRWSA will record the measurements in Measurement Book (MB) and process further for making payment;

Terms of Reference (ToR) of third party inspection agencies:

i) To carry out inspection of all engineering works relating to civil, mechanical and electrical components executed under in-village infrastructure covering the following aspects

a. Sample checking of:

- test report of the materials used for construction
- quality control measures adopted at the time of construction in the field
- safety measures adopted at the time of construction in the field
- payment for labour by the executing agency.

b. Quantity and quality of works executed as per the bill for payment claimed

c. Recommendations on the payment for the work executed.

d. Functioning of the in-village infrastructure during trial run

ii) To carry out inspection of all engineering works relating to civil, mechanical and electrical components executed works executed other than in-village infrastructure (intake structures, treatment plants, intra and inter district distribution network, balancing/ intermediate reservoirs, pumping and electrical systems etc.) covering the following aspects

a. Sample checking of

- test report of the materials used for construction
- quality control measures adopted at the time of construction in the field
- safety measures adopted at the time of construction in the field
- payment for labour by the executing agency

b. Quantity and quality of works executed as per the bill for payment claimed

c. Recommendations on the payment for the work executed.

d. Functioning of the infrastructure during trial run

iii) Any other work as decided by the State Government/ UT Administration from the point of view of third party inspection.

4.12 Maintenance

Maintenance of all system/components installed as a part of this work for a period of **12 months** and **18 months** if WTP included from the date of commissioning of the scheme as specified in clause 8.24 of Vol.I is included in the scope of this work. Contractor shall attend all maintenance/defects/breakdowns happened to system/components installed as a part of this work with in 24 hours from the time of occurrence of such complaint and shall be rectified with in reasonable time period. If the contractor fails to

attend the complaints in time, KRWSA shall take up the repair works and the expense and losses incurred in this regard along with penalty shall be recovered from the contractor.

If the system/components installed as part of this works remains defunct due to the failure from the part of the contractor in rectifying the defects in time, the maintenance period shall be considered to be extended further for such period during which the system/component remained defunct.

4.13 Handing over of completed work

Contractor shall hand over System/component installed as part of this work to KRWSA as a whole after completing all the works envisaged in the scope of this tender. Handing over documents shall accompany

- a) Necessary list of items installed under this contract
- b) Two copies of complete list of Vendors/Manufacturers from whom the valves, specials etc. can be procured, along with the product specification brochure/product identification number etc.,
- c) Digital and hard copies of as laid drawings of pipe lines network indicating type, size and class of pipes, size and location of valves and flow meters etc.
- d) List of FHTC provided under the work with location, Ward No. House No. Mobile No. AADHAAR No. APL/BPL Status etc for each Beneficiary.

4.14 Assessment of cost of work

Tenderer shall assess separately the expenditure that may have to be incurred for each of the items and provide an itemized schedule of such works without mentioning rates. Any item of work which has not been specifically mentioned in this scope of work but are found imperative for the satisfactory completion of work shall be considered as included in this scope of work and no claim for any extra item will be entertained unless specifically approved by the agreement authority.

Tenderer should furnish the names of suppliers of each item if he is not a manufacturer of the same. He should also furnish the full particulars regarding method of execution of work or any other relevant information of the technical bid in cover B-

4.15 Fund flow

- a) All transactions under JJM are to be made mandatorily through PFMS and instructions issued from Government of India on PFMS from time-to-time need to be followed. Fund utilization by States/ UTs under JJM will be monitored through PFMS. Release of funds in future will be linked to the fund availability and utilization in PFMS and physical and financial progress monitored through IMIS.
- b) SWSM will open a single nodal account in any scheduled commercial bank. The releases by the Government of India to the State Government will be made to their State treasuries from where States will be transferring the fund to the single nodal account of SWSM within 15 days along with the corresponding matching State share. The Integrated Management Information System (IMIS) software would support Accounting System and would be enabled to allow rural water supply department/ SWSM and Bank branch concerned to make data entry online for the transactions to be made by them. The State Government/ SWSM will decide about the matching fund as per the prescribed funding pattern. On receipt of the Central and State share of JJM by the SWSM in the single nodal account, its allocation among the Districts, based on the annual district action plans (DAP) finalized by the respective SWSM shall be made within two weeks. DWSM will get the work implemented as per the DAP and fund available at the district

level, through Gram Panchayat and/ or its sub-committee, i.e. VWSC/ Paani Samiti/ User Group or PHED/ RWS Department as the case maybe.

- c) After execution of the work, KRWSA will raise the bill to DWSM/ SWSM as the case may be, who in turn will get the work inspected by an empaneled third-party agency. Thereafter, subject to due satisfaction of quality and quantity of work performed, the DWSM/ SWSM, as the case may be, will arrange to make the payments to the agency. The payments advice in PFMS mode will be raised by the DWSM/ SWSM to make payment to the agency for the executed works subject to fund allocation/ drawl limit set for the district by SWSM for that particular year. No advance to any other account be made except to that of executing agency towards mobilization advance as per contractor

4.16 Payment

The Engineer in charge will record the bill in Measurement Book and payment will be released only after successful completion and trial running of FHTC and inspection and functionality assessment by the third party inspection agency engaged by the District Water and Sanitation Mission (DWSM). Functionality of a tap connection is defined as having infrastructure, i.e. household tap connection providing water in adequate quantity, i.e. at least 55 lpcd, of prescribed quality, i.e. BIS:10500 standard, on regular basis, i.e. continuous supply in long-term. The payment will be released to the contractor through PFMS within 30-45 days after third party inspection and subject to the availability of fund.

A payment schedule will be prepared by the tendering authority, mutually agreed between bidder and the tendering authority which will be the basis of payment. Payment will be released as per the approved payment schedule and Clause 8.16 of NIT Vol I. Supply of materials shall be done in a phased manner as per the supply schedule approved by the tendering authority as specified in Clause 9.14 of NIT Vol I.

4.17 Implementation schedule

The work shall be completed in all respects **within 100 Days** and the commissioned scheme shall be **maintained for a further period of 12 months** from the date of commissioning of the work. In case any maintenance works are attended by KRWSA during this period **of 12 months** due to failure on part of the contractor to turn up and complete the work, suitable fine/penalty as per the NIT Vol.1 shall be implemented on the contractor.

The contractor shall submit a properly designed schedule bar chart and CPM network showing his plan of action for the completion of the project. The total project shall be divided into a minimum of 6 activities and the planed progress should be indicated clearly.

The contractor shall give a procurement schedule which shall indicate the date of his order of materials at site, lot sizes, etc. complete which will be used to assess the progress of the work.

4.18 Liquidated damage and fine

If the contractor fails to maintain the required progress as per conditions of contract or to complete the work and clear the site on or before the contract or extended date of completion, he shall, without prejudice to any other right or remedy available under the law to the Employer on account of such breach, pay to the employer as liquidated damages in accordance with clause 8.10.1 of NIT Vol.I

Selection Notice- In the selection notice the selected contractor will be notified to execute an agreement within a maximum period of fourteen days from the date of acceptance of the tender.

If the successful bidder fails to execute the agreement within 14 days or with fine within stipulated period, tendering authority shall cancel the offer of contract forfeiting the EMD and taking such other actions as

mentioned in the bidding document. After cancelling the offer of contract in the above case, the tendering authority may negotiate with the next lowest bidder and award the work to him if he expresses his willingness in writing to execute the work at the accepted rate of the defaulted bidder. Otherwise the work will be re tendered.

4.19 Providing Project information

In order to ensure transparency and the whole village to be informed about the programmer, sign board of 8x6ft to be erected at a conspicuous location(s) giving all relevant details of the scheme viz, JJM logo, total cost of the scheme, implementing agency/vendor, name and contact number of JJM Volunteer/SE/PC/Pani samiti chair person and Secretary, commencement and completion date of the work etc

5 . Detailed scope and specifications of work

This work is for providing a total number of **700** new FHTCs and allied water supply infrastructure like, construction of OHSR, providing pumping mains and distribution pipe lines, valves, valve chambers, flow meters etc. including restoration of roads after pipe laying, New Sump, water tank and renovation of water tank etc. in Chaliyar Panchayath at KANNUR district as per BoQ attached. **The work is also aimed to benefit existing FHTCs in addition to the new FHTCs mentioned above and necessary interconnection works with the existing lines shall also be done** as per the directions of the Regional Project Director. FHTCs shall be provided as per the beneficiary list approved by KRWSA. Restoration of road surfaces that are dismantled for this project is also included in the scope of the work. The quantity mentioned in the NIT for different items in the following clauses are for easy information and the bidders shall quote the rate for all items of work as per the Pricebid BoQ even if any items are not mentioned in the NIT.

1. FHTC

The total tentative number of new FHTCs to be provided is **1070**. The FHTCs are to be provided from existing/newly proposed pipe lines.

These lines are existent / proposed along Panchayath/PWD/NH/KRFB/KSTP roads. Number of FHTCs proposed from various size of distribution lines and in various roads are as summarized below

Size of distribution line	Number of connections to be given	Existing connections to be benefitted
DI/PVC /HDPE /GI/AC etc. Pipes of various dia	980	0

2. Laying pipe lines

Supplying and Laying DI/uPVC/GI pipes as pumping mains and distribution lines for an approximate length of **65,534 m** is included in the scope of this work in addition to the house connection pipes. Tentative length of various type, size and class of pipes that are required to lay are listed below. The actual quantities shall be as per the approved hydraulic design and site conditions.

Item	Qty	Uit
100.98.211 : Supply of uPVC Pipe, IS 4985: 2000 , 6kg/cm2, 63mm Dia..	1192.8000	metre
100.98.230 : Supply of uPVC Pipe, IS 4985: 2000 , 10kg/cm2, 25mm.	12405.3000	metre

100.98.231 : Supply of uPVC Pipe, IS 4985: 2000 , 10kg/cm2, 32mm Dia.	11505.0000	metre
100.98.232 : Supply of uPVC Pipe, IS 4985: 2000 , 10kg/cm2, 40mm Dia.	8880.0000	metre
100.98.233 : Supply of uPVC Pipe, IS 4985: 2000 , 10kg/cm2, 50mm Dia.	7353.5000	metre
100.98.234 : Supply of uPVC Pipe, IS 4985: 2000 , 10kg/cm2, 63mm Dia.	3837.5000	metre
100.98.235 : Supply of uPVC Pipe, IS 4985: 2000 , 10kg/cm2, 75mm Dia.	2605.0000	metre
od51594/2021_2022 : Supply of PVC Pipe,12.5kg/cm2,75mm Dia	700.0000	metre
100.98.236 : Supply of uPVC Pipe, IS 4985: 2000 , 10kg/cm2, 90mm Dia.	4100.0000	metre
od51595/2021_2022 : Supply of PVC Pipe,12.5kg/cm2,90mm Dia	500.0000	metre
100.98.237 : Supply of uPVC Pipe, IS 4985: 2000 , 10kg/cm2, 110mm Dia.	3199.0000	metre
100.98.238 : Supply of uPVC Pipe, IS 4985: 2000 , 10kg/cm2, 140mm Dia.	717.0000	metre
100.98.239 : Supply of uPVC Pipe, IS 4985: 2000 , 10kg/cm2, 160mm Dia.	740.0000	metre

The contractor shall conduct detailed study and anticipate any extra/excess items required and quote accordingly. However, if there is any reduction in quantities, payments for the scheduled items will be made only for the quantity executed.

3. Service Reservoirs and sump

The scope of works includes design and construction of an OHSR, sump and allied Works at proposed sites as per the direction of Tendering Authority.

Sl. No.	Component	Type	Capacity (Litre)
1	Storage tank	RCC OHSR	50000
2	Sump	RCC GLSR	15000

All levels shall be verified and confirmed at site before starting construction to ensure head. The contractor shall conduct detailed study and anticipate any extra/excess items required for the completion of the OHSR and sump quote accordingly. However, if there is any reduction in quantities, payments for the scheduled items will be made only for the quantity executed.

4. Valves

Supplying and fixing of Air valves and control valves in the pipe line network is part of this work. Air valves shall be equipped with Gun metal gate valves of appropriate size for the purpose of isolating the same from the pipe line in order to facilitate repair works if required in future. Both Air valves and Control valves shall be made of Cast Iron/Ductile Iron and shall be of PN 1.60 pressure rating. Supply and fixing valves shall be as per schedule and the hydraulic design.

5. Valve chambers

RCC chambers with M15 PCC bottom , and M25 floor slab, side wall and cover slab shall be provided for Air valves, Sluice valves and Mechanical flow meters as per the direction of Engineer in Charge. Before construction, their design shall be got approved from the Engineer-in-Charge of the work. Valve chambers shall be provided as per schedule.

6. Temporary Road restoration

Trenches shall be excavated with minimum damages to the road surfaces. Restoration of road surfaces that are dismantled / damaged during this work is included in the scope of this tender. Trenches shall be refilled in layers not exceeding 20cm in depth and shall be consolidated by watering and ramming. Excess earth if any shall be disposed as directed by Engineer-in-charge and all government rules and procedures in this regard shall be strictly observed. Top 10cm depth of trenches and top 20cm in road crossings shall be concreted in P:C:C 1:2:4 using 20mm aggregates. If tiled surfaces are dismantled, the same shall be restored back to the original position with dismantled tiles or new tiles if the dismantled tiles are damaged. No separate claim will be entertained for the same.

7. Survey and design

Survey and design of pipe lines/storage tanks/sump is included in the scope of this work. Selected bidder should complete the survey and design of all components within 20 days of signing the agreement as per the conditions of NIT. Factory test and supply of materials at site as per the direction of Authority should be completed within next 10 days. Contractor should submit detailed design report, drawings and colour copy of line diagram of pipe lines to be laid and got approved from the Authority before the commencement of work. The work plan submitted by the contractor should bind to this clause.

8. 2sets of Pumpset and accessories with 18.96 lps discharge against a total head 178 m is included in the scope of this work and must be bound to the specification given in BoQ. Head and discharge should be ensured by the contractor before installing at site and variations any should be considered while quoting.

9. Testing the water sample (both physical & bacteriological parameters) from source of the scheme in any government laboratories and submitting the report after completion of work or at the time of demand by Engineer in charge is included in the scope of project.

APPENDIX - I:

FORM TP1

**TENTATIVE REQUIREMENT OF VARIOUS COMPONENTS,
PIPES AND VALVES**

Providing 980 new FHTCs in Bellur Grama Panchayath in Kasaragod District

Item	Qty	Uit
100.98.211 : Supply of uPVC Pipe, IS 4985: 2000 , 6kg/cm2, 63mm Dia..	1192.8000	metre
100.98.230 : Supply of uPVC Pipe, IS 4985: 2000 , 10kg/cm2, 25mm.	12405.3000	metre
100.98.231 : Supply of uPVC Pipe, IS 4985: 2000 , 10kg/cm2, 32mm Dia.	11505.0000	metre
100.98.232 : Supply of uPVC Pipe, IS 4985: 2000 , 10kg/cm2, 40mm Dia.	8880.0000	metre
100.98.233 : Supply of uPVC Pipe, IS 4985: 2000 , 10kg/cm2, 50mm Dia.	7353.5000	metre
100.98.234 : Supply of uPVC Pipe, IS 4985: 2000 , 10kg/cm2, 63mm Dia.	3837.5000	metre
100.98.235 : Supply of uPVC Pipe, IS 4985: 2000 , 10kg/cm2, 75mm Dia.	2605.0000	metre
od51594/2021_2022 : Supply of PVC Pipe,12.5kg/cm2,75mm Dia	700.0000	metre
100.98.236 : Supply of uPVC Pipe, IS 4985: 2000 , 10kg/cm2, 90mm Dia.	4100.0000	metre
od51595/2021_2022 : Supply of PVC Pipe,12.5kg/cm2,90mm Dia	500.0000	metre
100.98.237 : Supply of uPVC Pipe, IS 4985: 2000 , 10kg/cm2, 110mm Dia.	3199.0000	metre
100.98.238 : Supply of uPVC Pipe, IS 4985: 2000 , 10kg/cm2, 140mm Dia.	717.0000	metre
100.98.239 : Supply of uPVC Pipe, IS 4985: 2000 , 10kg/cm2, 160mm Dia.	740.0000	metre

APPENDIX - II

List of IS CODES to be followed

IS 456-2000	Reinforced Cement Concrete
IS 3370-2009	Part 1&2 Concrete structures for storage of water
IS 1893-2002	Part1 Earthquake resistant design
IS 10500-1991	Drinking water
IS 8329-2000	DI pipes
IS 4985-2000	PVC pipes
IS 3589-2001	MS pipes
IS 1239 part1-2004	GI pipes
IS 269-2013	Cement OPC
IS 1489-1991	Cement PPC
IS 1536-2001	CI pipes
IS 8329-2000	DI pipes
IS 1848-2000	Air valves
IS 1846-2000	sluice valves
IS 4984 – 2016	PE Pipes
IS 7634(Part2)-2012	Laying & Jointing PE pipes

Above IS codes with latest amendment to be followed

APPENDIX - III
DRAWINGS

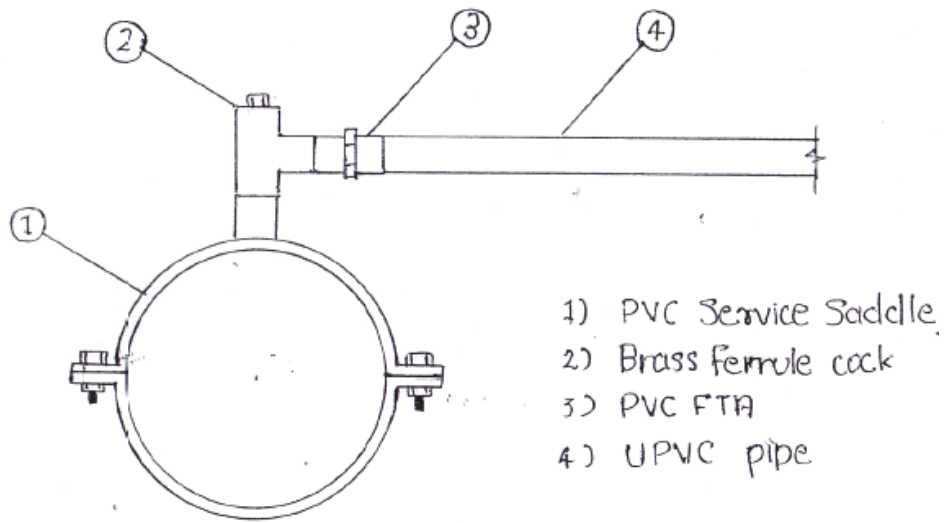

Figure 1. House connection drawing 1

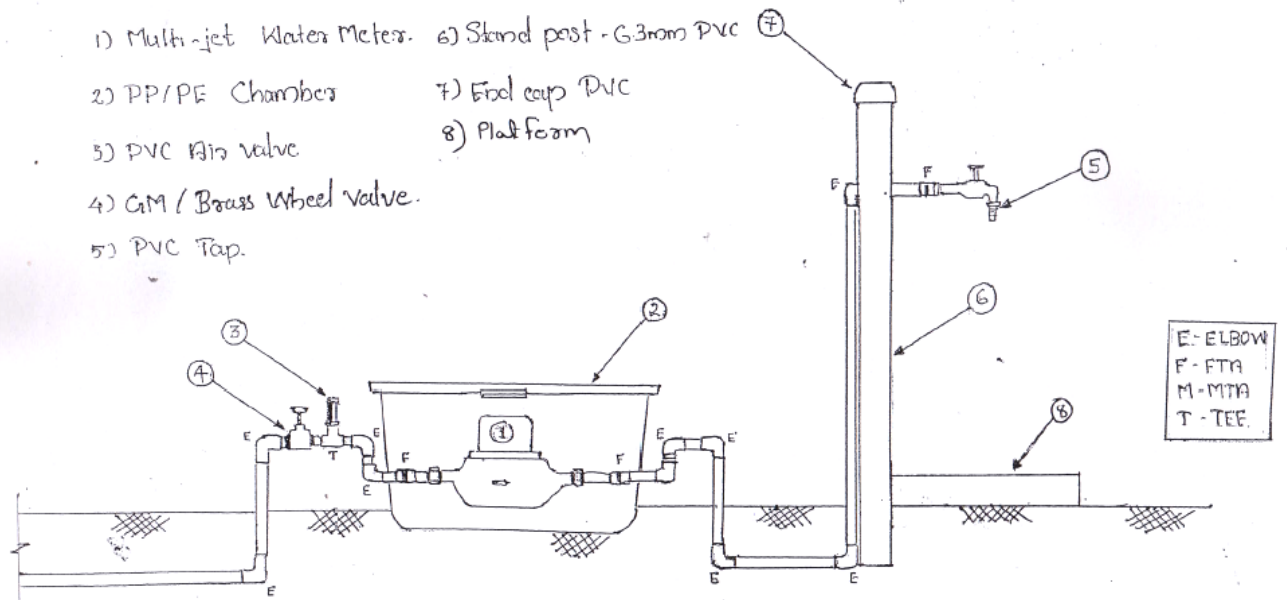

Figure 1. House connection drawing 2

ANNEXURE - I:

FORM OF DECLARATION OF NON RELATIONSHIP

1. FORM OF DECLARATION OF NON RELATIONSHIP

1. I..... do here by declare that none of my relation as per the list given in Section 6 and Schedule 1 A of the Companies Act, 1956 is in charge of the above work or are having control over it.

Contractor

Note: If the contractor is found at any stage to have suppressed any information required, his earnest money for the Work is liable to be forfeited and the contract entered in to will stand cancelled.

ANNEXURE II
APPROVED PRE-QUALIFIED VALVE MANUFACTURERS' LIST OF KERALA
WATER AUTHORITY
Ref. No.KWA/HO/SP-9624/2013-14/Valves dtd.03.07.2014
(Subject to Validity)

Sl. No.	Name of Manufacturer
1.	M/s. Calsen Private Limited, Mechanical Division,6/1 A, British Indian Street, Calcutta – 700069
2.	M/s. Kirloskar Brothers Ltd, Valve Business Unit Kondhapuri, Gat No. 252/253 Tal-Shirur, Dist – Pune
3.	M/s. Sigma Flow Control Limited, Tobacco House, Room #506, 5 th floor, 1&2, Old Court House Corner, Kolkata 700001.

ANNEXURE - III:

MAJOR GOVERNMENT ORDERS/APPROVALS FOR CONSTITUTING
MISSION / COMMITTEES