

KERALA RURAL WATER SUPPLY AND SANITATION AGENCY

Name of Work:-

Construction of 138Nos. open well recharge and 12Nos. Homestead open wells into Protected, Sanitized wells diameter up to 2m and upto 6m with recharge pit, under State Plan Scheme 2021-22, Alakode GP, Kannur District.

NOTICE INVITING TENDER

VOLUME – I

Tender No : 111/KRWSA/KNR/DWS&R/ALKD/2022-23

Tendered PAC : Rs.35,85,952/-

Last date of online submission of tenders : 18/05/2023, 06.00 PM

Date of tender opening : 20/05/2023, 11.00 AM

**KERALA RURAL WATER SUPPLY AND SANITATION
AGENCY, REGIONAL PROJECT MANAGEMENT UNIT
KANNUR**

Tenderer

Tender Inviting Officer

CONTENTS

Chapter	Description	Page No.
1.	Tender Notice	3
2.	Detailed Tender Notice	5
3.	Letter Submitting the Tender	8
4.	Particulars showing the status of tenderer	9
5.	Forms of Agreement	10
6.	Definitions and Interpretations	13
7.	Tender Conditions - Part: I	15
8.	Tender Conditions - Part: II	24
9.	Tender Conditions - Part: III	34
10.	General Technical Specifications	48
11.	Scope of Work & Bill of Quantities	53
12.	Design	57

Tenderer

Tender Inviting Officer

OFFICE OF THE REGIONAL PROJECT DIRECTOR
KERALA RURAL WATER SUPPLY AND SANITATION AGENCY
Regional Project Management Unit , Kannur-670002
Tel-04792707601, Email-rpmukannur@gmail.com

E-TENDER NOTICE

The Regional Project Director - KRWSA, Kerala Rural Water Supply and Sanitation Agency, Regional Project Management Unit, Kannur-2 invites sealed competitive electronic tenders in Single level system for the work detailed below from the contractors having valid and eligible contract licence A, B and C class registration from KPWD/KWA/CPWD/LSGD/Govt of India and Govt institutions. Registered NGOs having the following qualifications are also permitted to attend the e-tender process.

1. Experience in Civil works during the last ten Financial Years. (Experience Certificate, issued by agreement authority should be uploaded while submitting the tender.)
2. The NGO should have a valid registration certificate.
3. The NGO should have a minimum annual turnover of **Rs.10** lakhs per year in the last three financial years (**Turnover Certificate, signed by the concerned auditor shall be uploaded while submitting the tender**).
4. The NGO should produce the audited accounts for the last three financial Years.

This tender is an e-Tender and is being published online for the Project **“Construction of 138Nos. open well recharge and 12Nos. Homestead open wells into Protected, Sanitized wells diameter up to 2m and upto 6m with recharge pit, under State Plan Scheme 2021-22, Alakode GP, Kannur District.**

The tender is invited in ONE cover system from the registered and eligible firms through e-procurement portal of Government of Kerala ([https://www .etenders.kerala.gov.in](https://www.etenders.kerala.gov.in)). Prospective bidders willing to participate in this tender shall necessarily register themselves with above mentioned e-procurement portal.

The tender timeline is available in the critical date section of this tender published in www.etenders.kerala.gov.in.The brief details of tender are as follows.

Tender No	111/KRWSA/KNR/DWS&R/ALKD/2022-23
Name of Project	Scaling up of Rain Water Harvesting and Ground Water Recharge Programme, under State Plan Scheme 2021-22
Name of work	Construction of 138Nos. open well recharge and 12Nos. Homestead open wells into Protected, Sanitized wells diameter up to 2m and upto 6m with recharge pit, under State Plan Scheme 2021-22, Alakode GP, Kannur District.
Nature of works	Construction of 138Nos. open well recharge and 12Nos. Homestead open wells into Protected, Sanitized wells diameter up to 2m and upto 6m with recharge pit, under State Plan Scheme 2021-22, Alakode GP, Kannur District.

Tenderer

Tender Inviting Officer

Location	In the premises of households in Alkode Grama Panchayath, Kannur District
Probable Amount of Contract:	Rs.35,85,952/-
Source of Fund for this work:	State Plan Funds
Budget provision for the year	2021-22
Sale of Tender Documents	Documents are available in the site www.etenders.kerala.gov.in for free download
Tender forms received by	Regional Project Director, Regional Project Management Unit, KRWSA, Near AKG Hospital, Thalap, Kannur -670002.
Tender fee:	Rs.2,500/- + GST (GST to be paid by the bidder on reverse charge basis while filing his returns)
EMD:	Rs.50,000/-
Mode of payment (Tender fee & EMD)	online payment
Pre-bid meeting	10/05/2023 at 11.00 AM
Corrigendum	Corrigendum if any will be published in website www.etenders.kerala.gov.in
Last date and time of submission of tenders electronically to the tendering Authority	18/05/2023 at 05.00 PM
Date and time of opening of tenders	20/05/2023 at 11.00 AM
Validity of Bid(Firm period)	90 days from the last date of submission of bid(electronically)
Place of execution of agreement	Regional Project Management Unit, KRWSA, Near AKG Hospital, Thalap, Kannur -670002.
Period of completion of work	3 Months from the date of Agreement.

Interested bidders can get further details regarding the work from the office of the **Regional Project Director, KRWSA, Regional Project Management Unit, Kannur, 670002 04792707601, Email- rpmukannur@gmail.com** All other relevant rules followed by KRWSA shall be applicable.

Regional Project Director -
KRWSA, Regional Project
Management Unit,
Kannur 670002

Tenderer

Tender Inviting Officer

KERALA RURAL WATER SUPPLY AND SANITATION AGENCY

2. DETAILED TENDER NOTICE

1. Sealed competitive electronic tenders are invited for and on behalf of **Regional Project Management Unit, Kannur - KRWSA, K R W S A** by the undersigned from contractors having valid and eligible contract licence **A B and C** class registration from KPWD/KWA/CPWD/LSGD/Govt of India/Govt institutions. Registered NGOs having following qualifications are also permitted to attend the e-tender process.
 - a. Experience in **Civil works during the last ten Financial** Years. (**Experience Certificate**, issued by agreement authority should be uploaded while submitting the tender.)
 - b. The NGO should have a minimum annual turnover of **Rs.10 lakhs** per year in the last three financial years (**Turnover Certificate**, signed by the concerned auditor should be uploaded while submitting the tender).
 - c. The NGO should produce the audited accounts for the last three financial Years.
 - d. The NGO should have a valid Registration Certificate.

Name of project: Conversion of homestead wells into Protected sustainable drinking water sources under State Plan Scheme 2021-22

Name of Work: **Construction Of 138Nos open well recharge and Construction of 12Nos. Homestead open wells into Protected, Sanitized wells diameter up to 2m and upto 6m with recharge pit , under State Plan Scheme 2021-22, Alakode GP, Kannur District**, as per the list approved by GP. The bidder shall fill up technical bid sheet and price bids in prefixed formats and upload in the website along with NIT Vol. I & II.

2. Intending tenderers may enroll themselves for e-tendering in the website www.etenders.kerala.gov.in. One time registration is valid for all KRWSA tenders. The contractors/NGOs who are registered for e-tendering and have valid password can only view / download the Tender Documents. The Tender Schedule shall be filled up in the prescribed format provided in tender document. For uploading the tender documents, the tenderer has to remit the amount towards cost of tender documents as well as the prescribed EMD through online payment mechanism for e-procurement system of Govt. of Kerala. Tenderers are advised to visit the "Downloads" section of e-Procurement website (www.etenders.kerala.gov.in) for detailed instructions on making online payment using internet banking facility of SBI or by using NEFT facility. Only those tender schedules which are downloaded from the website and uploaded after filling only will be considered. Bidders can make use of the links "help for Contractors", "FAQ", "Bidders Manual Kit" etc. in the above website for more details on registration and bid submission. For further assistance they can also contact over phone or by mail to the regional offices of Kerala State IT Mission in the addresses available in the website.

The tenders shall be submitted electronically to the **Regional Project Director - KRWSA, Regional Project Management Unit, Kannur 670002** in the method available at the web site www.etenders.kerala.gov.in. The tenderer has to remit the amount towards cost of tender documents and EMD through online payment in time. The bid submission is allowed up to the last date and time given in this tender notice. Submitting bid documents in no way for a right or / eligibility for pre-qualification of awarding the work. The pre-qualification criteria are described in the bid document. The price bid shall be submitted electronically only.

The bidder shall fill up the prequalification sheet, technical bid sheet and price bids in prefixed formats along with NIT, Scope of work or any other document uploaded by the **Regional Project Director - KRWSA** and upload in the website. Additional documents, if any are to be scanned and uploaded in the

website. The price bid shall be submitted electronically only. The tenderer shall produce before the originals of the documents uploaded including those scanned and uploaded (except price bid) with the preliminary agreement executed in Kerala Stamp paper (Rs.200). In the event of discrepancy between the scanned copy and the original submitted or if the tenderer fails to submit the documents within the prescribed time, the tender submitted by the tenderer will be summarily rejected and the EMD forfeited.

Technical Bid shall be opened in the presence of the Bidder or their authorized representative who chooses to attend the specified tender opening. After the evaluation of Technical Bid, the **Regional Project Director** - KRWSA will intimate the bidders who have qualified in Technical bid, the date and time of opening of the Price bid which will be fixed subsequently. The participating bidders can view the bid opening online and view the rates of competitors after tender opening. Bidders are requested to furnish Telephone No/Fax No/Email ID for speedy transfer of information.

Regional Project Director - KRWSA will not be responsible for any cost or expenses incurred by bidders in connection with preparation or delivery of bid or loss of any document during transit. Date extension will not be allowed without specific reasons and which is beyond the control of KRWSA. In the event of any of the specified date being declared a holiday, the event will take place at the same time and place on the next working day. All other conditions of invitation of tenders will be as per prevalent rules in KRWSA.

3. Deleted.

4. The pre-bid meeting will be on **10/05/2023 at 11.00AM**. The clarifications if any will be published in the web. These clarifications will form part of tender documents and copy of same shall be uploaded and submitted duly signed in hard copy.

5. Period of completion of the work tendered will be **3 (Three) months** from date of agreement.

6. The tenders shall be submitted electronically before **06.00 PM on 18/05/2023**. The bidder shall fill up the prequalification sheet, technical bid sheet and price bids in prefixed formats along with NIT, Scope of work or any other document uploaded by the **Regional Project Director** - KRWSA and upload in the website. Additional documents if any are to be scanned and uploaded in the website. The price bids in prescribed should be submitted electronically only.

7. The tenders shall be opened at **11.00 AM on 20/05/2023**. The bidders are advised to be present for the opening of tender or they can view the opening through the web site. The electronically submitted price bid of those contractors whose technical bids are at par with the N.I.T only will be opened by the **Regional Project Director** - KRWSA after giving due information about the time and date to all the selected bidders in advance and in the presence of the bidders present at the time of opening. The decision of the **Regional Project Director** - KRWSA, regarding the eligibility to be selected for the opening of the financial bids will be final and it shall not be appealable. Tenders without requisite EMD and other particulars shall not be considered further but will be retained with KRWSA.

8. The cost of tender form, for this tender is not refundable even though the tender is cancelled or rejected at any stage.

9. Deleted

10. The contractors who are black listed by competent authority or lagged two or more works of KRWSA shall not be eligible to participate in this tender.

Tenderer

Tender Inviting Officer

2. LETTER SUBMITTING THE TENDER

(Shall be submitted in this format after filling the details along with hard copies)

Ref. No.

Place

Date

From

To

The Regional Project
Director, Regional
Project Management
Unit, KRWSA, Kannur

Sir,

Sub: and as per the list approved by GP. The bidder shall fill up technical bid sheet and price bids in prefixed formats and upload in the website along with NIT Vol. I & II.

Ref: Your e- tender Notification No. **111/KRWSA/KNR/DWS&R/ALKD/2022-23**, D a ted 09/05/202

1. I/We.... as the duly authorized person (s) in my/our official capacity as..... of the aforesaid firm, hereby submit this tender for your consideration. I / we have read and understood all conditions of this document in full spirit and meaning. I/We hereby agree to accept all the conditions put forth in the tender document without any deviations or with the exceptions, which may be expressly admitted and accepted by the tender accepting authority before the award of work. Preliminary agreement duly executed and signed in Rs.200/- worth stamp paper is also enclosed. Copy of the specifications duly signed is also enclosed.

2. EMD for **Rs.50,000/-** has been remitted through Credit Card / Net Banking.

3. I / We further agree to complete the whole work in all respects within **3 (Three) months** from date of agreement.

4. I/We agree to keep the tender open for acceptance for a period of **90 days** from the last date prescribed for submission of tender.

5. I / We agree that Agency shall without prejudice to any other right or remedy be at liberty to forfeit the said earnest money absolutely if

(a) In case we fail to keep the tender open as aforesaid or make any modifications in the terms and conditions of the tender.

(b) After the Tender is accepted, I/We fail to execute the agreement as provided in the tender conditions or to commence the execution of work as provided in the condition.

6. The tender submitted is fully in accordance with NIT and I / we agree to all NIT conditions and any other conditions prevailing in KRWSA in to to.

7. I have not included any conditions in quoting for this tender.

Yours faithfully

(Office Seal)

SIGNATURE WITH NAME AND DESIGNATION

Tenderer

Tender Inviting Officer

4. PARTICULARS SHOWING STATUS OF TENDERER

(Shall be submitted in this format after filling the details along with hard copies)

4.1.1 Name of tenderer :

4.1.2 Address

(a) Permanent :

(b) Present for communication :

(c) E-mail ID, Fax,

Telephone(land/mobile) :

4.1.3 Status of the tenderer/individual or public Ltd. Co. or Private Ltd Co. or registered partnership concern or proprietary concern or Registered NGO. :

4.1.4 Name and address of Chairman of Board of Directors and Managing Director/Managing Partner (in case of partnership concern) or Proprietor (in case of proprietary concern)

[Memorandum of Articles and Authorization/ Partnership deed] :

4.1.5 Whether the tenderer is a registered contractor of KWA/ any State /Central Government Department. (CPWD, MES, Railway etc) or local bodies (ie. Port Trust, District Board, Municipality or a statutory body) with Reg. No. and year and issuing authority :

4.1.6 Name and address of two responsible persons (Preferably Senior Engineers / Officers of a Government Department, Quasi Government organization or a local body/Regional Project Directors or Manager, Rain Centre of KRWSA), to whom reference can be made regarding experience and performance :

4.1.7 Whether Authorization to act on behalf of the firm presented or not :

SIGNATURE WITH NAME & DESIGNATION
(OFFICE SEAL)

Tenderer

Tender Inviting Officer

5. FORMS OF AGREEMENT

(A) FORM OF PRELIMINARY AGREEMENT

“Preliminary Agreement entered on this day of Two Thousand .between Regional **Project Director, Kerala Rural Water Supply & Sanitation Agency**, Regional Project Mangament Unit, Kannur For and on behalf of KRWSA of the one part and Sri, .. (full name and address of the tenderer) hereinafter called the contractor of the other part for the execution of the agreement as well as for the execution of the project **Construction of 138Nos. open well recharge and 12Nos. Homestead open wells into Protected ,Sanitized wells diameter up to 2m and upto 6m with recharge pit , under State Plan Scheme 2021-22, Alakode GP, Kannur District.**

KRWSA invited tenders for the work by Notification No**111/KRWSA/KNR/DWS&R/ALKD/2022-23**, dated **09/05/2023** of the notice inviting tenders stated as follows:

Within **fifteen days** after the date when the acceptance of the tender has been intimated to him, the tenderer shall deposit a sum sufficient to make to the balance which together with the amount of earnest money deposited shall be created as security for the proper fulfilment of the same and shall execute an agreement for the work in the stipulated manner. If he fails to do this or in the case of the contract to maintain a specified rate of progress (to be specified in each case in the tender schedule) the earnest money and security deposit shall be forfeited to KRWSA and fresh tenders shall be called for or the matter otherwise disposed off. If as a result of such measures due to the default of the tenderer to pay the required deposit to KRWSA results in any loss to KRWSA, the same will be recovered from him as arrears of revenue. The original contractor shall have no claim whatever to the sum that may be due to the contractor on this or any other subsisting contracts or under the Revenue Recovery Act or otherwise the KRWSA may decide.

NOW THESE PRESENT WITNESS AND it is mutually agreed as follows:

The terms and conditions for the said contract having been stipulated in the said tender form to which the contractor has agreed, a copy of which forms part of this agreement, it is agreed that the terms and conditions stipulated therein shall bind the part to this agreement extend to which they are abrogated or altered by express terms and conditions herein agreed to and in which accept the express provisions herein all supersede those of the same tender form.

1. The contractor hereby agrees and undertakes to perform fulfil all the operations and obligations with the execution of the said work project **“Construction of 138Nos. open well recharge and 12Nos. Homestead open wells into Protected, Sanitized wells diameter up to 2m and upto 6m with recharge pit, under State Plan Scheme 2021-22, Alakode GP, Kannur District.**

2. If the tenderer does not come forward to execute the original agreement after the said work is awarded and selection notice issued in his favour commits breach of any of the conditions of the contract as stipulated in the NIT as quoted above within the period stipulated therein may rearrange the work otherwise or loss so sustained by the KRWSA can be realized from the tenderer under Revenue Recovery Act as if arrears of land revenue as assessed, taking into consideration the prevailing PWD rate and after giving due notice to contractor. The acquisition taken by such authority officer or officers shall be final and conclusive and shall be binding on the contractor.

3. The tenderer further agrees that any amount found due to KRWSA under or by virtue of this

Tenderer

9

Tendering Officer

agreement shall be recoverable from the contractor from his EMD and his properties movable and immovable as arrears of Land Revenue under the provisions of the Revenue Recovery Act for the time being or in any other manner as the KRWSA may deem fit in this regard.

4. The tenderer further assures it is clearly understood that the settlement of claims either by part bills or by final bills will be made only according to the availability budget provision and allotment of funds to the work under respective heads of account in which the work is sanctioned and arranged and also subject to seniority of such bills. No claim for interest or for damages whatsoever shall be made for the belated settlement of claims of bills.

IN WITNESS WHERE OF Sri. -----(here the name of the officers of the KRWSA) for on behalf of the KRWSA and Sri -----
----the tenderer have set their hands on the day and year firm above written signed by Sri -----
-----officer / officers of KRWSA.

Regional Project Director.

In the presence of witness

- 1.
- 2.

Signed and delivered by

Sri , the contractor

- 1.
- 2.

Note: - The form should be presented in Rs. 200/- valid stamp paper of Govt. of Kerala.

(B) FORM OF FINAL AGREEMENT TO BE EXECUTED ON AWARD OF WORK

AGREEMENT NO.-----

ARTICLES OF AGREEMENT made on the ---- Day of ----- **2023** BETWEEN Regional Project Director, Kerala Rural Water Supply and Sanitation Agency, Regional Project Management Unit, Kannur (hereinafter referred to as Regional Project Director - KRWSA which expression shall where the context so admits or implies be deemed to include his successors in office and assigns) acting for and on behalf of the Kerala Rural Water Supply and Sanitation Agency (KRWSA) of the one Part and (----- Name & Full Address of Contractor / Agency-----) (hereinafter called the contractor which expression shall where the context so admits or implies be deemed to include his heirs, executors, administrators successors in interest , legal representatives and assignees as well) of the other part.

WHEREAS Kerala Rural Water Supply and Sanitation Agency (hereinafter called the Agency) are desirous of executing the work, ----- (name of work) ----- as per the Accepted Schedule.

AND WHEREAS the contractor has deposited at least Fifty percent(50%) of Performance Guarantee shall be in the form of Treasury Fixed Deposit and the rest in the form of **Bank Gaurantee** ---- (Performance Security details) ----- as security for the due performance of this contract.

AND WHEREAS the contractor has also agreed to being bound by all the conditions and clauses of the CPWD DSR and all the Standard Specifications for items of works described by a standard Specification.

AND WHEREAS the contractor has agreed to execute the work subject to the conditions, specifications and drawings in the tender document and schedules forming part of this contract (hereinafter referred to as the „said conditions“) the work shown upon the drawings and described in the said Specifications and set forth the Accepted Schedule for a sum of Rs. -----/- (Rupees -----Only) or such other sums as may be arrived at under the Clause of the Standard Preliminary Specifications relating to „Payment on lump-sum basis or by final measurement at unit prices.

Now it is hereby mutually agreed as follows:

- (1) In consideration of the payment of the said sum of Rs. -----/- (Rupees ----- Only) or such other sum as may be arrived at under the Clause of the Standard Preliminary specification relating to „payment on lump-sum basis or by final measurement at unit prices“ the contractor will upon and subject to the said conditions execute and complete the works shown upon the said drawings and described in the said specifications and to the extent of the probable quantities shown in Accepted Schedule with such variations by way of alternations of, additions to, or deductions from the said works and method of payment therefore as are provided for in the said conditions.
- (2) **The term Regional Project Director, in** the said conditions shall mean the Head of the Technical Section of the Agency who shall be competent to exercise all the powers and privileges reserved herein in favour of the Agency with the previous sanctions of or subject to the ratification by the **Regional Project Director** - KRWSA in cases where such sanction or ratifications may be necessary.
- (3) The parties to this contract agreed to undertake the condition that arbitration shall not be a means of settlement of disputes or claim or anything on account of this contract.

Tenderer

11

Tendering Officer

- (4) Time shall be considered as the essence of the agreement and the Contractor hereby agrees to commence the work as soon as this agreement is accepted by competent Agency as defined by the Kerala Public Works Department Code and the site (Grama panchayath) is handed over to him as provided for in the said conditions and agrees to complete the work within Six Months from the date of Agreement and to show progress as required.
- (5) All terms and conditions specified in the bid document shall be read and construed as forming part of this agreement and the parties hereto will respectively abide by and submit themselves to the conditions and stipulations and perform the agreements on their parts respectively.
- (6) Upon the terms and conditions of this agreement being fulfilled and performed to satisfaction of the Manager, Rain Centre , the security deposited by the Contractor as herein before recited or such portion thereof as he may be entitled to under the said conditions shall be returned to the Contractor.

IN WITNESS WHEREOF the Contractor, (----- Name & Full Address of Contractor / Agency-----) has here unto set his hand and **Regional Project Director** - KRWSA for and on behalf of the Agency has hereunto set his hand the day and year first above written.

Name and Designation
Contractor's name

Contractor

Regional Project Director

Signature of **Regional Project Director** - KRWSA, }..... on behalf of the Agency

Signature of the Contractor

Signature of witnesses to the signature of the Contractor 1.

2.

REGIONAL PROJECT DIRECTOR - KRWSA

In the presence of witness

1.

2.

Tenderer

12

Tendering Officer

6. DEFINITIONS AND INTERPRETATIONS

1. 'Government' means Government of Kerala.
2. 'Agency/KRWSA' means the Kerala Rural Water Supply and Sanitation Agency.
3. Regional Project Director - KRWSA" means Regional Project Director - KRWSA, Kerala Rural Water Supply and Sanitation Agency, Regional Project Management Unit, Kannur
4. Regional Project Director - KRWSA" means Regional Project Director - KRWSA, Kerala Rural Water Supply and Sanitation Agency, Regional Project Management Unit, Kannur.
5. „Manger Technical “ means Manger Technical at the KRWSA, Kerala Rural Water Supply and Sanitation Agency, Regional Project Management Unit, Kannur.
- 6 Senior Engineer mean Senior Engineer of the Kerala Rural Water Supply and Sanitation Agency, who is in charge of the work
7. Project Commissioner and Technical Supervisor means the authorised Engineer at the Office of the Executive Director, Kerala Rural Water Supply and Sanitation Agency, Thiruvananthapuram
8. „Departmental officers" means officers of Kerala Rural Water Supply and Sanitation Agency, not below the rank of Project Commissioner who is in charge of the work.
9. 'Work' means the work / project to be done as per the description in the tender document.
10. 'Tenderer' means person or persons, firm or partnership or company or consortium of companies or NGO submitting a tender for the work as defined under item 8 supra, either directly or through duly authorized representatives.
11. 'Contractor' means person or persons, firm or partnership or company or consortium of companies or NGO who have entered into contract for the execution of the work.
12. 'Drawing' means the drawing referred to in the tender documents or such other drawings as may from time to time be furnished or approved in writing by the Regional Project Director - KRWSA or Manager, Manger Technical, KRWSA .
13. 'Site' means lands and other places, on, under, in or through which the work is to be executed or carried out or any other place provided by the Agency for the purpose of fulfilment of the Contract.
14. 'Departmental rate' means rate worked out by the Agency based on departmental data and Schedule of Rates plus conveyance plus 10% towards contractor's profit except on the cost of materials issued departmentally.
15. 'Specification' means the instructions, provisions, conditions and detailed requirements contained in the tender documents.
16. 'M.D.S.S' means Madras Detailed Standard Specifications (Latest Edition).
17. „I.S.S" means Indian Standard Specification, ISO means International standard Organisation and BIS means Bureau of Indian Standards.
18. 'B.S.S' means British Standard Specifications.
19. 'Approved / Approval' means approval in writing.
20. 'Day' means a day from midnight to midnight. „Week" means seven consecutive days
21. 'Month' means from the beginning of a given date of calendar month to the end of the proceeding date of the next month.

22. 'Time tested' means the performance of an item is in such a manner that it has successfully withstood the service conditions intended originally for a continuous period of not less than 7 years in the past without having shown any unpredicted and unpleasant effect and thus has proved the worthiness beyond doubt.
23. „Lead Partner/partner in charge“ means the partner who is authorized by an agreement executed by all partners to receive any instructions / communications / payments from KRWSA and to attend any discussions or other activities in respect of this contract on behalf of all partners.
24. 'Testing' When a structure / component / equipment is tested to ascertain its strength / durability /material comparison with respect to design / service loads or performance to the satisfaction of the Technical Supervisor in charge or as stipulated in the scope of work or as per ISS / BSS, or any such standards / specifications, it is defined as testing.
25. 'Trial Running' means putting all components together with the service / design conditions so as to ascertain the individual and combined performance of all works under the scope together, with respect to the design performance for a period specified in the scope of works.
26. 'Commissioning': means having ensured satisfaction in performance with respect to design / Service conditions in testing and trial running putting the works under the scope of work into desired real service conditions from a particular moment of time continuously or otherwise as envisaged.
27. 'Training' means imparting of training to Agency staff with sufficient practical and theoretical knowledge for the operation and maintenance of the service system/scheme and the knowledge for attending to emergency repairs or acting appropriately on emergency situations that may arise during the life time of the system, as included in the 'work'.
28. 'Manual means Manual on Water Supply and treatment third edition Revised and up dated May 1999 (or the latest) of Central Public Health and Environmental Engineering Organization.
29. ' MLD / mld' means Million liters per day.
30. ' LPS / lps' means Litres per second
31. "EPCM" means Engineering Procurement, Construction and Management.
32. "Maintenance” means Maintenance for specified period during the guarantee period mentioned after full commissioning of project.
33. “ETS” Electronic tendering system and “E-tender” means electronic tender.
34. “Tender” refers to all documents submitted by the bidder through electronic media and attachments in hard copy.

KERALA RURAL WATER SUPPLY & SANITATION AGENCY

7. TENDER CONDITIONS: PART-I PRE- QUALIFICATION OF TENDERERS

**[CONDITIONS/ CRITERIAS FOR TWO COVER SYSTEM IS NOT APPLICABLE TO THIS SINGLE COVER SYSTEM
TENDER]**

7.1 **The Regional Project Director- KRWSA, Regional Project Management Unit, Kannur** for, and on behalf of the KRWSA propose to arrange the following work:- : **Construction of 138Nos. open well recharge and 12Nos. Homestead open wells into Protected, Sanitized wells diameter up to 2m and upto 6m with recharge pit , under State Plan Scheme 2021-22, Alakode GP, Kannur District.**

7.2 The successful tenderer shall be entrusted with the work for the completion of the project as described in the "Scope of Works" in Volume II.

7.3 Deleted

7.4 The tenderers who have submitted the bids, shall be considered as pre-qualified for consideration of their bids further only if: the following conditions are satisfied.

Contractors having valid and eligible contract licence **A B and C Class registration** from KPWD/KWA/CPWD/LSGD/Govt of India/Govt institutions. Registered NGOs having the following qualifications are also permitted to attend the e-tender process.

- a. Experience in Civil works during the last ten Financial Years. (Experience Certificate, issued by agreement authority should be uploaded while submitting the tender.)
- b. The NGO should have a valid Registration Certificate.
- c. The NGO should have a minimum annual turnover of Rs. **10** lakhs per year in the last three financial years (Turnover certificate, signed by the concerned auditor shall be uploaded while submitting the tender).
- d. The NGO should produce the audited accounts for the last three Financial Years.

7.4.1. In case the tender is submitted as a joint venture:

- (i) There shall not be more than four partners in a joint venture and one partner shall be designated as lead partner.
- (ii) The lead partner submitting the tender on behalf of the joint venture shall (a) submit complete information pertaining to each such partner and (b) state in the covering letter attached to the tender the name of the lead partner in charge duly authorized for submitting the tender which shall be evidenced by proper power of attorney signed by legally authorized signatories of all the partners.
- (iii) Original or notary attested copy of the agreement confirming the intent of all parties to form a joint venture shall be attached with the tender. It shall also distinctly show:
 - a) The financial participation of each member of the joint venture and the responsibility of each member as regards the planning and execution of the work.
 - b) Name of the lead partner in charge who is authorized to incur liabilities and receive instructions for and on behalf of all/any of the partners of the joint venture during the entire period of the contract including any extended period, as well as

Tenderer

Tendering Officer

- for receiving payments due.
- c) An undertaking to the effect that all the partners of the joint venture shall be jointly & severally responsible for the execution of the contract, in accordance with the terms and conditions of the contract.
 - d) A partner or a design consultant who has joined with the lead partner to compete in this bid shall not compete singly or in association with any other tenderer for this work. The tenderer while submitting his bid shall obtain an undertaking in this regard from his design consultant / partner and produce it along with the technical bid.
 - e) The aggregate of the qualification criteria of all partners together shall be sufficient to meet the requirements as if a single tender only on financial criteria.
 - f) A lead partner of the joint venture shall meet at least 40% of the qualification criteria in terms of annual turnover and net worth and any other partner shall meet at least 25% of the qualification criteria.
 - g) The extent of participation of each partner shall be specified as also experience of all such partners in the relevant field. However, a partner only for design and consultancy shall not be reckoned for the purpose of clause (f) above.
 - h) Where the tender submitted is as per clause (g) above for the purpose of attaining pre-qualification as a design and management consultant of the prime contractor, then full information shall be given on the consultancy firm's proposed participation. An undertaking from the consultant for providing professional assistance to the contractor shall accompany the tender together with the complete details regarding the technical man power and experience of such consultant.
 - i) Status of persons signing the tender on behalf of the firm in the event of the tender being submitted by a firm, the person signing the tender on behalf of the firm shall state his position in the firm as to whether he is the proprietor, partner or Manager etc. He shall also furnish with the tender, the letter or other documents (in original) authorizing him to act on behalf of the firm.

7.4.2. CHANGE IN THE FIRM'S CONSTITUTION

7.4.2.1 In the case of contract entered into by partnership firm, any change in the constitution of the firm shall forthwith be notified by the contractor to the **Regional Project Director** and to the officer with whom the agreement has been executed.

7.4.2.2 The tenderer, shall not without the previous sanction in writing of the agency accepting the tender, execute any power of attorney in respect of any matter implying this contract and any such power of attorney executed without such sanctions shall not be recognized by or be binding up on the Agency either to grant such sanction or to refuse it or revoke a sanction once given.

7.4.2.3 In the case of partners who are in joint venture for executing the agreement, no change in the individuals of the firm shall affect the liability of the person who may sign the agreement. Any such change shall be forthwith notified by the contractor to the Agreement Agency and the **Regional Project Director** for information.

7.5 TENDERS TO BE IN PRESCRIBED FORM

Tenders, which are not submitted in the prescribed form, shall be summarily rejected.

7.6 HOW TO SUBMIT THE BID.

The tenders shall be submitted electronically to the **Regional Project Director - KRWSA, Regional Project Management Unit, Kannur, 670002** in the method available at the web site www.etenders.kerala.gov.in. The tenderer has to remit the amount towards cost of tender documents and EMD through online payment in time. The bid submission is allowed up to the last date and time given in this tender notice. Submitting bid documents in no way for a right or / eligibility for pre-qualification of awarding the work. The pre-qualification criteria are described in the bid document. The price bid shall be submitted electronically only.

The bidder shall fill up the prequalification sheet, technical bid sheet and price bids in prefixed formats along with NIT, Scope of work or any other document uploaded by the Regional Project Director - KRWSA and upload in the website. Additional documents if any are to be scanned and uploaded in the website. The price bid shall be submitted electronically only. The tenderer shall produce before the originals of the documents uploaded including those scanned and uploaded (except price bid) with the preliminary agreement executed in the prescribed Kerala Stamp paper (Rs.200). In the event of discrepancy between the scanned copy and the original submitted or if the tenderer fails to submit the documents within the prescribed time, the tender submitted by the tenderer will be summarily rejected and the EMD forfeited.

Volume I -This part should contain NIT and relevant details as per the NIT conditions. This should also contain all information required for the pre-qualification of the tenderer, such as copies of details of works done previously, work in hand etc.

Volume II- Scope of work and Bill of Quantities.

7.7 HOW TO SUBMIT PRE-QUALIFICATION BID

7.7.1 It is mandatory that pre-qualification application shall contain the following.

- a. Contractors attending the bidding shall attach the copy of Contract license through electronic Medias.
- b. NGOs" shall submit information called for in Clause No.7.17.1 with supporting documents submitted through electronic media.

7.7.2 Deleted

7.7.3 All details furnished should be complete and as applicable four months prior to the last date of submission of tender.

7.7.4 Applicants are particularly advised to fill the details strictly as per the para 7.17.1. Applications will be rejected if required details are not furnished and if it do not meet the minimum qualifications/ requirements mentioned anywhere in this document. **Any formats furnished in lieu of prescribed formats will not be accepted.** The applicants may furnish any additional information, which in his opinion will highlight his capacity to perform, along with the attachments.

7.7.5 While, applications are under c o n s i d e r a t i o n , applicants and their representatives or other interested parties are advised to refrain from contacting by any means KRWSA officers on matters related to the applications under scrutiny. Applicants will not be Tenderer Tendering Officer

permitted to change the substance of their applications after they have been opened. Noncompliance with these provisions shall be a cause for disqualification.

7.7.6 No firms/ partner of any firm, consultant including design consultant or individual be who have submitted the tender for a work shall associate with any other bidder in the particular tender. EMD in such cases shall be forfeited both the tenders will be treated as rejected

7.8 HOW TO SUBMIT THE TECHNICAL BID (Cover – B Part II)

7.8.1 There shall be a brief description of the systems offered as a prelude to the bid under the title "Brief description of the systems offered" and numbering each of the paragraphs. This shall be followed by details of the civil structures under the title "Particulars of civil works." This shall contain the particulars regarding length, breadth, total height, water depth and sizes of the different

Components and the specifications of the materials proposed for construction of the various parts of these components and the method of execution.

The tenderer is bound to execute all the works described in NIT even though if it is not expressed in brief description of systems offered by the contractor.

7.8.2 The details shall, wherever possible, be furnished in the form of rows and columns (Tables) for enabling a quick evaluation of the offer,

7.8.3 A preliminary design substantiating the above shall be enclosed.

7.8.4 Drawing required for explaining the scope of work is appended in annexure 1.

7.8.5 Deleted

7.8.6 Deleted

7.8.7 The documents of the Technical bid as per Clause: 7.8.1 to 7.8.4 shall be arranged in the same order.

7.8.8 The itemized schedule of works explained under the scope of works is furnished in the Part 2. The cost or rate shall not be disclosed anywhere in this sheet, as it shall render the tender invalid.

7.8.11 ALTERNATE OFFERS AND DEVIATIONS

Any alternative offer deviating from the scope of work and specifications provided in the NIT will not be entertained and shall render the tender invalid.

7.9 HOW TO SUBMIT THE PRICE BID

7.9.1 The price bid in format BOQ should be submitted electronically only. **The cost or rate shall not be disclosed anywhere in this sheet, as it shall render the tender invalid.** The price Bid shall be submitted only in the format specified for that purpose (Form BOQ).

7.9.2 The price bid shall not be used for expressing or putting forth any techno-commercial conditions of the tender. Violation of this stipulation shall result in rejection of the tender after the opening of the price bid even if it may happen to be the lowest.

Tenderer

18

Tendering Officer

7.9.3 VARIATION OF PRICE BID

The tenderer is bound to carry out the work as per the specification at the quoted rate. Nothing inferior to specification as per the scope of work included as part of this NIT shall be acceptable. Price variation on any account shall not be permitted if not explicitly specified otherwise in this NIT and the tenderer is expected to follow sound engineering practices in his designs and cost calculations. Changes in statutory taxes/levies, if any, shall be applied on cost of pipe in case of pipeline works, involving pipe supply. In all such cases the duties, levies, and taxes in percentage that he has considered in the quoted amount and the cost of pipes shall be declared by the tenderer while submitting his price bid. Any escalation/ reduction in statutory duties and levies will be applied only on the basic price of pipes and specials. No escalation in statutory taxes, duties and levies etc. shall be allowed beyond the original approved period as per the procurement schedule, accepted and included in the agreement.

7.10 ATTESTATION OF CORRECTIONS AND ADDITIONS

Care shall be taken to prepare the tenders without corrections/over writings / erasing etc. However, if any corrections, additions or pasted slips shall become necessary, the same shall be signed by the tenderer.

7.11 LANGUAGE AND CORRESPONDANCE OF THE TENDER

Tenders shall be submitted in English and all information in the tender shall be in English. Information in any other language shall be accompanied by its translation in English. However, the details as read in the English text will be governing. Failing to comply with this direction may be considered as a sufficient reason for disqualifying a tender. Any communication should be in writing. Tenderers can make correspondence with the tendering authority through E mail, by fax, or by post.

7.12 CERTIFICATE OF NON-RELATIONSHIP

1. Persons related to any officer of the KRWSA, who is in charge of or having control over the work, are strictly prohibited from tendering for the work. Relationship in this respect is restricted to father, mother, husband, wife, son, daughter, brother, sister, nephew, father-in-law, brother in-law, mother-in-law, sister-in-law and first cousin of the officer concerned. The tenderers shall declare that they are not related to any officer of the KRWSA who is in charge or having control over the work.

2. If at any stage, the above condition is found to have been contravened, the earnest money /security deposit of the tendered shall be forfeited and contract entered into shall be cancelled and the work arranged at his risk and cost.

7.13 FIRM PERIOD OF TENDER

Tenders shall be firm for acceptance for a period of **90 days** from the last date prescribed for submission of tender. No tender can be withdrawn or altered before the firm period is over. Any tenderer who withdraws or alters the tender before the expiry of the firm period shall do so at the risk of the tenderer and the earnest money will be forfeited to KRWSA.

Tenderer

19

Tendering Officer

7.14 PERIOD OF COMPLETION, SCHEDULE BAR CHART, AND CPM CHART

The work shall be completed in all respects within **3 (Three) months** from the date of Agreement. This period of execution is inclusive of the monsoon season. C.P.M. chart along with the detailed schedule bar chart shall also be furnished with the tender. The schedule bar chart shall indicate the weightage of each element/activity with respect to the total quoted amount for the project.

7.15 AGENCY ACCEPTING THE TENDER

The final acceptance of the tender vests with the KRWSA/ State Government which is not bound to accept the lowest tender or assign any reason for rejecting any tender. The Agency reserves to itself the right of re- advertising the tender for the work for carrying out the work in any manner that may be deemed fit, subsequent to this invitation of tender.

7.16 EVALUATION OF TENDER

The tender submitted by a tenderer/firm shall be evaluated in two phases.

First stage : Pre-qualification of tenderers

Second stage : Evaluation of price bid of the pre-qualified tenderers.

7.17 EVALUATION OF PREQUALIFICATION APPLICATION

Evaluation as per documents 7.7.1

7.17.1 MINIMUM ELIGIBILITY CRITERIA FOR PREQUALIFICATION.

The applicant must be a well-established Registered contractor/Registered NGO with experience and capabilities in executing works similar to the work tendered. The applicant can either be a single or a joint venture as per clause 7.4.1 of this NIT. The minimum qualification expected for eligibility for pre-qualification will be based on the following.

Contractors having valid and eligible contract **licence A B and C Class** registration from KPWD/KWA/CPWD/LSGD/PWD in other states of India/CPWD/Central/State PSUs.

Registered NGOs having the following qualifications are also permitted to attend the e-tender process.

- a. Experience in Civil works during the last ten Financial Years. (Experience Certificate, issued by agreement authority should be uploaded while submitting the tender.)
- b. The NGO should have a valid Registration Certificate.
- c. The NGO should have a minimum annual turnover of Rs. 10 lakhs per year in the last three financial years (**Turnover Certificate**, signed by the concerned auditor should be uploaded while submitting the tender).
- d. The NGO should produce the audited accounts for the last three Financial Years.
- e. If one tenderer is participating in more than one tender and he becomes the lowest tenderer in more than one bid, he should have financial credentials satisfying the combined financial qualification for award of more than one contract.

Tenderer

20

Tendering Officer

f. ~~KRWSA is inviting seven tenders of same nature on same date under the same Administrative Sanction in which this tender is invited. No bidders will be eligible for award of more than two contracts if found lowest for more than two works on evaluation.~~

7.17.1.1 Deleted

7.17.1.2 Deleted

1. Deleted

2. Deleted

3. Deleted

4. Deleted

5. (a) Deleted

5. (b) Deleted

6. (a) Deleted

6 (b) Deleted

7. A tenderer who has lagged two or more works of KRWSA shall not be considered as pre-qualified.

8. Deleted.

7.17.1.3. ORGANISATIONAL CAPACITY: Copy of contract licence / NGOs Registration certificate to be furnished along with the bid document.

7.17.1.4 TECHNICAL CAPABILITY Deleted

(A) TECHNICAL PARTICULARS AND DESIGN Deleted

B) PROJECT MANAGEMENT STRATEGY

The project implementation programme of the tenderer shall be submitted as a schedule bar chart properly weighed in percentage and loaded with proposed manpower deployment at site. The tenderer along with technical and design proposals shall submit the procurement plan.

7.17.1.5 Deleted

7.17.1.6 In case of joint venture partnership, The experience of the partners may be added together for explaining the capacity for pre-qualification. It should be ensured by the tenderer that all the documents furnished are duly verified and authenticated by him. No additional documents will be accepted after the submission of the tender.

7.18 Offers are liable to be rejected if

- 1) **The information given in the documents found incomplete / misleading or false (such application will be considered as non-responsive)**
- 2) **The facts are misrepresented. (in this case the EMD is liable to be forfeited).**
- 3) **The records of poor performance are found out at any time after submission of bid.**
- 4) **The contractors who are blacklisted or failed to complete the works, or refrained from executing the agreement and completing the work which they had agreed in the tender.**

7.18.1 Tenders will be rejected if

Tenderer

21

Tendering Officer

- 1) **EMD is not proper and sufficient**
- 2) **NIT is not accepted in toto**
- 3) **If the tender is conditional**

7.19 The successful bidders who are qualified in the pre-qualification evaluation will alone be invited for attending the opening of the price bid.

7.19.1 WITNESSING OF TENDER OPENING

Only one authorized representative will be permitted to witness the bid opening at both the occasions as in clause 7 of Detailed Tender Notice in Chapter 2.

7.20 FINAL DECISION MAKING AUTHORITY

The Agency reserves the right to accept or reject any of the applications for pre-qualification without assigning any reasons thereof and Agency's decision shall be final.

7.21 PERFORMANCE GUARANTEE.

(I) **Performance Guarantee**, the amount collected at time of executing contract agreement, will be 3% of the contract value (agreed PAC) and the deposit will be retained till the expiry of Defect Liability Period. At least fifty percent (50%) of this deposit shall be collected in the form of Treasury Fixed Deposit and the rest in the form of Bank FD or any other forms prescribed in the revised PWD Manual. (GO (P) No.7/2021/Fin dated 07.01.2021 & G.O.(P) No.32/2022/Fin dated 15.03.2022)

(II) **Additional Performance Guarantee.**

Additional Performance Guarantee is waived for low quoted items on the condition that the bidder shall furnish an undertaking to execute all low quoted items in full as per contract terms. (GO (P) No.7/2021/Fin dated 07.01.2021 & G.O.(P) No.32/2022/Fin dated 15.03.2022)

7.22 EXECUTION OF AGREEMENTS

7.22.1 Preliminary agreement in Rs. 200/- Kerala Govt. Stamp Paper duly filled up and signed is to be enclosed in Cover A.

7.22.2. The successful tenderer shall before commencing the work, execute an agreement within 15 days from the date of award of the work in Kerala State Government stamp paper of the required value for the due fulfilment of the contract. He shall pay for stamps, forms and legal expenses incidental thereto. Before executing the agreement, the contractor shall finalize his procurement and project implementation schedule, which shall form part of the agreement. In case the tenderer fails to execute the agreement within 15 days, he shall be fined for such lapses as per clause 8.11(B) [c.i]. Any work recorded as done during the period between the award of work and the end of period allowed to execute agreement will be treated as an asset to KRWSA and no claim will be allowed for the selected tenderer. If the successful tenderer fails to deposit the security amount and execute the agreement as specified above, the EMD of the tenderer shall be forfeited to Agency and the work shall be arranged otherwise. If as a result of such measures due to the default of the tenderer to pay the requisite security deposit, sign contracts and take possession of the worksite, the Agency incurs any loss, the same shall be recovered from him, but should it be a savings to the Agency, the original contractor shall have no claims to the difference. Recoveries on this or any other account shall be made from the sums due to the contractor on this account or otherwise as the Agency may decide, including Revenue Recovery Proceedings, as if the loss is arrears of land revenue.

7.23. COMMUNICATIONS TO BE IN WRITING

All notices, communications, references and complaints issued or made by the Agency, the Regional Project Director - KRWSA or by any such officers of the Agency and by the contractor

Tenderer

22

Tendering Officer

with regard to this work shall be in writing and no notice, communications, reference of complaint not in writing shall be valid. All complaint notices, communications and references shall be deemed to have been duly made, given or sent to the Contractor, if delivered to the Contractor or his authorized agents in person with acknowledgement or posted to the address given by the Contractor or his authorized agent and such communication, if sent in service by post shall deemed to have been received by the addressee on the date on which the same should have reached such address in the ordinary course of transmission by post and in other cases, on the day on which the same were delivered or left.

7.24 ORAL AGREEMENTS NOT BINDING

The terms of contract cannot be added to varied or reduced by any oral agreements previous or subsequent to its signature. The Agency will repudiate any such oral agreement.

KRWSA

8. TENDER CONDITIONS: PART-II

8.1 TENDERS ARE TO BE IN PRESCRIBED FORM

All the submittals under this tender shall be in the prescribed form. Tenders that are not submitted in the prescribed form shall be summarily rejected.

8.2 PURPOSE OF THE CONTRACT

All the works executed/ facilities installed under this contract shall perform the services they are intended to do to the utmost satisfaction of KRWSA, without any defects whatsoever for a minimum period of **12 months** from the date of completion and commissioning of the total works covered under this contract.

8.3 ALTERATION IN DRAWINGS SPECIFICATIONS ETC

8.3.1 The preliminary drawings and connected details enclosed are only for the reference of the tenderer. The tenderers shall conduct their own specific studies and detailed investigations based on the scope of works before offering the bid amount.

8.3.2 The Agency shall be at liberty to shift the location of structure or component of work within the periphery of the site shown in the site plan at any stage before the commencement of the actual execution of the work and the tenderer shall have no claims for any extra or enhanced rate on this account.

8.4 EXAMINATION OF THE SITE CONDITIONS, DRAWING ETC

8.4.1 The Agency does not accept any responsibility for the correctness of the description of the preliminary drawing and specifications. These are liable to alterations by omissions, deductions or addition as set forth in the conditions of contract.

8.4.2 The attached preliminary sketches, drawings, specifications, contours etc. may become liable to changes at the present situation. The tenderer should verify and ascertain the correctness of these. The submission of the tender shall deemed to be prima-facie proof that the tenderer has made such an examination and that this tender is based on the actual situations.

8.4.3 The tenderer shall examine carefully the proposal, drawings and specifications. They shall satisfy themselves as to the character, quality and quantities of the work to be performed, the materials to be supplied and the requirements of the contract with reference to the site and soil conditions. If the tenderer finds any discrepancies or omissions in the drawings, specifications or the tender documents or he should be in doubt as to the true meaning of any part thereof he shall make a written request to the Tendering Agency at least 15 days prior to the last date fixed for the receipt of tenders. Clarifications, corrections or modifications considered necessary in the tender documents shall be issued by the Tendering Agency to all intending tenderers who had purchased the tender form. The last date for issuing such clarifications, corrections or modifications shall be 10 days prior to the last date for receipt of tender. The scope of works provide the requirement of Agency in this work

8.4.4 The tenderer shall specifically note that the bearing capacity and other details of soil and sub soil indicated in Appendices is only approximate and that the Agency does not give any guarantee regarding their present accuracy. The tenderers shall carry out their own tests visual and field to ascertain the bearing pressure and other details of soil and sub soil at various points before submitting the tender, if they so desire. The Agency shall in no way be liable for payments of any extra amount on account of any variation in the actual bearing capacity or other details of soil and sub soil resulting in any changes in design of foundation of structures etc.

8.4.5 Deleted

8.5 Deleted .

8.6 PRE BID MEETING

The pre bid meeting will be on 10/05/2023 at 11.00 A.M. Any queries/doubts, which the tenderers may have on the scope of work or tender conditions, shall also be cleared by e-mails / correspondence up to 04.00 PM on 18/05/2023. Any decision regarding changes in NIT conditions / scope of work can be taken and the same will surpass the original conditions.

8.7 SELECTION OF LOCATIONS IN THE SITE

- (a) In respect of structures/works other than pipeline works the proposed structures at the site shall be located in such a manner that the different structures form a compact unit leaving maximum possible area at the site to facilitate future expansion. However, there shall be adequate passage facilities in between, as the circumstances or surrounding areas may demand. Notwithstanding the above condition the tenderer is liable to make essential alterations in the layout during the time of actual execution as may be deemed fit by the Technical Supervisor in Charge at no extra cost.

(b) deleted

8.8 MOBILISATION ADVANCE

No mobilization advance shall be paid to the contractor.

8.9. INCENTIVE Deleted

8.10 PENALTY

Tenderer

24

Tendering Officer

The contractor for the work shall be liable to pay penalty for the delay in executing the agreement, commencing work etc. as per the as per clause 8.11(B) [c.i]. The **Technical Supervisor** in charge shall also have power to measure up the work of the contractor and later such part as shall be unexecuted out of his hands, and to give it to another contractor to complete, in which case, any expense which may be incurred in excess of the sum which would have been paid to the original contractor, if the whole work had been executed by him (of the amount by which it exceeds, a certificate in writing of the Regional Project Director , shall be final and conclusive) shall be borne and paid by the original contractor and may be deducted from any money due to him by Agency under the contract or otherwise, or from his security deposit or the proceeds of sale thereof, or a sufficient part thereof. Imposition of penalty shall be, however, without prejudice to the rights of KRWSA to terminate the contract as per the provisions of the agreement. All other conditions are as per G.O.(P) No.84/97/PW&T dated 19.8.97

8.10.1 LIQUIDATED DAMAGES

8.10.1(a) If the Contractor fails to maintain the required progress in terms of the agreed time and progress chart or to complete the work and clear the site on or before the date of completion of Contract or extended date of completion, he shall without prejudice to any other right or remedy available under the law to the Employer on account of such breach, pay as compensation, Liquidated damages **@ 0.1(zero point one)** percent of the contract price per week of delay or part there off. The aggregate of such compensation / compensations shall not exceed 10 (ten) percent of the total value as shown in the contract. This will also apply to items or group of items for which separate period of completion has been specified. The amount of compensation may be adjusted or set off against any sum payable to the contractor under this or any other contract with the Employer. **(Standard bid document for e-tendering)**

8.10.1(b) The Agreement Authority, if satisfied, that the work can be completed by the Contractor within a reasonable time after the specified time of completion, may allow further extension of time at its discretion as per clause-19. In the event of extension granted being with Liquidated Damages, the Employer will be entitled without prejudice to any other right or remedy available in that behalf, to recover from the Contractor as agreed damages equivalent to **@ 1(one) percent of the** contract price per week of delay or part thereof.

8.10.1(c). If the contractor achieves balance milestones, even though he has failed to achieve initial milestones, and the work has been completed in the specified/original time of completion, the Employer may release the already levied liquidated damages at his sole discretion.

8.10.1(d) The Agreement Authority, if not satisfied that the works can be completed by the Contractor and in the event of failure on the part of the Contractor to complete work within further extension of time allowed as aforesaid, shall be entitled, without prejudice to any other right, or remedy available in that behalf, to terminate the contract.

8.10.1(e) The Agreement Authority, if not satisfied with the progress of the contract and in the event of failure of the Contractor to recoup the delays in the mutually agreed time frame, shall be entitled to terminate the contract.

8.10.1(f). In the event of such termination of the contract as described in clauses 8.10.1 (d) and 8.10.1 (e) or both, the Employer, shall be entitled to recover Liquidated Damages up to ten percent (10%) of the ^{1enderer} ₂₅ ^{Tendering Officer}

contract value and forfeit the Performance Guarantee and Security Deposit made by the Contractor besides getting the work completed by other means at the risk and cost of the Contractor.

8.10.1(g).The Employer may waive the payment of compensation in the case of contracts where milestones are fixed, depending upon merit of the case, on request received from the Contractor if the entire work is completed within the date as specified in the Contract or as validly extended without stipulating any penalty.

8.11 EARNEST MONEY DEPOSIT (EMD) (Amended)

- (A) No exemption shall be allowed for Govt/ Quasi govt. undertakings unless here is specific order from government / KRWSA to that effect for this particular work. Any such order received from KRWSA, if exists, shall be submitted in cover –A EMD Up to and including 2 crore – 1.5% of the estimate PAC subject to a maximum of Rs. 50,000/ - above 2 crore up to 5 crore –Rs. 1 lakhs. (GO (P)No.7/2021/Fin dated 07.01.2021)

(B) FOREFEITING OF EMD

The EMD may be forfeited:

- a) if the Bidder withdraws the Bid after Bid opening during the period of Bid validity including extended period of validity; or
- b) if any modification is effected to the tender documents or
- c) in the case of a successful Bidder, if the Bidder fails within the specified time limit to:
 - i. sign the Agreement; or
 - ii. Furnish the required Performance Guarantee or
 - iii. If the bidder fails to convince the Employer about the reasonability of his bid prices in the case of an unbalanced bid.
- d) In such cases the work shall be rearranged at the risk and cost of the selected bidder.

(C) REFUND OF THE EARNEST MONEY DEPOSIT TO UNSUCCESSFUL TENDERER

The earnest money deposit of the unsuccessful tenderers shall be refunded after the tenders are disposed of.

(D) CONVERSION OF EMD INTO SECURITY

The EMD submitted by the tenderer cannot be converted to form part of the security deposit required to be presented by the tenderer for executing agreement on award of work.

8.12 INITIAL SECURITY DEPOSIT AND RETENTION AMOUNTS (Amended)

The successful bidder shall within fifteen days of receipt of Order of Award of Work (Selection Notice), deposit an amount equivalent to 3% of the accepted contract value at least 50% of the deposit shall be submitted in the form of Treasury Fixed Deposit and the rest in the form of Bank FD in favour of the Regional Project Director - KRWSA, RPMU ,Kannur as stated in clause 7.21 (I), Performance Guarantee.

8.12.1 The EMD deposited by the tenderer shall be released as soon as the security amount as above is deposited. Security deposit is the retention amount deducted from the running bill of the contractors

Tenderer

26

Tendering Officer

in addition to the performance guarantee. This will be @ 10% of the gross amount of each running bill so that the amount so retained shall be @ 10% of the value of the work done till then. This can be released only after the completion of the defect liability period of 12 months from the date of work completion. (GO (P)No.7/2021/Fin dated 07.01.2021) .

8.12.2 No exemption shall be allowed for initial security deposit and retention amounts for Govt./ Quasi Govt. undertakings unless there is specific order from government to that effect for this particular work and approved by the authority.

8.13 INTEREST ON SECURITY AND RETENTION (Amended)

8.13.1 No interest shall be payable upon the security deposit, or amounts payable to the contractor under the contract.

8.13.2 The Agency shall have the exclusive right to collect interest on all Govt. Securities or National Savings Certificates endorsed as aforesaid and all interest collected shall be credited to the accounts of the contractors and the contractor shall not be entitled to claim any sum by way of interest or profit on the said securities or National Savings Certificate, save the amount actually collected by the Agency. The interest so collected may either be refunded or adjusted against the contractor's security at the end of each financial year.

8.13.3 The Agency shall not be liable for any depreciation in the value of securities while at its charge nor for any loss of interest thereon.

8.14 REPAYMENT OF SECURITY DEPOSIT (Amended)

8.14.1. As stated in clause 7.21 & 8.12.1

8.14.2. If there is any reduction in the value of the security deposit by reason of any depreciation in the value of Government Securities, the contractor shall within thirty days of such reduction, make good, in cash or in pledgeable securities of National Savings Certificate which shall be suitably endorsed as aforesaid any sum of sums which may have been deducted from or realised from the Sale of his security deposit held in Government securities or any part thereof or from the security deposit held in cash, or any such by which the value of Government Securities has depreciated.

8.14.3 The refund of the security deposit as stated above shall however be, subject to the condition that if such time, where shall remain to be executed by the contractor any work as per the agreement or for the proper functioning of the system ordered during such period, the Agency shall be entitled to withhold payment until the completion of such work, so much of the security deposit as shall in the opinion of the Agreement executing authority, represent the cost of the work so remaining to be executed.

8.14.4. Even when various deductions is made against the bank guarantee it shall be the responsibility of the contractor to attend at his cost, works which are essential to make the scheme functional.

8.15 AMOUNT TO BE QUOTED FOR THE WORK

Tenderers shall quote the amount for the work in the prescribed form BOQ provided in the tender documents and the same shall be furnished electronically. In the tender document the rates quoted by
Tenderer 27 Tendering Officer

the contractor should be exclusive of GST; but inclusive of all taxes, duties, welfare fund, contributions etc. The contractor should indicate separately applicable GST in his tender document.

EMD exemptions.- ~~deleted~~

8.16 PAYMENTS TO THE CONTRACTOR

8.16.1 The procedure for sanctioning and releasing the payment against the contractor's bills is as follows. The contractors are permitted to submit part bills or as final bills on completion of the work awarded. The steps followed for bill preparation is: The **Technical Supervisor** in-charge of the work is responsible for recording the measurements and bill preparation. As part of it measurements are recorded by the **Technical Supervisor** and the same is check measured by the Project Engineer concerned. In addition to this the **Technical Supervisor** prepare the work completion certificate, bill form -23, beneficiaries approved list from the GP, beneficiary list with contribution remittance details, witness certificate from the concerned beneficiaries, and photographs of the unit constructed with any member of the beneficiary family. In addition to this a detailed note by the **Technical Supervisor**, request and GST bill from the contractor has to be collected and submitted to the Manager.

8.16.2 Bills of value less than 10% of the total amount of the contract shall not be presented unless they are of categories. There shall be a minimum period of 30 days between two consecutive bills raised by the contractor. **The maximum number of on account bills including the 90% bill shall be 10 nos.**

8.16.3 Deleted

8.16.4 Bill may be submitted by the contractor as soon as the stage of the work as per the break up for interim payment is completed and Regional Project Director shall take the requisite measures for having the same evaluated and the admissible claim as far shall be allowed.

8.16.5 From the "on account" payment full deduction shall be made for materials if any, issued by the Agency and any other dues from the contractor. The contractor shall furnish along with such bill detailed measurements and specifications of all items involving the use of cement and M S rods or steel to enable the departmental officers to check and admit the issue of the departmental materials.

8.16.6 "On account payments made to the contractor shall be without prejudice to the final making up of the accounts (Except where measurements are specifically noted in the measurement books as final measurement and as such have been signed by the contractor) and shall neither be considered nor used as evidence of any fact stated in or to be inferred from such accounts nor of any particular quantity of work having been executed nor of the manner of its execution being satisfactory.

8.16.7. From the "On account" payments, deductions shall, be made by the Agency at the rate of 1 % of the amount of bill, excluding cost of departmental material if any supplied, towards contribution to the Kerala Construction Workers Welfare Fund Board.

8.16.8 In case of any dispute arising out of the supply of ISI marked pipes before the supply and acceptance by KRWSA, the KRWSA shall be indemnified by the contractor, to the effect that all liabilities shall be borne by the selected contractor and the KRWSA's responsibility shall end with the payment for the measured quantities in accordance with the agreement for the work

8.16.9 Interest for delayed payments: The tenderer/contractor must clearly understand that the settlement of claim either by part bill will be made only according to the availability of budget provision and allotment of funds made with the officer in charge of the work under the respective head of account in which the work is sanctioned and arranged and also subject to the seniority of such bills. No claim for interest or for damages whatsoever shall be made for the belated settlement of claims of bills. No such claims shall be admitted by the Agency.

8.16.10 Any unit is found defective during inspection, such units shall be rejected and payment shall not be released to the contractor.

8.16.11. Checklist before making payment which would ensure quality of pipes and quality of work and workmanship should be adopted and its tracking should be done

8.17. FINAL BILL

8.17.1 The final bill shall be submitted by the contractor within one month of the completion of the work as otherwise the Regional Project Director measurement shall be accepted as final and binding.

8.17.2 Deleted

8.17.3 If any amount which by virtue of this contract, may become due to the contractor be not claimed for payment within three months from the date on which it falls due, the same shall be placed in deposit account and if the amount as placed remains for three years thereafter, the contractor or others to whom it may be legally due shall forfeit the same and it shall be finally credited to Agency.

8.17.4 Deleted

8.17.5 The release of amounts shall not be made if there is litigation with the contractor.

8.18 Deleted

8.19 (A) PAYMENTS WHEN ALTERATIONS ARE INVOLVED

No authorized variation shall vitiate the contract. The Agency shall have the right to make any alteration in the original project proposal/designs during the progress of the work and the Contractor shall be bound to carry them out. The amount agreed to for the work shall be varied by adding to or deducting there from as the case may be, the value of all authorized alterations, additions, or omissions, the valuation being made on the same basis as for the extra items.

8.19 (B) Variation in quantity: The Employer/Engineer-in charge reserves the right to vary the quantities of items or groups of items to be ordered as specified in the Bill of quantities, as may be necessary, during the execution of the Contract. The Contractor is bound to execute such varied quantities of work at his quoted price up to an extent of 25% in excess of the agreed quantity or quantities. If there is necessity of executing a specific item or items of work than 25% in excess of the agreed quantity, the contractor may claim excess rate and the Technical Sanction Authority shall finalise such excess rate upon the recommendations of the Engineer-in-charge. Such rates shall not exceed the rates worked out based on approved local market rates prevailing at the time of execution of the excess quantity plus contractors profit and overheads including VAT and expenses towards first tier quality test, if any required on account of the excess quantity beyond the 25%. The data adopted while preparing the original estimate shall be used for preparing the rate for the excess quantity also. Tender variation will not be allowed over this rate. The rate thus arrived shall only applicable for the excess quantity beyond 25% of the original quantity. If any delay occurred on account of approval of rate for such excess quantity, such delay shall not be considered for any time extension and does not relieve the contractor from his obligation of executing excess quantity than 25% in excess of the original quantity

ordered within the stipulated time period of completion.

EXTRA ITEM

If the rates for the extra, additional, altered or substituted items of work are not specifically provided in the Contract Schedule of Rates then such rates shall be derived from the similar items in the Standard Data Analysis published by the Central Public Works Department with relevant cost indices as applicable. If, market rate of a specific item/items are taken for the rate analysis, then provision for cost escalation for such items shall not be allowed. The Engineer's interpretation as to what is a similar class of work and his decision on the method in which the rate is to be derived shall be final and binding on the Contractor.

If the rates for the extra, additional, altered or substituted items of work cannot be determined in the manner specified above, then the rates for such work shall be determined on the basis of actual /theoretical consumption of materials, and actual /theoretical use of labour, as detailed below; consideration of actual or theoretical consumption shall be at sole discretion of the Engineer-in-Charge.

- a. Cost of materials actually used by the Contractor and /or by theoretical analysis of consumption of materials at work, at no more than prevailing local market rates, actually incorporated in the Work/ or as published by the Executive Engineer, Buildings Division of the concerned District from time to time.
- b. Cost of labour actually used at the Site and /or by theoretical analysis of labour utilization on the Work at no more than prevailing local market rates, actually incorporated in the Work/ or as published by the Executive Engineer, Buildings Division of the concerned District.
- c. 1% of the costs in respect of (a) and (b) above, towards water charges, can be added, if required as per the discretion of the Engineer-in -charge.
- d. 15% of the costs in respect of (a), (b) and (c) above, towards Contractor's establishment, electricity charges, tool & plants, all other costs, overhead & profit plus applicable VAT/WCT shall be added. Said 15% component (Contractor's overheads and profit) shall not be allowed on Employer supplied items, Bitumen if any.
- e. For this purpose the Contractor shall submit to the Engineer-in- Charge detailed analysis of the rate proposed by him supported by relevant vouchers along with the estimated quantity of work item involved.

If the Contractor and the Engineer-in-Charge cannot agree on a rate as determined in accordance with this sub-clause, then the Engineer-in-Charge may determine a reasonable rate with the concurrence of the Employer and the Employer which shall be final and binding on the Contractor or, at the Employers /Engineer-in-Charge's option, may order and direct the work to be carried out by such other persons or agencies as it may think fit, and such other persons or agencies shall not, in any manner be prevented or obstructed in their work or from entering upon the Work by the Contractor for the purpose of carrying out such work. The Contractor shall not be entitled to any payment whatsoever in connection with such work carried out by such other persons or agencies.

Before any extra work is undertaken by the Contractor, he shall ensure that he has received from the Engineer-in-Charge a specific Change Order on a mutually agreed proforma, signed and approved by the Engineer-in-Charge. No additional payments shall be made to the Contractor without prior agreement and receipt of the necessary signed Change Order. Each Change Order shall clearly state the value of the additional work agreed to and signed for by the Engineer-in-Charge. The Contractor shall

at monthly intervals submit to the Engineer-in-Charge an account giving particulars, as full and detailed as possible, of additional work ordered in writing by the Engineer-in-Charge and which the Contractor has executed during the preceding month. In case any Change Order instructed by the Engineer-in-Charge causes a delay in the completion of the Work causing the Contractor to overrun the time fixed for completion of the Work, the contractor shall notify the Engineer-in-Charge in writing about such expected delay, before /issuance of such change order by the Engineer-in-Charge. If necessary and if requested by the contractor within 3(three) days of the receipt of the change order in writing, the Engineer-in-charge shall organize with due dispatch, a joint review on the question of expected delay, to be held and had amongst the Contractor, Engineer-in-Charge and the Employer and the issue of such expected delay would be immediately resolved through such joint review to facilitate extension of time for completion of the Work. **(Standard bid document for e-tendering)**

8.20. PRICE VARIATION

This contract does not have provision for price escalation under any circumstances except in case of variation in statutory taxes and levies as noted in clause 7.9.3. Even if extension of time of completion has been granted under this contract, under any relevant provision, no escalation in price shall be admissible.

8.21. NO CLAIMS ON ACCOUNT OF FLUCTUATION OF RATES, IDLING OF LABOUR ETC.

8.21.1 No claim shall be entertained on account of fluctuation of rates of labour and materials, railway freight, income tax etc. at any stage.

8.21.2 No claim for idle labour, due to non-supply of materials by the Agency or for any other reason shall be entertained.

8.22. TESTING OF COMPLETED WORK

All tests necessary to ensure that the structure, equipment, pipe lines and fittings which form part of the work, comply with the specifications, shall be carried out at the site at the contractor's cost. If the completed work or any portion thereof is found to be defective before the works executed by the contractor are taken over by the Agency, the Regional Project Director or his authorised person will give the contractor a notice in writing setting forth the particulars of such defects, and the contractor shall forthwith make the defective part, good or replace the same for satisfying the requirements of the contract. Should he fail to do so within the time specified by the Regional Project Director or his authorised person, may make good the defective part or replace the same at the cost of the Contractor and such replacement shall be carried out by the Regional Project Director or his authorised person to the same specifications as in the contract. In the event of contractor refusing to comply with the instructions of the Regional Project Director or his authorised person within the specified period, the contractor is liable to be penalized as per clause 8.10 above.

8.23 GUARANTY PERIOD

8.23.1 The guarantee period shall be 12 months after successful completion.

8.23.2 If it becomes necessary for the contractor to replace or renew any defective portion of the work during the guarantee period. The provision of this clause shall apply to the portion of the work so replaced or renewed, the guaranty period for such work will commence only from the date of completion of such replacement or renewal. The contractor shall rectify the defects notified within a period of seven days from the date of such intimation. If the defects are not remedied within the notified time, the Regional Project Director or his authorised person may proceed to do the work at the contractor's risk and expense, but without prejudice to any

other right, which the Regional Project Director or his authorised person may have against the contractor in respect of such defects. Until the final certificate of having completed the warranty period successfully has been issued, the contractor shall have the right of entry at his own risk and expenses by himself or duly authorized representatives whose names shall have previously been communicated in writing to the Regional Project Director or his authorised person, at all reasonable working hours for the purpose of inspecting the work and taking notes there from and if he desires, at his own risk and expense, making any tests, subject to the approval of the Regional Project Director or his authorised person.

8.23.3 Any defects noticed during the guarantee period shall be properly rectified to the satisfaction of the Agency by the contractor at his own risk and cost.

8.24 Deleted

8.25 EXTENSION OF TIME OF CONTRACT

Time is considered as the essence of this contract. Any delay due to exceptionally adverse climate conditions or other special circumstances of any kind other than default on the part of the contractor shall fairly entitle the contractor for consideration of extension of time of completion for the work without any extra claim. However, such extension shall be at the sole discretion of the employer and without prejudice to the rights of the Agency to terminate the contract treating time as the essence of the contract. The Agency is not bound to take into account any extra ordinary circumstances unless the contractor has submitted full and detailed particulars within 15 days of the incident, which affected the progress of the work. Further, any such extension granted shall not relieve the contractor from the interest on the advance, if any, drawn by him.

8.26. HANDING OVER OF WORK AND CLEARANCE OF SITE

8.26.1 The contractor shall hand over all works executed under the contract to the Beneficiary complete in all respects, and to the satisfaction of the Regional Project Director at the end of satisfactory completion.

8.26.2 The Regional Project Director shall determine the date on which the work shall be regarded as having been completed as contemplated in sub clause above and shall, in support of his determination, grant a certificate to the contractor on an application being so made to him, that the work was duly executed and completed in all respects, on a date to be specified in the certificate and such certificate shall for all purposes be deemed to be the conclusive proof of the date on which the work was so completed. The Regional Project Director shall also from time to time determine the date on which any particular stage of the work shall have been completed and shall, on application, grant a similar certificate to the contractor who shall be bound to follow all such determination in all subsequent dealings with the Agency on the subject matter of the contract in regard to the work.

8.26.3 On completion of the contract, the contractor shall clear away and remove from the site all construction plant, surplus material, rubbish, debris and all temporary works of every kind and leave whole of this' site and work in a neat and clean condition to the satisfaction of the Regional Project Director. No final payment in settlement of the account of the work shall be made to the contractor until, in addition to any other condition necessary for such final payment, the site clearance shall have been effected by him, and in the event of the failure of the contractor to comply with the

Tenderer

32

Tendering Officer

provision of this Sub Clause within 7 days after receipt by' him of a notice to that effect, such clearance may be made by the Regional Project Director at the expense of the contractor and in all such cases the Agency shall not, in any way be liable for any loss or damage to any property of the contractor left at the site caused by such removal, there from and such removal may without prejudice to any other mode of removal be effected by means of public sale of such materials and property or by such other means as may be deemed fit and convenient to the Regional Project Director .

8.26.4 The contractor shall also furnish the following on instructions from the Regional Project Director

- (1) Photographs of different stages of all components and special type of works taken during the course of execution

8.27 SETTLEMENT, ARBITRATION OF DISPUTES AND NON- APPLICABILITY OF ARBITRATION

8.27.1 Settlement of disputes by Arbitration shall not be applicable to this contract.

8.27.2 In the case of any disputes arising between the parties to this contract on any of .the matters covered under this contract, the same shall be settled solely by a competent court having jurisdiction within the State of Kerala, and by no other Court.

KERALA WATER SUPPLY AND SANITATION AGENCY

9. TENDER CONDITIONS: PART-III

CONTRACT CONDITIONS

9.1 LAW GOVERNING THE CONTRACT

9.1.1 All contracts or terms thereof entered into between the Agency and the contractor under these conditions of contract shall be governed and regulated in general by the relevant laws in force in the territory of India relating to contracts.

9.1.2 The contractor shall strictly conform to the provisions, for the time being in force, of any laws relating to works or any regulations and bye-laws made by any local authority or any water and lighting companies or any undertakings within the limits of the jurisdiction of which it is proposed to execute the work or to obtain connection with their systems or undertakings for the purpose of such work, and where the contractor considers that variations in the drawings or specifications of such work are necessary to enable him to comply with the provisions of the law or regulations or bye-laws, as aforesaid, he shall give to the Agreement Executing Agency and the Regional Project Director a notice in writing specifying the variations, and no action in this behalf shall be taken by the contractor until he receives instruction in writing from the Regional Project Director in respect thereof. The Contractor shall be bound to give to the authorities concerned such notices as may be provided in the law, regulations or bye-laws as aforesaid, and to apply all fees and taxes payable to such authorities in respect thereof.

9.2 COMMENCEMENT OF WORK

9.2.1 The contractor shall commence the work within 20 days after the receipt, by him, of an order
Tenderer 33 Tendering Officer

in writing to this effect from the tendering agency and shall proceed with the same with due expedition and without delay, except as may be expressly sanctioned or ordered by the tendering authority or be wholly beyond the contractors' control. If the contractor fails to start work within the time specified by KRWSA after signing the agreement or fails to maintain the specified rate of progress, the security deposit shall be forfeited to KRWSA and the matter will be disposed of suitably by the Agency. If such measure results in any loss to Agency, such loss shall be recovered from the contractor as arrears or revenue but should it be a savings to the Agency, the original contractor shall have no claim whatsoever to the difference. Recoveries on this or any other amount will be made from the sum that is already due or may become due to the contractor on this or any other existing contracts or under the Revenue Recovery Act, or otherwise as the Agency may decide.

9.2.2 It shall be the joint responsibility of KRWSA and the contractor to get appropriate sanction from the related authority.

9.3 OCCUPATION OF LAND

No land belonging to or in possession of the Agency shall be occupied by the contractor without the permission of the Agency. The contractor shall not use or permit to use such land occupied by him for the purpose other than the execution of the works.

9.4 WATER, POWER AND APPROACH ROAD

The contractor shall, at his own cost, make arrangements for obtaining supply of water and power necessary for the work.

9.4.1 The Agency may supply to the contractor part/or whole of the quantity of water required for the execution of the work, from the existing water supply system, if any, near the site of the work if feasible on such, terms and conditions and on such charges as shall be determined by the Agency observing the relevant rules prevailing in KRWSA for such connection and payable by the contractor, provided that the contractor shall at his own expense, arrange to effect the connection and lay additional pipelines to the site.

9.4.2 Notwithstanding the provision contained in Clause 9.4.1, the Agency shall not guarantee the supply of water and no claim for compensation for any failure or short supply of water by the Agency shall be entertained.

9.4.3 The Agency shall render necessary assistance to the contractor for obtaining the power connection, but the expenses for such connections and Electrical Energy charges shall be borne by the contractor.

9.4.4 For testing of pipelines and water retaining structures during the progress of work, the contractor must arrange his own supply of water.

9.4.5 The Agency does not undertake to construct or make available any approach road or other means of approach to the proposed work site and the tenderer shall get acquainted with the available means of approaches to the proposed site and quote for the various items. The Agency shall not be liable for any claim raised later, on the plea of non-availability or non-access to the site..

9.5 TEMPORARY SHEDS AT WORKSITE

9.5.1 Deleted

9.5.2 Deleted

9.5.3 Deleted

9.6 SETTING OUT

9.6.1 The contractor shall be responsible for the true and proper setting out of the works and for the correctness of the position, levels, dimensions and alignments of all parts of the work and for the provision of all necessary instruments, appliances and labour in connection therewith. If at any time during the progress of the work, any error shall appear or arise in the position, levels, dimensions or alignments of any part of the work, the contractor on being required to do so by the Regional Project Director shall at his own expense rectify such error to the satisfaction of the Regional Project Director . The checking up of any setting out or any line or level by the Regional Project Director or his assistant shall not in any way relieve the contractor of his responsibility for the correctness thereof and the contractor shall carefully protect and preserve all bench marks, site and rails, pegs etc. used in setting out the work.

9.6.2 The contractor shall keep at his own cost all portions of work free from water or dampness due to spring, seepage or inclement weather and in a neat and sanitary condition.

9.7. EXECUTION OF WORK

9.7.1 The decision of the Regional Project Director shall be final, conclusive and binding on all questions relating to the meaning of drawings and specifications and to the quality, workmanship and materials used on the work.

9.7.2 The whole of the work shall be executed in perfect conformity with the specifications and drawings of the work approved by the Agency. If the contractor performs work in a manner contrary, to the specifications and drawings or any of them, he shall bear all costs arising or ensuing there from and shall also be liable to the Agency for any loss.

9.7.3 The whole of the work specified and provided for in the contract or that may be necessary to be done in order to form and complete any part thereof shall be executed in the best and most substantial workman like manner with materials of the best and approved quality of their respective kinds, according to the particulars contained in or implied by the specifications and as referred to in any additional particular instructions and drawings as may be found requisite to be given during the execution of the work and to the entire satisfaction of the Regional Project Director .

9.8. WORK DURING NIGHT AND SUNDAYS AND HOLIDAYS

9.8.1 The contractor shall not carry out any work between the hours of sunset and sunrise without the previous permission of the Regional Project Director or his assistant in writing.

9.8.2 No work shall be done on Sundays and holidays without the written permission of the Regional Project Director or his assistant.

9.8.3 However, when work is unavoidable or necessary for the safety of life, property or works, the contractor shall take necessary action forthwith and report to the Regional Project Director immediately.

9.9 FACILITIES OF INSPECTION

9.9.1 The contractor shall afford the Officers of KRWSA every facility for entering in and upon any portion of the work at all hours for inspection or for any other purpose and shall provide all labour, materials, planks, ladders, pumps, appliances and things of every kind required for the purposes aforesaid and the Regional Project Director or his assistant shall at all the times have access, free of cost, to every part of the work and to all places at which materials for the work are stored or being prepared.

9.9.2 The contractor shall give at least seven days" notice in writing to the Regional Project Director and his Assistant whenever any work or materials are intended to be covered up in the earth in bodies or walls or otherwise to be placed beyond the reach of measurements so that the work may be inspected or the correct dimensions thereof may be taken before the work is so covered or placed beyond the reach of measurement and where the contractor defaults to give such notice the same shall at the opinion of the Regional Project Director or his assistant be uncovered and measured at the expenses of the contractor or in the alternative, no payments shall be made for such work or materials.

9.9.3 Should the Regional Project Director or any other Engineer / **Technical Supervisor** authorized in writing by him to supervise the work, at times, consider it necessary for the purpose of enabling him to make any inspection or tests or analysis or to verify or ascertain the quality or strength of any part of the work or of any materials the contractor shall if and when so required to do by the Regional Project Director or the person authorized as aforesaid, open up the work or the materials for inspection or testing or analysis, or pull down, or pull out the work into any number of parts and make such openings into, under or through any part of the work, as may be directed and provide all things which in the opinion of the Regional Project Director or the person authorized as aforesaid, may find necessary to enable the inspection or tests or analysis of the work or any part thereof or of the materials or workmanship to be made and the contractor shall close up, cover, re-build, and make good the whole at his own cost, as and when directed by, and to the satisfaction of the Regional Project Director , provided always that the work, in the opinion of the Regional Project Director is found to be satisfactory and in accordance with the contract, the expenses incurred by the contractor for such examination, inspection or test shall, upon a certificate in this behalf by the Regional Project Director , be borne by the Agency.

9.10 SUSPENSION OF WORK

9.10.1 The contractor shall not suspend any work without the prior written permission of the officer in charge of the work under any circumstances. Any such suspended work shall be treated as incomplete and abandoned by the contractor and the Agency shall have the right to get such works completed through any other manner at the risk and cost of the contractor.

9.10.2 The contractor shall, on an order issued by the Regional Project Director that for any reason the work

shall not be commenced or shall be suspended or stopped before completion, the contractor shall be paid for the work actually done and materials actually supplied up to the date of stoppage but the Agency shall be held in no way responsible for any further liability.

9.11 ALTERATION IN THE WORK TO BE AUTHORISED

9.11.1 No alteration in, or additions to, or omissions from or abandonment of any part of the work shall be deemed to be duly authorized except under written instructions from the Regional Project Director and it shall be the duty of the contractor to obtain in time such written instructions in every case.

9.11.2 If any work over and above that in the contract is required to be executed at the site the contractor shall have no right to be entrusted with the execution of the work and the same may be carried out through another contractor or contractors or by other means at the discretion of the Agency.

9.11.3 The Regional Project Director shall have full powers to send persons upon the premises to execute fittings, other works etc., not included in the contract for whose operations the contractor shall afford every reasonable facility during ordinary working hours, provided that such operations shall be carried out in such a manner as not to impede the progress of the work, included in the contract, but the contractor shall not be responsible for any damage which may happen to or be occasioned by any such fittings or other works, provided that he complies with the Regional Project Director instructions in connection there with and provided that the damage is not caused by himself or his employees. The contractor shall, at all times, co-operate, assist, attend on, and afford facilities for such specialists, as may be employed by Regional Project Director or other works, in connection with the work. The contractor shall also cause such special work or protect it as instructed to avoid injury during progress of the work. For failure, so to protect, the contractor must make good any damage caused. If any part of his work depends for proper execution upon or results from the work of the other contractor, the former shall inspect and promptly report to the Regional Project Director any defect in the work of the latter likely to render it unsuitable for proper execution and results. The failure of the contractor entrusted with the work so to inspect and report shall, for all purposes be deemed to constitute an affirmative approval of the work of the other contractors as being fit and proper for the receipt of his work, except as to defects which may develop in the work of the latter contracts after the execution of his work.

9.12 PRECAUTIONS DURING PROGRESS OF WORK

9.12.1 The contractor shall be responsible to see that the levels, profiles, bench marks, masonry pillars or other marks set up by the Agency for guidance in the execution of the work are not disturbed, removed or destroyed and if any such marks as in the opinion of the Regional Project Director or his assistant, found disturbed, removed or destroyed, they will be replaced by the Agency at the cost of the contractor.

9.12.2 During the execution of the work, the contractor shall at his own cost provide adequate materials for all works relating to shoring, timbering, strutting, scaffolding etc. and execute the same in such a way as to ensure, in abundant measure, the stability and safety of all structures, excavations and works and further ensure that no physical injury or harm is likely to be caused to any person or no damage or loss is caused to any property. When two or more contractors are engaged on work in the same vicinity, they shall work together in a spirit of co-operation and accommodation. The

contractor shall not take or cause to be taken any steps or action that may cause, disruptions, discontent or disturbance to the works, labour and arrangement of other contractors in the neighbouring or other project localities. In case of any difficulties amongst the contractors, the Regional Project Director shall conduct his work so far as it affects the others.

9.12.3 Existing roads or water courses shall not be blocked, cut through, altered, save to the extent permitted by the Regional Project Director . All compensation claimed by the authorities concerned for any unauthorized closure, cutting through, alteration, diversion or obstruction to such roads or water courses by the contractor be deducted from any sums which is due to or may become due to him in terms of the contract, or otherwise according to law.

9.12.4 The contractor shall be responsible for taking all precautions to ensure the safety of the public, whether on the property belonging to the Agency or others and shall post such look-out men, as may in the opinion of the officer in charge, be required to comply with the regulations pertaining to the work.

9.12.5 The contractor shall be responsible for safety arrangement of all equipment used for construction and shall employ trained workmen conversant with the safety regulations. The contractor shall employ only tested equipment and tools for safety and shall periodically repair them to the satisfaction of the Regional Project Director. All test certificates shall be made available to the Regional Project Director or his assistant at the site of the work. If at any time, in the opinion of the Regional Project Director or his assistant, this provision is not complied with the contractor shall forthwith replace equipment and tools.

9.12.6 The contractor shall display notices and arrange for proper fencing at such places where hazardous work is being carried out. The contractor shall provide at his own expense on the work to the satisfaction of the Regional Project Director proper and sufficient firefighting equipment, first aid appliances etc. which shall at all times be available for use.

9.12.7 The contractor shall at all times comply with all rules and regulations made by the Government, local bodies and such directions as may be issued by the Agency from time to time in regard to safety, first aid and health measures. The contractor shall be legally and financially liable for any lapse in taking precaution during execution of works.

9.13. PROCEDURE TO RECTIFY DEFECTIVE WORKS

9.13.1 If it shall appear to the Regional Project Director or his assistant, at any time during the progress of the work or at any time prior to the expiration of the guarantee period of the work, that any work has been executed with unsound, imperfect or unskilled workmanship or with materials of

inferior description, or that any materials or articles provided by the contractor for the execution of the work are unsound or of a quality inferior to that contracted for, or otherwise not in accordance with the contract, the contractor shall, on demanding in writing by the Regional Project Director or his assistant to specify the work, materials or articles, complained of and within the period of time mentioned in the demand, pull down, take up, or take out the work so complained of or objected to, remove from the site or separate from other materials or sort out the materials or articles or part thereof shall have been included any (on account) payment to the contractor, the same shall be taken in to account and deducted from any subsequent payment due

Tenderer

38

Tendering Officer

to the contractor. The contractor shall also remove from the work and site any equipment fixed or otherwise objected to by the Regional Project Director or his assistant or any other persons authorized in writing by him.

9.13.2 The contractor shall forthwith rectify or remove and reconstruct the works so specified either in whole or in part, as the case may require, or as the case may be, and provide proper and suitable materials or articles for material or articles complained of or objected to. If the contractor fail to remedy any defect within the period specified in demand mentioned in sub clause above and in the manner required, or if he shall fail to remove from the site any materials or articles condemned as unsound or otherwise not in accordance with the specifications or to substitute suitable articles for the materials complained of or objected by the Regional Project Director or his assistant may cause such work to be carried out and such materials or other articles to be replaced by such means as he think fit, and all expenses consequent thereon, or incidental thereto, auxiliary thereof, shall be met by the contractor and borne by him and shall be recoverable from him by the Agency or may be deducted by the Regional Project Director from any moneys due or that may thereafter become due to the contractor.

9.13.3 Should the Regional Project Director consider that the work, although not executed in strict accordance with the specifications may be allowed to stand, payment for the same shall be made at such reduced rate as may be fixed but this procedure is quite optional on his part and shall have the concurrence of the Regional Project Director .

9.13.4 In case of quality of work done is found to be poor, contractor will be liable to compensate for cost of rectification/replacement, and shall be blacklisted from participating in future tenders.

9.14 SUPPLY & TESTING OF MATERIALS

9.14.1 The Contractor shall supply all the materials including pump sets, compressors, electrical panel boards, electrical and wiring materials, pipes and specials covered under the contract at his own cost.. Also ISI marked materials should alone be accepted, wherever ISI specifications are available for such item.

9.14.2 Deleted

9.14.3 The contractor shall test or obtain the approved analysis of or weigh all materials required by the specification to be tested or analyzed or weighed where so required by Regional Project Director shall, if any when so required to do, test the whole or each part of the work or the materials in such manner at such times and such place or places, whether before or by the specifications or as may be directed by any of the persons aforesaid.

9.14.4 The contractor shall, if and when so required by the Regional Project Director to do, prepare and / or submit samples of works and materials for the approval of the Regional Project Director such samples shall be retained by the Regional Project Director and no materials which are required to be so tested or analyzed or weighed or of which samples have to be submitted, shall be used in the work, until tests, analysis, weights or samples as the case may be shall have been approved in writing by the Regional Project Director .

9.14.5 All materials for the work must comply with the requirements or specifications laid down in the tender form and must satisfy the tests and / or analysis laid down in the specifications of the Bureau of Indian Standards/International Standards Organization or such other recognized specifications as the Regional Project Director may direct as being equivalent thereto, and in either case with such additional tests and / or analysis as the Regional Project Director may order or in the

absence of such standards or specifications, with such requirements, tests and analysis as in the opinion of the Regional Project Director, are fair and suitable.

9.15 TOOLS AND PLANT SUPPLIED BY AUTHORITY

9.15.1 It shall be the duty of the contractor to provide adequate tools and equipment needed to do the work efficiently and expeditiously. In case any required item of equipment or machinery is available with the Agency the same may be supplied to the contractor on hire at the discretion of the Regional Project Director at the rate fixed by the Regional Project Director and on conditions current in the Agency. The contractor shall bear the running expenses excluding the pay of the Agency staff attached but including cost of restoring the same in good condition at the time of return, due allowance being made for fair wear and tear.

9.15.2 In the event of any departmental material including plant and equipment being made available, the contractor shall arrange for transportation and safe up-keep of the same.

9.15.3 No extension of time will be granted for delay in the procurement of construction equipment and / or spare parts by the contractor.

9.15.4 The contractor shall take responsible care of all tools and plant belonging to the Agency and issue to the contractor for the purpose of the work and shall be liable for any damage or loss caused to the same by him, his agents or his workmen or others whilst the same were in his charge. The contractor shall sign valid receipts for the tools and plant issued to him by the Regional Project Director from time to time and on completion of the work, shall be bound to carry out repairs and shall be liable for any damage done thereto.

9.16 SUBLETTING OF CONTRACT

The contractor shall not at any time assign, sublet his contract or any part thereof to any person or allow such person to become in any way interested therein in any manner what so ever without the prior permission in writing of the Regional Project Director in charge of the work. Any contravention of this condition shall entitle the Agency to rescind the contract and shall also tender the contractor liable for payment to the Agency in respect of any loss or damage arising out of or ensuing from such recession of the contract. Provided further that where the subletting of the work by the contractor, in any case, is permitted' by the Agency, the contractor shall not, at any time, be absolved of any obligation or responsibility under the contract or any part thereof and shall continue to be responsible for all acts or omission and commissions of the sub contract, his agents, servants or workmen as fully and effectually as if the same were acts of omissions and commissions of the contractor, his agents, servants or workmen, as the case may be.

9.17 CONTRACTOR'S AGENT:

9.17.1 The contractor shall, when he is not personally present at the site of the work invariably place and keep at such site a properly qualified agent, duly authorized and empowered to act on his behalf and to receive on his behalf the orders and instructions required or permitted under the contract to be given to the contractor by the Regional Project Director or his subordinates to supervise the work. All such orders and instructions given to, and all acts done by agents shall be binding on the contractor as if such orders and instructions were given to him or, such acts had been done by him.

Tenderer

40

Tendering Officer

9.17.2 Before absenting himself, the contractor shall furnish the name, the designation and the address of the Agent.

9.17.3 Prior to the appointment of such agent, the contractor shall submit to the Regional Project Director the name and other relevant details of the person intended to be appointed as his agent and no appointment shall be made until the Regional Project Director has approved the same and notified his approval in writing to the contractor and whenever the contractor desires to change his agent the same procedure as for the appointment of a new or fresh agent shall be followed.

9.17.4 From the moment the agent so approved and appointed takes charge of the work, he shall be held to be fully authorized and empowered to present and act for and on behalf of the contractor for all or any of the purpose of the contract, and notwithstanding the absence of any formal authority or definite' instructions from the Contractor to the said agent or any defects therein, or the imposition of any restrictions or limitations on the power or authority of such agent by the contractor, nothing whatsoever shall in any way affect, qualify or limit the full authority or power of such agent, or absolve the contractor of his liabilities or obligations under the contract.

9.17.5 The contractor shall forthwith remove from the site and works and not to re-employ without the written permission of Regional Project Director, obtained in his behalf, any agent whose removal the Regional Project Director have asked for in writing, or any assistant whom he may consider incompetent or is sufficiently qualified or to have been guilty of misconduct or negligence and whose removal the Regional Project Director may have asked for in writing.

9.18 SUPERVISORY STAFF OF THE CONTRACTOR

9.18.1 The contractor shall not employ any person who was in the service of the Agency or the Government without definite written sanction of the Agency. The staff employed at the site by the contractor shall be the same as he has agreed for in the relevant format included in this tender document. Any change from the same shall have proper written acceptance of the Regional Project Director .

9.18.2 The contractor shall at all times place and keep on the work an adequate number of efficient and competent staff to give necessary directions to his workmen in the execution of the work and to see that the workmen execute the work in a sound and proper manner and shall employ only such supervisors, workmen and labourers in or about the execution of the work, as are careful and skilled in their various trades and callings.

9.18.3 The contractor shall forthwith remove from the work any supervisor, workmen or labourer objected to by the Regional Project Director , and if and whenever so required by the Regional Project Director the contractor shall submit the correct return showing the name of all staff and workmen employed by him or about the work.

9.18.4 If, in the opinion of the Regional Project Director, the contractor is not employing on the work such number of staff and workmen as is reasonably necessary for the proper completion of the work within the time prescribed he shall forthwith communicate his opinion in writing to the contractor, and the contractor shall within seven days of the receipt of the said

communication, employ such additional staff and labour as may be required by the Regional Project Director and any failure on the part of the contractor to comply with such instructions shall entitle the Agency to rescind the contract.

9.18.5 Deleted

9.19 DAMAGES PAYABLE BY THE CONTRACTOR

1. The contractor shall, at his own expenses and to the satisfaction of the Regional Project Director, reinstate and make good or be liable for any compensation for any injury, loss or damage occasioned to any property or right whatsoever, including the property and right of the Agency, servants or employees of the Agency, being injury, loss or damage arising out of or in any way connected with, the execution or purported execution of the contract, and further the contractor shall indemnify the Agency, private person, in respect of any such injury including any injury resulting in death or disability to person or property, including all claims which may arise under the Workmen's Compensation Act, or under any other law for the time being in force or otherwise.

2. The contractor shall (except if and so far as the specifications otherwise provide) indemnify and keep indemnified the Regional Project Director for all losses and claims for injuries or damages to any person or property whatsoever including surface or other damage to land being or crops being on the site suffered by tenants and occupiers which may arise out or in consequence of the construction and maintenance of the works and against all claim, demands, proceedings, damages, costs charges and expense whatsoever in respect thereof or in relation thereto, provided always that nothing therein contained shall be deemed to render the contractor liable for or in respect of or to indemnify the Agency against any compensation or damages for or with respect to

- a. The permanent use or occupation of the land by the work or any part thereof (save in respect of damage to crop as aforesaid).
- b. The right of the Agency to construct the work or any part thereof on, over, under in or throughout the land.
- c. Interference whether temporary or permanent with any right of light, airway or water or other easement or quasi-easement which is the unavoidable result of the construction of the work in accordance with the contract.
- d. Injuries or damages to person or property resulting from any act or neglect done or committed during the currency of contract by the Agency/Departmental officers, servants or other contractors (not being employed by the contractor) or in respect of any claim demand, proceedings, damage, cost, charges and expenses in respect thereof or in relation thereto.

3. If compensation has to be paid to court attachment or judgment etc. due to damage of person or property, such amount will be recovered from the contractor / tenderer.

4. The contractor shall insure all the employees employed in the work site as per rules against any accidents and further claim. KRWSA will not be responsible for any such accidents/claims of employees of the contractor.

9.19.2 METHOD OF RECOVERY

1. Damages payable by the contractor under the terms of the contract may be deducted by the Regional Project Director from part of his security deposit or from any other sums due, or which may become due to him from the Agency or through revenue recovery proceedings.

2. In every case in which under any clause or clauses of this contract, the contractor shall have rendered himself liable to damages amounting to the whole of his security deposit, the Regional Project Director shall have powers to rescind the contract altogether and to have the work completed without further notice, at the contractor's risk or expense as the Agreement Agency/ Regional Project Director may deem best suited to the interest of the Agency and the contractor shall have no claim to compensation for any loss that may accrue from any material he may have collected or engagements he may have entered into, on account of the work and the Regional Project Director shall have powers to deduct whatever amount may be expended on the completion of the work, from any sums that may be due or become due from the Agency the contractor on account of this or any other work or recover such sums from him and his assets, movable and immovable under the provision of the Revenue Recovery Act for the time being in force, as if they were arrears of land Revenue or otherwise as the Agency may choose. And in case the contract shall be rescinded under the provision aforesaid, the contractor shall not be entitled to recover or be paid any sum of any work actually performed under this contract unless and until the Regional Project Director have certified the performance of such work and the value thereof and he shall only be entitled to be paid the value so certified.

3. In the event of the Regional Project Director putting in force the powers vested on him under the preceding clause, he may, if he so requires it, take possession of all tools, plant, materials and stores or any portion thereof, on the place where the works were to be performed or on other land of the Agency adjoining thereto, paying or allowing for the same in account, at the contract rates, or if not specially provided for therein at current market rates, otherwise the contractor may be required to remove such tools, plant and materials or stores from the premises, and in the event of his failing to do so, the Regional Project Director may remove them at the contractor's expense or sell them by auction on account of the contractor. The Regional Project Director may devote all, or such

portion as may be requisite, any guarantee or reserve fund or any moneys due to or become due to the contractor for this or any other work to make good, bad or indifferent work, on the part of the contractor in such manner as he may think desirable.

4. If it shall appear to the Regional Project Director or his subordinate in charge of the work, that any work has been executed with unsound imperfect or unskilled workmanship, or with materials of an inferior description, the contractor shall on demand in writing forthwith rectify, relay, remove or reconstruct the same in whole or in part, as the case may require, at his own cost, and in the event of his refusing to do so within a period to be specified by the Regional Project Director or his subordinate or if he shall fail to remove, from the site of the work within a specified period any material or article which is considered by the same officers as unsound or of bad quality or not agreeable to the terms of the contract and to provide immediately suitable materials or articles in lieu of these condemned, then the contractor shall be liable to pay damages at the rate of one percent on the amount of the estimate for every day not exceeding ten days that he fails to comply with the written demand of the Regional Project Director or his subordinates. And in the event of non-compliance of the written demand even after the lapse of ten days the contract is liable to be terminated at the risk and cost of the contractor without further notice.

5. All compensations or other sums of money payable by the contractor to the Agency under the terms of this contract with the Agency or under any other contract with the Agency, shall without prejudice to any other mode of recovery, be recoverable from the contractor by way of deduction or payment, out of the sale proceed of a sufficient part of the security deposit held in Government Securities or in National Savings Certificate or out of the interest accrued thereon or out of the said security deposit held in cash or out of any sums which may be due or may subsequently become due, to the contractor from the Agency, on any account what so ever and in the event of the value of his security deposit being reduced by reason of any such deductions the shortage shall be made up by effecting extra recovery from subsequent bills or sales.

9.20 RELICS AND EXCAVATED MATERIALS

9.20.1 All gold, silver and other materials of any description and all precious stones, coins, treasures, relics, antiquities and other similar things which shall be found in or upon the site shall be the property of the Government and the contractor shall duly preserve the same to the satisfaction of the Agency and shall, from time to time, deliver the same to such person or persons as the Agency may appoint to receive the same.

9.20.2 The contractor shall not sell, or otherwise dispose of or remove, any sand, stone, clay, ballast, earth, rock or other substances or materials which may be obtained from any excavation made in or upon the site, or any building or produce standing upon the site at the time of obtaining the delivery or possession thereof and all such substances, materials, buildings and produce shall be and shall continue to be the property of the Agency provided that the contractor may, with the permission of the Regional Project Director use the same for the work at such cost as may be determined by the Regional Project Director

9.21 REPORTING OF ACCIDENT

The contractor shall be responsible for the safety of all employees or workmen employed or engaged by him on and in connection with the work and shall forthwith report to **the Director Technical** or his assistant all cases of serious accidents/injuries to any of them, however caused and whatever occurring on the work and shall make adequate arrangements for rendering all possible aids to the victims of the accidents.

9.22 WORKMEN'S COMPENSATION ACT

In every case in which, by virtue of the provisions of Sub Section (1) of Section 12 of the Workmen's Compensation Act 1923, if the Agency is obliged to pay any compensation to a workman employed by the contractor in the execution of the work, Agency shall recover from the contractor the amount of the compensation so paid and, without prejudice to the rights of the employer

under Sub Section(2) of Section12 of the said Act, the Agency shall be at liberty to recover such amount or any part thereof by deducting it from the security deposit or from any sum due from the Agency to the contractor, whether under these conditions or otherwise. The Agency shall not be bound to contest any claim made against him under Sub Section (1) of Section 12 of the said Act except on the written request of the contractor and upon his giving to the Agency full security for all the costs for which the Agency may become liable in consequence of contesting such claim.

9.23 WAGES TO LABOUR

9.23.1 The contractor shall comply with the provisions of the Minimum Wages Act and the rules made there under in respect of all employees or workmen employed or engaged by him on road construction or in building operations or in stone breaking or stone crushing for the purpose of carrying out the contract.

9.23.2 If, in compliance with the terms of the contract, the contractor supplies any labour to be used wholly or partly under the direct orders and control of the Agency whether in connection with the work being executed by the contractor or otherwise for purposes of Agency such labour for the purpose of this clause, be deemed to be persons employed by the contract.

9.23.3 If any money shall, as a result of any claims or applications made under the said Act, be directed to be paid by the Agency, such moneys shall be deemed to be moneys payable to the Agency by the contractor, and on failure of contractor to repay the Agency any moneys as aforesaid within 7 days after the same shall have been demanded, the Agency shall be entitled to recover the same from any money due to the contractor under the contract or any other contract with the Agency.

9.23.4 The Authority shall also be entitled to deduct from any money due to the contractor (whether under the contract or any other contract with the Agency) money paid or payable by the Agency by way of any compensation under the said Act or on account of costs or expenses in connection with any claims thereto and the decision of the Regional Project Director on any question arising out of the application of this clause shall be final and binding upon the contractor.

9.23.5 In respect of all labour directly or indirectly employed, in works for the performance of the contract as part of this agreement, the contractor shall comply with or caused to be complied with all rules framed by the Agency from time to time for the protection of health and sanitary arrangements for the workers employed by the KRWSA and its contractor.

9.24 LABOUR RETURNS

Monthly labour returns shall be submitted by the contractor to the Regional Project Director in the proper forms so as to reach him not later than the first of every month. In addition to the above, the contractor shall also maintain daily and weekly returns of labour employed by him and these shall be made available for verification by the officers of KRWSA as and when called for.

9.25 CONTRACT DOCUMENTS AND MATTERS TO BE TREATED AS CONFIDENTIAL

All documents correspondences, decisions and orders concerning the contract shall be considered as confidential and / or restricted in nature by the contractors and he shall not divulge or allow access to them by any unauthorized person.

9.26 MATERIALS TO BE SUPPLIED BY THE AGENCY

It shall be the responsibility of the contractor to arrange for materials and the Agency shall not issue any material to the contractor.

9.27 CONTRACTOR'S RESPONSIBILITY FOR STORES

The materials such as Cement, MS Rods, tor steel and other materials including pipes and specials required for the work shall be procured by the contractor and the lump sum amount quoted should be inclusive of the cost of cement, steel and all other materials. The cement supplied for use shall be as per ISS 269/1976 and steel as per ISS 1786/1985 with latest amendments, if any.

The materials should bear the relevant ISI/ISO certification marks. Before using any material for the work, the contractor, at his own cost, shall submit to the Regional Project Director for his approval such samples of material as are proposed to be used. The materials shall strictly conform to the specifications approved by the Agency. Notwithstanding anything contained in this clause, the contractor shall be held fully responsible for the quality and soundness of all the materials and machinery that are supplied by him for the execution of the work and completion of the project and the Regional Project Director approval shall not in any way absolve him of his responsibility in this matter. The standard tests as per ISS to ensure the quality of cement, steel and other construction materials shall be got done by the contractor at their cost as per the direction of the officers of KRWSA to ascertain the quality. The Agency reserves the right to super check the results. If the materials supplied are found to be not passing the tests, the same shall be rejected by the Regional Project Director and the contractor shall be bound to dismantle and remove such constructions already made using such substandard quality materials if found during the erection of the work and the contractor shall be fully responsible and liable for such losses to the KRWSA.

9.28 MATERIALS AND PLANT AT WORKSITE

All materials and plants brought by the contractor in or upon the site or on the land occupied by the contractor in connection with the work and intended to be used for the execution thereof shall not be removed from the site of work without the permission of the Regional Project Director.

9.29 GENERAL

All other conditions shall be as in force in the KRWSA, If it is found relevant to explain any clause of this N.I.T. Otherwise the conditions are strictly independent.

Regional Project Director

10. GENERAL TECHNICAL SPECIFICATIONS

10.1 GENERAL

10.1.1 Generally, the specifications of all materials and work pertaining to this contract shall be governed by the relevant Indian Standards and by MDSS. In the absence of Indian Standards, the British Standard Specifications shall be followed. The specifications furnished hereunder are only to enlighten the tenderer on the requirements of KRWSA and are not intended to be against any other specifications stipulated by BIS or other standards and common practices widely adopted in the country at present. In case of a doubt regarding the specifications, the **Technical Supervisor** in charge will clear the doubts and give final decision based on the written request of the contractor. The decisions intimated in writing shall be binding on the contract work.

10.1.2 The successful completion of this contract calls for site surveys, investigation, planning, hydraulic and structural design of the components, assessment of capacity/standard of mechanical, electromechanical and electrical items to be procured, preparation of procurement schedule, preparation of implementation schedule etc. The tenderer shall see that he always sticks on to conservative designs based on time tested and well accepted practices as per the guidelines and norms prescribed by BIS, CPHEEO or such other institutions.

10.1.3. REPORTS, DESIGNS AND DRAWINGS

Deleted

10.1.4 ECO-FRIENDLY SYSTEM OFFER

The system offered and as completed shall be environment friendly and shall not affect / alter the environment beyond any permissible limits stipulated by concerned institutions.

10.1.5 MAN MADE STRUCTURES, OTHER UTILITIES - AFFECTING THE WORK

1 When the works under this contract are executed situations may arise when the works are affected by other man-made structures either in service or abandoned. It is also likely that other utility services installed by various Government bodies are affected by the works under this contract. It shall be the duty of the contractor to ensure whether adequate sanction has been obtained from the agency concerned for the work with the help of KRWSA before the works of such affected portions are undertaken. Any damage caused to any of the manmade structure or any of the utility services will have to be made good by the contractor at his cost. The contractor has to restore the original position if he has to demolish any structure like culverts, compound walls etc during the course of work at his own cost.

10.2 EARTHWORK EXCAVATION

1 Earthwork excavation means earthwork in all classes of soils / rocks whenever removal shall be not by blasting. Earthwork excavation shall be done with adequate care so that underground service lines or adjacent structures are not damaged and appropriate protective

measures such as shoring / strutting / sheet piling etc. are adopted for such items as required and approved by the **Technical Supervisor** in charge of the work. The width of trench should be as per the requirement and as per standard data book and a minimum cover above crown of pipe should be maintained as per clause

10.13. If the width of trench exceeds the minimum requirement as noted above, due to faulty workmanship/ protection/ shoring etc. the additional payment for the extra damaged road width payable to PWD/NH local bodies etc. shall be recovered from the contractor's bill. Excavation by blasting shall be got done only through persons holding valid license for use of explosive material and for blasting purpose. Further all rules prescribed by the Inspectorate of Explosives shall be strictly adhered to whenever blasting is resorted to. Blasted material like the excavated rock shall be the property of KRWSA. Disposal of the materials up to a distance of 10 km from the site as well as cartage of excavated material during excavation and back filling up to a maximum distance of 5.0 km will have to be done whenever essential by the contractor at no extra cost.

10.3 FILLING / BACK FILLING

Filling / back filling shall be done only with approved materials. It shall be compacted to get the following results. The density of the filled materials at different depths shall not be less than 95% of the natural field density in case of back fill and shall not be less than 95% of maximum dry density obtained in proctor compaction test or such other approved tests whenever filling is done to get the desired formation ground level. It shall be ensured that the density thus obtained under compaction is uniform at all depths of the fill. The contractor is bound to bear the cost of any test conducted to ascertain the above condition in case of doubt. The filling/backfilling done along PWD roads or such properties owned by other department/institutions, the same shall be further governed by specifications of such owner.

10.4 SHORING

Shoring shall be essential in excavation in all classes of soils whenever depth of excavation exceeds

1.50m and labourers have to work in trenches or close to edges of trenches as per the direction of **Technical Supervisor** in Charge. In ordinary soils and loose soils, shoring shall be done for trenches of shallower depths also considering the chances of collapse of sides. Shoring shall be done as approved/directed by the **Technical Supervisor** in charge of work.

10.5 FENCING

Fencing shall be done in the approved manner along the side of pipeline trenches on roads or other places for preventing accidents on both sides, if required in the opinion of the **Technical Supervisor in charge**.

10.6 FORMATION OF ROADS

Formation of roads shall be done as per IRC rules and regulations for the use of desired class of vehicles mentioned in the scope of the work. Whenever road formation comes in the scope of the work, it shall be understood that all cross drainage work, side drain works, radius of curvature and super-elevation etc. are included in the scope.

10.7 RUBBLE MASONRY

Rubble masonry works using approved quality blasted rubble either as random rubble masonry or coursed rubble masonry shall be permitted. Minimum width of the random rubble masonry shall not be less than 450mm in any case. Only cement mortar 1:6 or richer shall be used for such works. Mixing by weight at the above ratio for mortar shall be permitted only when the fine aggregate is in dry condition. Exposed surfaces or rubble masonry shall be pointed using 1:3 cement mortar to have a pleasing appearance provided it is left un-plastered with cement mortar.

10.8 BRICK WORK

Brick masonry using wire cut bricks / first class country burned bricks having a minimum crushing strength of 35 Kg / cm² satisfying other tests specified by BIS and least dimensions not less than 70mm alone shall be permitted. Brick masonry works shall be of minimum 200 mm width, constructed in English bond with cement mortar 1: 6 or richer and plastered with cement mortar 1: 4 or richer in all cases. However, in each case of parapets or other dwarf walls of height less than 700 mm, thickness of masonry can be reduced from 200mm provided pilasters of minimum 200 x 200 mm are constructed monolithic with such walls at a center to center spacing of maximum 3000mm.

10.9 PLAIN AND REINFORCED CONCRETE

10.9.1 DESIGN ASSUMPTIONS

IS 3370 Code of Practice for concrete structure for storage of liquids

Part I: (latest edition) General requirements

Part II: (latest edition) Reinforced concrete structures. Part IV: (latest edition) Design tables

IS 2502 (latest edition) Code of practice for bending and fixing of bars for concrete reinforcement.

All RCC/Steel structures shall be based on the relevant IS Codes. Strict adherence must be established to accepted codes of Practice relating to design. Minimum cover to reinforcement for RCC work shall be provided as per IS 456-2000(or latest edition). The effect of seismic forces shall be taken into account in the design as per the relevant code of practice.

10.9.2 CEMENT

The contractor will have to procure the cement for the work. The cement used in the work of plant or water front structures should be sulphate resistant - Portland cement of reputed companies having ISI mark. The KRWSA will have the option of rejecting the cement procured by the contractor and ask for replacements, in case of any doubt on quality and age of cement supplied at site. Random/ grab sampling and test of the cement will be got done by KRWSA.

10.9.3 REINFORCING STEEL

Only Corrosion Resistant Steel (CRS) is to be used for the steel structures. The contractor has to procure all the steel required for the work. The steel so procured should be from reputed companies like SAIL, TISCO etc. and the KRWSA will have the option to select

the brand and to ask for replacement, if the material is found not having adequate quality. The MS/TOR rods supplied for the work shall be cleaned and scrapped to be free of scales rust etc., before placing in forms for R.C.C work.

10.9.4 AGGREGATES

The coarse and fine aggregates shall comply with IS 388-1980 or latest edition and may be used after sufficient tests have been carried out and approved by the Regional Project Director . All aggregates shall be stored on hard impervious surface to ensure exclusion of all foreign materials.

10.9.5 WATER

The water for mix shall be clean and free from harmful matter as per IS standards and taken from a source approved by the Regional Project Director.

10.9.6 ADMIXTURES

Only where a beneficial effect is produced shall any admixture to be used and that too after tests have been carried out to convince Regional Project Director that no harmful effect will be produced by the use of such admixture and after approved by the Regional Project Director . Time tested admixtures shall be permitted to be used for concrete based on testimonial of performance to improve the quality of concrete with respect to its strength, water tightness or for other specified purposes as required for the work.

10.9.7 MIXING

The grade of concrete shall be as per IS 456 or its latest revision. All water retaining or water front structures and machine foundations shall be made using RCC mixes as per relevant codes. The mixing time shall be between 2 to 4 minutes. The contractor should produce mix design for all grades of concrete to be used for the work and get approval from the Regional Project Director before commencement of concreting.

10.9.8 CONCRETING

The concrete mix shall be in specified proportions satisfying the maximum aggregate size/water cement ratio and required cube strength and workability. Such concrete must be adequately vibrated to form solid mass without voids. External vibration by the use of pneumatic hammers shall be deemed adequate except for thin sections.

10.9.9 TRANSPORTATION AND PLACING

Transportation and deposition of concrete mix shall be done rapidly and accurately with minimum re- handling. The mix must not be dropped from such a height as may cause segregation and air entrapment. When the mix is placed in position, no further water shall be added to provide easier workability. No concrete mix shall be used for the work if it has been left for a period exceeding its initial setting time before deposited and vibrated into its final position in the member. Sufficient number of cubes must be made for testing as per the relevant BIS code specifications. It shall be tested as per the specification and a complete register of entries shall be maintained by the contractor. It shall be brought to the notice of the **Technical Supervisor** in charge as and when directed by the departmental officer. The cost of all such testing shall be borne by the contractor.

10.9.10 CONSTRUCTION JOINTS

Construction joints shall be avoided wherever possible, and if found necessary, should be of such form to encounter direct compression. A stepped joint being preferred in such a case.

10.9.11 CURING

Curing shall be done as per relevant provisions in the IS code to allow the concrete attain strength through normal hydration and to avoid excessive shrinkage or harmful effect to the member. The method adopted shall be effective and any special method used must be approved by the Regional Project Director.

10.9.12 REMOVAL OF FORM WORK

Removal of form work shall be done as per the provisions in the BIS and as per direction of the Regional Project Director and in such a manner that no damage is caused to the deflection to minimum deflection, when unsupported and as per the direction of the Regional Project Director.

10.10 DOORS, WINDOWS AND VENTILATORS

10.10.1 deleted

10.10.2 deleted

10.10.3 deleted

10.10.4 deleted

10.11 PLASTERING OF EXPOSED SURFACES

All exposed concrete surfaces shall be plastered with cement mortar 1:4 or richer mixes. Exposed surface means exposed to air or water or any other gaseous or liquid medium. Surfaces of concrete structures other than water retaining structures can be permitted to be left unplastered under the following conditions:

- (i) The surface left unplastered is perfectly even without markings of formwork or undulations or unevenness greater than 0.5 mm.
- (ii) The surface texture is perfectly uniform and the appearance is pleasing.

10.12 TESTING OF WATER RETAINING STRUCTURES.

All Ferro cement tanks shall be filled with water and tested for water tightness before finishing.

10.13 PIPES AND PIPE LAYING deleted

10.14 NON DESTRUCTIVE TEST FOR STRENGTH:

Any constructed structure or erected equipment shall be subject to a non-destructive test to ensure or certify about its capacity to yield the desired service if required by the **Technical Supervisor** in charge. Such tests shall be the ones specified by the ISS / BSS / CPHEEO Manuals or a more severe test. An equipment / component shall be deemed to have satisfactorily passed such a test only if the **Technical Supervisor** in Charge of the works is satisfied on the performance under test conditions.

10.14 Deleted

10.15 The G.P. approved list of beneficiaries (Residential buildings) shall be made available by KRWSA, and the location/Position of the RWH unit in the premises shall be fixed jointly by House Owner, **Technical Supervisor** and the Contractor.

10.16 The construction should be in accordance with the attached drawing and in conformity with IS 13356 (1992) roof top rainwater harvesting guide lines & IS 15797(2008) Precast Ferro cement water tanks up to 10000 litres capacity and its amendments.

10.17 TRAINING TO AGENCY STAFF

The **Technical Supervisor** in charge will furnish a list containing the names and designations of the various staff to whom the training in the operation, maintenance and attending to emergent situations are to be given. When the contractor is satisfied that sufficient training both in theoretical and practical aspects have been imparted to the staff thus deputed, shall issue a certificate in that respect which shall be forwarded to the **Technical Supervisor** in Charge. The training shall preferably be in the place of the project work. However, if requested, the contractor shall be permitted to give part of the training to the Agency staff at his place of choice after due consideration of all aspects.

10.18 If any of the conditions above are in contradiction to any of the clauses in the scope of Work, the clause/conditions of the Scope of Work shall prevail .

10.19 Contractors/Firms shall not appoint/employ directly/indirectly the retired employees of KRWSA within 3 years of their retirement/Voluntary retirement

11. SPECIAL CONDITIONS

11.1 Billing of partially completed RWH units will not be permitted.

11.2 Where ever scarcity of Rubble is commonly felt, the basement of RWH is permitted to be constructed with P: C: C 1:3:6 with 40 mm and 20 mm broken stone in the ratio 1:1 in the same dimensions without any additional financial commitment.

11.3 In the tender document the rates quoted by the contractor should be exclusive of GST; but inclusive of all taxes, duties, welfare fund, contributions etc. The contractor should indicate separately applicable GST in percentage in tender document (BoQ).

Contractor

Regional Project Director.

KERALA RURAL WATER SUPPLY AND SANITATION AGENCY

Name of Work: Name of Work:-

Construction of 138Nos. open well recharge and 12Nos. Homestead open wells into Protected, Sanitized wells diameter up to 2m and upto 6m with recharge pit , under State Plan Scheme 2021-22, Alakode GP, Kannur District.

**NOTICE INVITING TENDER (SCOPE OF
WORK & BILL OF QUANTITIES)
VOLUME – 2**

Tender No : **111/KRWSA/KNR/DWS&R/ALKD/2022-23**
Tendered PAC : **Rs.35,85,952/-**
Last date of online submission of tenders : **18/05/2023, 06.00 PM**
Date of tender opening : **20/05/2023, 11.00 AM**

**OFFICE OF THE REGIONAL PROJECT DIRECTOR
KRWSA.
REGIONAL PROJECT MANGEMENT UNIT, KANNUR**

**KERALA RURAL WATER SUPPLY AND SANITATION
AGENCY**

A. SCOPE OF WORK

Name of Work: Name of Work: Construction of 138Nos. open well recharge and 12Nos. Homestead open wells into Protected ,Sanitized wells diamter up to 2m and upto 6m with recharge pit , under State Plan Scheme 2021-22, Alakode GP, Kannur District as per the list approved by GP

1. GENERAL INFORMATION

This project is to implement the construction of 138Nos. open well recharge and 12Nos. Homestead open wells into Protected ,Sanitized wells diamter up to 2m and upto 6m with recharge pit, under State Plan Scheme 2021-22, Alakode GP, Kannur District. The list of selected beneficiaries will be approved in the meeting of Grama Panchayath Board and signed by the Secretary of Alakode Grama Panchayath, Kannur district

The approved beneficiaries Alakode Grama Panchayath, Kannur district list shall be made available to the contractor by KRWSA, and the location/Position for the construction of 138Nos. open well recharge and 12Nos. Homestead open wells into Protected, Sanitized wells diameter up to 2m and upto 6m with recharge pit in the premises of beneficiaries shall be finalised jointly by the house owner and Technical Supervisor in Charge.

2. CONCISE SCOPE OF WORK

The scope of work includes Construction of 138Nos. open well recharge and 12Nos. Homestead open wells into Protected, Sanitized wells diameter up to 2m and upto 6m with recharge pit , under State Plan Scheme 2021-22, Alakode GP, including all plumbing works to enable to collect the roof top rain water and the over flow to suitable recharge arrangement.

3. Land for structures

The location / site for the construction of the 15 WELLS CONVERSION OF HOMESTEAD WELL INTO PROTECT SUSTAINABLE DRINKING WATER SOURCE and 159 Well recharge with allied activities in the premises of beneficiaries (residential building) will be provided by respective beneficiaries as per the list approved by ALAKODE Grama Panchayath, Kannur district.

- 3. General technical specification** Earth work in excavation by mechanical means (Hydraulic excavator)/manual means over areas (exceeding 30 cm in depth, 1.5 m in width as well as 10 sqm on plan) including disposal of excavated earth, lead up to 50 m and lift up to 1.5 m, disposed earth to be levelled and neatly dressed. All kinds of soil supply and fixing of gutter pipe with 160 mm PVC 6kg/cm² at the edge of the sloped roof including all clamping/ welding clamps for holding the gutter pipes in the position etc including cost of all specials, end closures, tees and labour charges etc complete.
 Supplying & fixing first flush valve - 75 mm PVC valve including cost of tee, bend etc: Supply and Fixing 63 mm PVC 6kg/cm² for down pipe from recharge pit (inside the well) Supply and Fixing 75 mm PVC 6kg/cm² down pipe: Providing and laying in position cement concrete of specified grade excluding the cost of centering and shuttering - All work up to plinth level:1:3:6 (1 cement : 3 coarse sand : 6 graded stone aggregate 20 mm nominal size) Supplying, seiving, stacking and spreading 40mm broken stone in the gallery trenches as per standard norms including cost of all materials. Supplying, seiving, stacking and spreading 20mm to 12.5mm broken stone in the gallery trenches as per standard norms including cost of all materials Supplying, seiving, stacking and spreading 10mm to 6mm broken stone in the gallery trenches as per standard norms including cost of all materials Supplying, seiving, stacking and spreading 10mm to 6mm broken stone in the gallery trenches as per standard norms including cost of all materials

Providing and laying in position cement concrete of specified grade excluding the cost of centering and shuttering - All work up to plinth level:1:4:8 (1 cement : 4 coarse sand : 8 graded stone aggregate 40 nominal size Reinforced cement concrete work in well-staining excluding the cost of centering, shuttering, finishing and reinforcement, with 1:1. 5:3 (1 cement : 1.5 coarse sand : 3 graded stone aggregate 20 mm nominal size) : 12 mm cement plaster of mix:1:4 (1 cement : 4 fine sand) Finishing walls with water proofing cement paint of required shade:New work (Two or more coats applied @ 3.84 kg/10 sqm)

The type design will be provided by KRWSA. It comprises of following components.

5. Pre Operation and Maintenance before commissioning

1. Before collecting water , the roof and gutters should be cleaned
2. Keep the well and surroundings clean and hygiene.
3. Ensure cover of filter chamber properly placed.
4. Ensure that the water flow is channelled to the well.
5. The filter media is cleaned and replaced periodically.
6. Ensure to sustain the source to provide potable drinking water.
7. The source converted to a Functional Household tap Connection (FHTC).

B. **BILL OF QUANTITIES (BOO)**

Sl. No.	Item Description	Quantity	Units
1	2	4	5
1	WELL RECHARGING		
1.01	SUPPLYING AND FIXING PLUMBING SYSTEMS		
1.02	od209795/2022_2023 : Supply and fixing of gutter pipe with 160 mm PVC 6kg/cm ² at the edge of the sloped roof including all clamping/ welding clamps for holding the gutter pipes in the position etc including cost of all specials, end closures, tees and labour charges etc complete.
	1788.0000	metre
1.03	od183951/2022_2023 : Supplying & fixing first flush valve - 75 mm PVC valve including cost of tee, bend etc	138.0000	each
1.04	od183963/2022_2023 : Supply and Fixing 63 mm PVC 6kg/cm ² for down pipe from recharge pit (inside the well)	1438.9500	metre
1.05	od183964/2022_2023 : Supply and Fixing 75 mm PVC 6kg/cm ² down pipe from the gutter pipe already fixed in position up to the filter pit and from filter pit to well including all clamping/ welding clamps for holding the down pipes in the position etc including cost of all specials, end closures, tees and labour charges etc complete.	2422.7000	metre
2	INSTALLATION OF RECHARGE PIT (FERROCEMENT CHAMBER)		
2.01	2.6.1 : Earth work in excavation by mechanical means (Hydraulic excavator)/manual means over areas (exceeding 30 cm in depth, 1.5 m in width as well as 10 sqm on plan) including disposal of excavated earth, lead up to 50 m and lift up to 1.5 m, disposed earth to be levelled and neatly dressed.All kinds of soil	6.7886	cum
2.02	4.1.5 : Providing and laying in position cement concrete of specified grade excluding the cost of centering and shuttering - All work up to plinth level:1:3:6 (1 cement : 3 coarse sand : 6 graded stone aggregate 20 mm nominal size)	6.7886	cum
2.03	100.41.35 : Supplying, seiving, stacking and spreading 40mm broken stone in the gallery trenches as per standard norms including cost of all materials.	7.8731	cum
2.04	100.41.36 : Supplying, seiving, stacking and spreading 20mm to 12.5mm broken stone in the gallery trenches as per standard norms including cost of all materials.	8.0331	cum

2.05	100.41.37 : Supplying, seiving, stacking and spreading 10mm to 6mm broken stone in the gallery trenches as per standard norms including cost of all materials.	4.0166	cum
2.06	od183919/2022_2023 : Supplying and filling coconut shell (burnt shell)	158.4100	each
2.07	od199144/2022_2023 : Supplying and fixing 60cm inner dia & 75cm height ferro cement filter media chamber with cover slab and suitably fix it over the concrete slab and filling with filter media as per the attached drawing etc complete.	138.0000	each
3	CONVERSION OF HOMESTEAD WELL INTO PROTECT SUSTAINABLE DRINKING WATER SOURCE		
3.01	Well protection work		
3.02	100.3.3.1 : Earthwork open well excavation (above water) for wells of dia. above 2.5m and upto 3.50 m in all kinds of soil and conveying and depositing the spoil within initial lead of 50m and lift up to 1.5 m including neat banking. NEW DATA (Prepared based on PHED SDB - Item No.1080 & 1083	43.8000	cum
3.03	4.1.8 : Providing and laying in position cement concrete of specified grade excluding the cost of centering and shuttering - All work up to plinth level:1:4:8 (1 cement : 4 coarse sand : 8 graded stone aggregate 40 nominal size)	12.9630	cum
3.04	50.5.7 : Reinforced cement concrete work in well-staining excluding the cost of centering, shuttering, finishing and reinforcement, with 1:1. 5:3 (1 cement : 1.5 coarse sand : 3 graded stone aggregate 20 mm nominal size)	34.9580	cum
3.05	5.9.12 : Centering and shuttering including strutting, etc. and removal of form for:Well steining	462.8000	sqm
3.06	5.22.1 : Steel reinforcement for R.C.C work including straightening, cutting, bending, placing in position and binding all complete upto plinth levelMild steel and Medium Tensile steel bars	2327.1800	kg
3.07	13.1.1 : 12 mm cement plaster of mix:1:4 (1 cement : 4 fine sand)	211.4300	sqm
3.08	18.12.5 : Providing and fixing G.I. pipes complete with G.I fittings including trenching and refilling etc. External work40 mm dia nominal bore	44.4700	metre
3.09	13.44.1 : Finishing walls with water proofing cement paint of required shade:New work (Two or more coats applied @ 3.84 kg/10 sqm)	211.4300	sqm
3.1	13.37.1 : White washing with lime to give an even shade:New work (three or more coats)	260.0600	sqm

3.11	13.46.1 : Finishing walls with Acrylic Smooth exterior paint of required shade:New work (Two or more coat applied @ 1.67 ltr/10 sqm over and including priming coat of exterior primer applied @ 2.20 kg/10 sqm)	211.4300	sqm
3.12	Welding 40mm gi pipe	12.0000	each
4	Well Recharging-Supplying and Fixing Plumbing system		
4.01	od234062/2022_2023 : Supply and fixing of gutter pipe with 160 mm PVC 6kg/cm2 at the edge of the sloped roof including all clamping/ welding clamps for holding the gutter pipes in the position etc including cost of all specials, end closures, tees and labour charges etc complete.	121.7000	metre
4.02	od234063/2022_2023 : Supply and Fixing 75 mm PVC 6kg/cm2 down pipe from the gutter pipe already fixed in position up to the filter pit and from filter pit to well including all clamping/ welding clamps for holding the down pipes in the position etc including cost of all specials, end closures, tees and labour charges etc complete.	178.6000	metre
4.03	od234064/2022_2023 : Supplying & fixing first flush valve - 75 mm PVC valve including cost of tee, bend etc	27.0000	each
4.04	od234065/2022_2023 : Supply and Fixing 63 mm PVC 6kg/cm2 for down pipe from recharge pit (inside the well)	72.4000	metre
5	Installation of Recharge pit (Ferrocement Tank)		
5.01	4.1.5 : Providing and laying in position cement concrete of specified grade excluding the cost of centering and shuttering - All work up to plinth level:1:3:6 (1 cement : 3 coarse sand : 6 graded stone aggregate 20 mm nominal size)	0.5869	cum
5.02	100.41.35 : Supplying, seiving, stacking and spreading 40mm broken stone in the gallery trenches as per standard norms including cost of all materials.	0.6805	cum
5.03	100.41.36 : Supplying, seiving, stacking and spreading 20mm to 12.5mm broken stone in the gallery trenches as per standard norms including cost of all materials.	0.7005	cum
5.04	od234066/2022_2023 : Supplying and filling coconut shell (burnt shell)	14.9150	each
5.05	od234067/2022_2023 : Supplying and fixing 60cm inner dia & 75cm height ferro cement filter media chamber with cover slab and suitably fix it over the concrete slab and filling with filter media as per the attached drawing etc complete.	12.0000	each
5.06	100.41.37 : Supplying, seiving, stacking and spreading 10mm to 6mm broken stone in the gallery trenches as per standard norms including cost of all materials.	0.3453	cum

5.07	od209795/2022_2023 : Replacing Supply and fixing of gutter pipe with 160 mm PVC 6kg/cm2 at the edge of the sloped roof including all clamping/ welding clamps for holding the gutter pipes in the position etc including cost of all specials, end closures, tees and labour charges etc complete.
	148.3000	meter
5.08	od183951/2022_2023 : Replacing Supplying & fixing first flush valve - 75 mm PVC valve including cost of tee, bend etc	24.0000	each

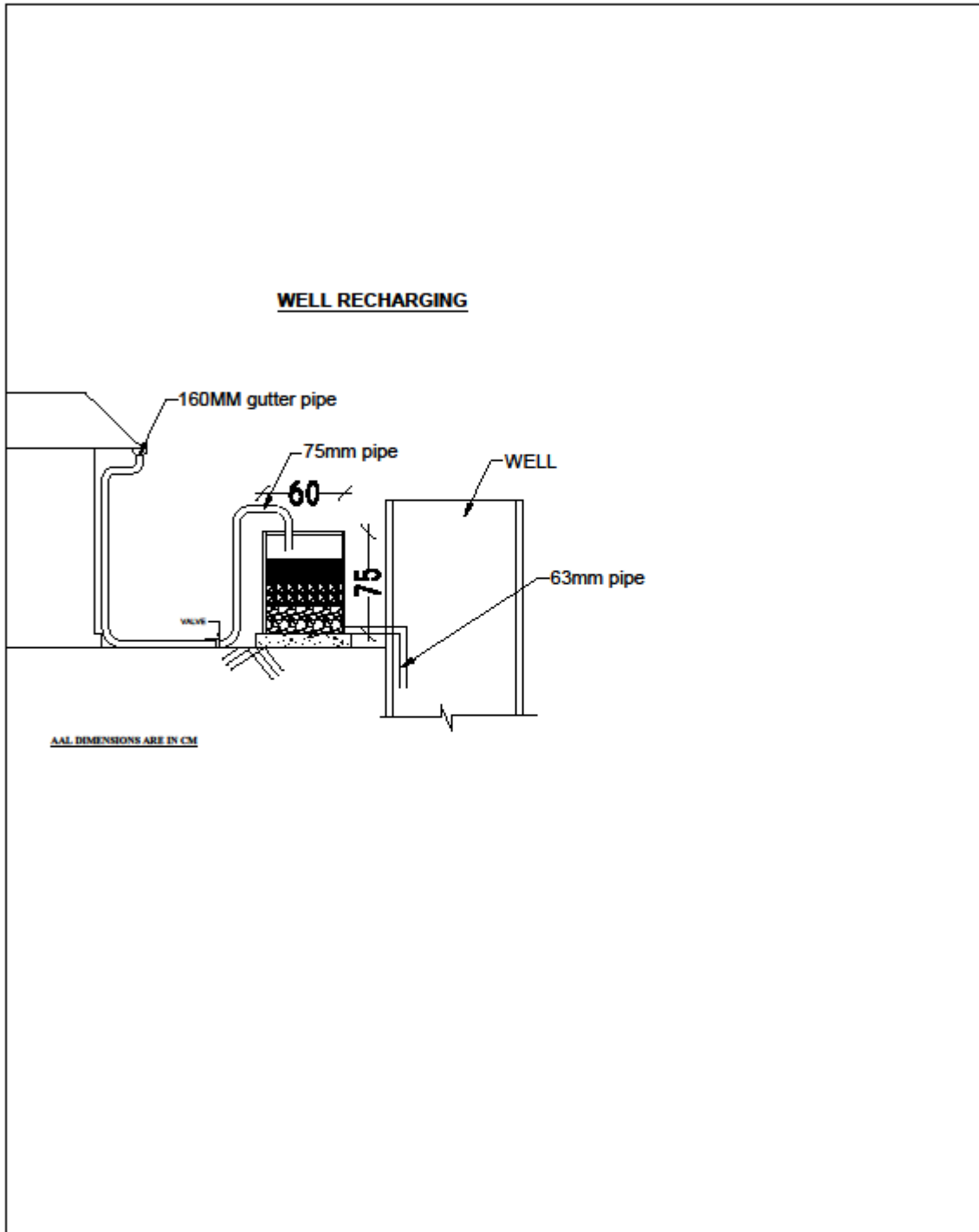

DOMESTIC WELL SANITIZATION

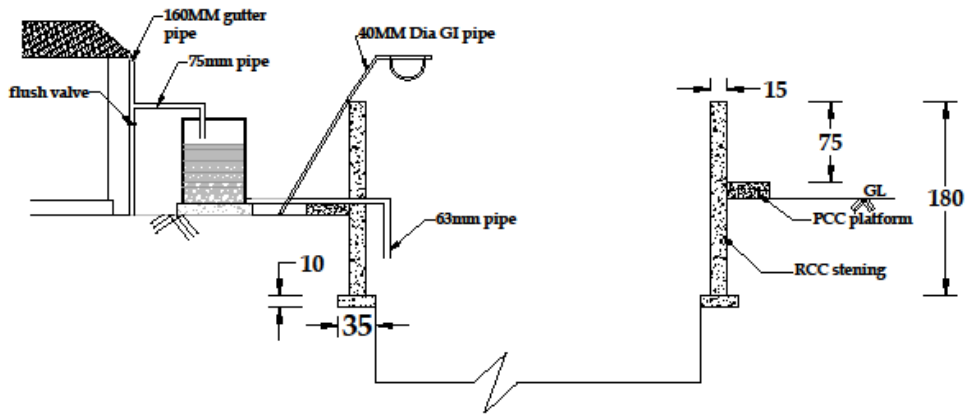

SCALE : 1:100
ALL DIMENSIONS ARE IN CM